



ORIGINAL INSTRUCTIONS



Refer to Declaration of Conformity for relevant Directives

Instruction Manual
5 port Solenoid Valve

Series SY3000/5000/7000/9000 Type 20/40/60

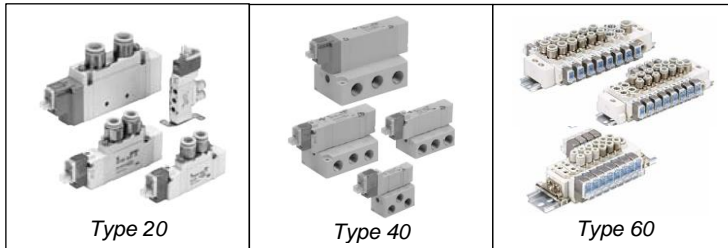

The intended use of this valve is to control the movement of an actuator.

1 Safety Instructions

These safety instructions are intended to prevent hazardous situations and/or equipment damage. These instructions indicate the level of potential hazard with the labels of "Caution," "Warning" or "Danger." They are all important notes for safety and must be followed in addition to International Standards (ISO/IEC¹⁾, and other safety regulations.
¹⁾ ISO 4414: Pneumatic fluid power - General rules relating to systems.
 ISO 4413: Hydraulic fluid power - General rules relating to systems.
 IEC 60204-1: Safety of machinery - Electrical equipment of machines. (Part 1: General requirements)
 ISO 10218-1: Manipulating industrial robots -Safety, etc.

- Refer to product catalogue, Operation Manual and Handling Precautions for SMC Products for additional information.
- Keep this manual in a safe place for future reference.

	Caution	Caution indicates a hazard with a low level of risk which, if not avoided, could result in minor or moderate injury.
	Warning	Warning indicates a hazard with a medium level of risk which, if not avoided, could result in death or serious injury.
	Danger	Danger indicates a hazard with a high level of risk which, if not avoided, will result in death or serious injury.

Warning

- Always ensure compliance with relevant safety laws and standards.
- All work must be carried out in a safe manner by a qualified person in compliance with applicable national regulations.

2 Specifications

2.1 Valve Specifications

Series	SY3000	SY5000	SY7000	SY9000*
Fluid	Air			
Internal pilot operating pressure range (MPa)	2 position single	0.15 to 0.7		
	2 position double	0.1 to 0.7		
External pilot Operating pressure range (MPa)	3 position	0.2 to 0.7		
	Operating pressure range	-100 kPa to 0.7		
Pilot pressure range (MPa)	2 position single/double	0.25 to 0.7		
	3 position	0.25 to 0.7		
Ambient and fluid temperature (°C)	-10 to 50 (no freezing)			
Max. operating frequency (Hz)	2 position single/double	10	5	5
	3 position	3	3	3
Min. operating frequency	1 cycle / 30 days			
Manual override (Manual operation)	Non-locking push type, Push-turn locking slotted type, Push turn locking lever type			
Pilot exhaust method	Common exhaust type for main and pilot valve			
Flow rate	Refer to catalogue			
Response time	Refer to catalogue			
Duty cycle	Contact SMC			
Lubrication	Not required ^{Note 1)}			

2 Specifications – continued

Mounting orientation	Unrestricted
Impact/Vibration resistance (m/s ²)	150/30 ^{Note 2)}
Enclosure	Dust proof (DIN terminal and M8 connector: IP65 ^{Note 3)})

Table 1

- *SY9000 only available for Type 20 and 40.
- Note 1) If lubrication is used in the system, use class 1 turbine oil (no additive), ISO VG32
- Note 2) **Impact resistance:** No malfunction occurred when tested in the axial direction and at the right angles to the main valve and armature in both energized and de-energized states every time for each condition. (Values at the initial period)
Vibration resistance: No malfunction occurred in a one-sweep test between 45 and 2000 Hz. Test was performed at both energized and de-energized states in the axial direction and at the right angles to the main valve and armature. (Values at the initial period)
- Note 3) Based on IEC60529

2.2 Solenoid Specifications

Electrical entry	Grommet (G), (H) DIN terminal (D), (Y) L plug connector (L) M plug connector (M) M8 connector (W), (WA)			
			G, H, L, M, W, WA	D, Y
Coil rated voltage (V)	DC	24, 12, 6, 5, 3		24, 12
	AC 50/60 Hz	100, 110, 200, 220		
Allowable voltage fluctuation		±10% of rated voltage ^{Note 1,2)}		
Power consumption (W) - DC	Standard	0.35 (With indicator light: 0.4 DIN terminal with indicator light: 0.45)		
	With power saving circuit	0.1 (With indicator light only) ^{Note 3)} [Starting 0.4, Holding 0.1]		
Apparent power (VA) ^{Note 3)} - AC	100 V	0.78	0.78	
	(With indicator light)	(0.81)	(0.87)	
	110 V	0.86 (0.89)	0.86 (0.97)	
	[115 V] (With indicator light)	[0.94 (0.97)]	[0.94 (1.07)]	

Surge voltage suppressor	200 V (With indicator light)	1.18 (1.22)	1.15 (1.30)
	220 V [230 V] (With indicator light)	1.30 (1.34) [1.42 (1.46)]	1.27 (1.46) [1.39 (1.60)]
Indicator light	Diode (Varistor is for DIN terminal and Non-polar type.) LED (AC of DIN connector is neon light)		

Table 2

- Note 1) In common between 110 VAC and 115 VAC, and between 220 VAC and 230 VAC.
- * For 115 VAC and 230 VAC, the allowable voltage is -15% to +5% of rated voltage.
- * S, Z and T type (with power saving circuit) should be used within the following allowable voltage fluctuation range due to a voltage drop caused by the internal circuit.
 S/Z type: 24 VDC: -7% to +10%
 12 VDC: -4% to +10%
 T type: 24 VDC: -8% to +10%
 12 VDC: -6% to +10%
- Note 2) Valve state is not defined if electrical input is outside the specified operating range.
- Note 3) DIN terminal and M8 connector with power saving circuit are not available.
- * For details, refer to the catalogue.

2.3 Port Size

Refer to catalogue.

2.4 Symbol

Refer to catalogue.

2.5 Energization indication

Options 'Z' and 'U' include LED indication of coil energization.

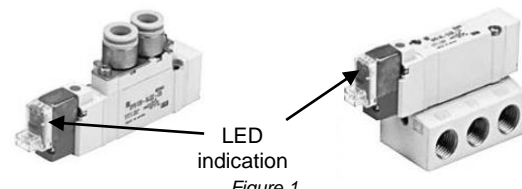

The LED is located on the pilot valve assembly, see Figure 1.

2 Specifications – continued

When the solenoid is energized, the valve switches and the LED remains illuminated while the solenoid is energized.

Caution

Special products might have specifications different from those shown in this section. Contact SMC for specific drawings.

3 Installation

3.1 Installation

Warning

- Do not install the product unless the safety instructions have been read and understood.
- The solenoid valve is an electrical product. For safety, install an appropriate fuse and circuit breaker before use.

3.2 Environment

Warning

- Do not use in an environment where corrosive gases, chemicals, salt water or steam are present.
- Do not use in an explosive atmosphere.
- Do not expose to direct sunlight. Use a suitable protective cover.
- Do not install in a location subject to vibration or impact in excess of the product's specifications.
- Do not mount in a location exposed to radiant heat that would result in temperatures in excess of the product's specifications.
- Products with IP65 enclosures (based on IEC60529) are protected against dust & water; however, these products cannot be used in water.
- Products compliant to IP65 satisfy the specifications through mounting.
- If using in an atmosphere where there is possible contact with water drop-lets, oil, weld spatter, etc., take suitable preventive measures.
- When the solenoid valve is mounted in a control panel or it is energized for a long time, make sure that the ambient temperature is within the specification of the valve.
- Do not use in high humidity environment where condensation can occur.
- Contact SMC for altitude limitations.

3.3 Piping

Caution

- Before connecting piping make sure to clean up chips, cutting oil, dust etc.
- When installing piping or fittings, ensure sealant material does not enter inside the port. When using seal tape, leave 1 thread exposed on the end of the pipe/fitting.
- Tighten fittings to the specified tightening torque.

Connection thread size (R, NPT)	Tightening Torque (N m)
M5	1 to 1.5
1/8	3 to 5
1/4	8 to 12
3/8	15 to 20
1/2	20 to 25

Table 3

3.4 Lubrication

Caution

- SMC products have been lubricated for life at manufacture, and do not require lubrication in service.
- If a lubricant is used in the system, refer to catalogue for details.

3.5 One-touch fittings

3.5.1 Tube attachment and detachment

Caution

Refer to specific Precautions in the catalogue.

3.5.2 Precautions on other tube brands

Caution

When using non-SMC brand tubes, refer to the Specific Precautions in the catalogue.

3.8 Indicator Light/Surge Voltage Suppressor

3 Installation – continued

• Grommet, L/M Plug Connector

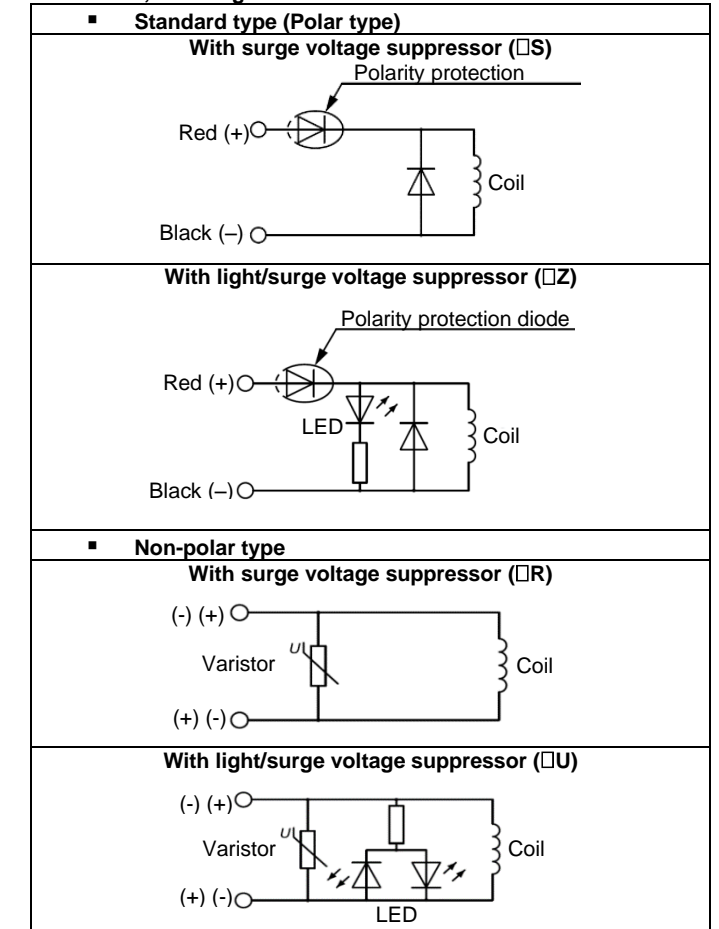

Figure 2

- Connect the standard type in accordance with the +, - polarity indication. (The non-polar type can be used with the connections made either way.)
- Since voltage specifications other than standard 24 VDC and 12 VDC do not have diodes for polarity protection, be careful not to make errors in the polarity.
- When wiring is done at the factory, positive (+) is red and negative (-) is black.

• With power saving circuit

Power consumption is decreased to 1/4 by reducing the wattage required to hold the valve in an energized state. (Effective energizing time is over 62 ms at 24 VDC.)

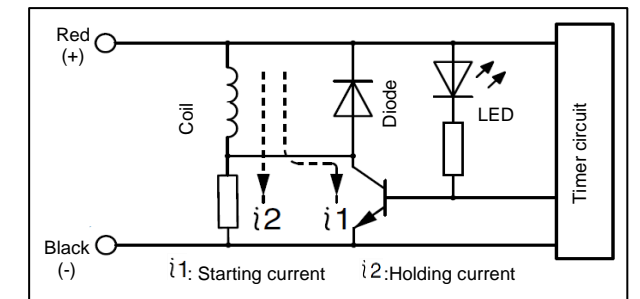

Figure 3

The above circuit reduces the current consumption when holding in order to save energy. Refer to the electrical power waveform as shown below.

- Please be careful not to reverse the polarity, since a diode to prevent the reversed current is not provided for the power saving circuit.
- Please use caution regarding the allowable voltage fluctuation because there is about a 0.5 volt drop due to the transistor. (For details, refer to the solenoid specifications of each type of valve.)

3 Installation – continued

DIN Terminal

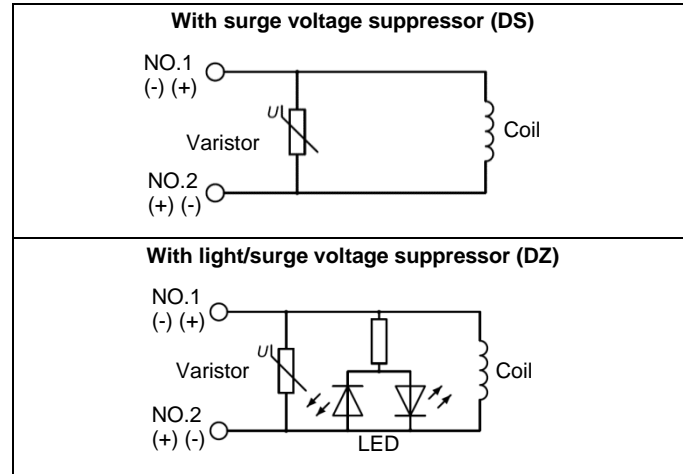

Figure 4

M8 Connector

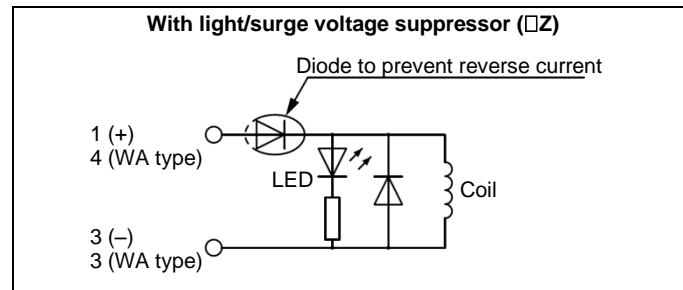
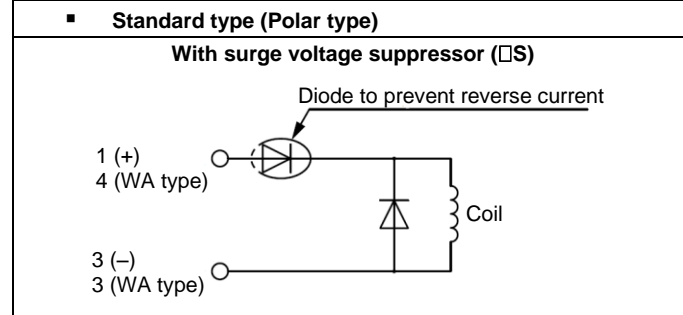

Figure 5

3 Installation – continued

Solenoid valve side pin wiring diagram

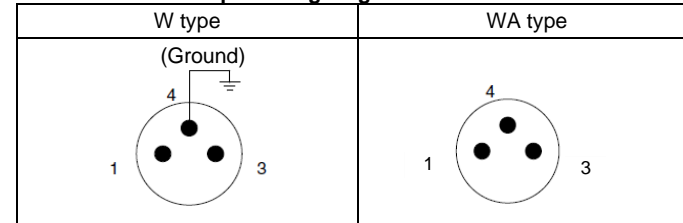

Figure 6

- For the standard type, connect + to 1 and – to 3 for Type W according to polarity, while + to 4 and – to 3 for Type WA.
- For DC voltages other than 12 V and 24 V, incorrect wiring will cause damage to the surge suppressor circuit.
- The WA-type valve cannot be grounded.

<For AC>

(There is no “S” option, because the generation of surge voltage is prevented by a rectifier.)

Grommet, L/M Plug Connector

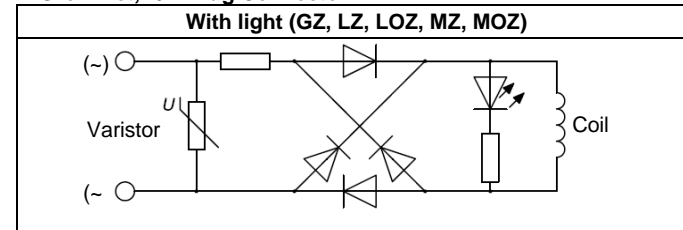

Figure 7

DIN Terminal

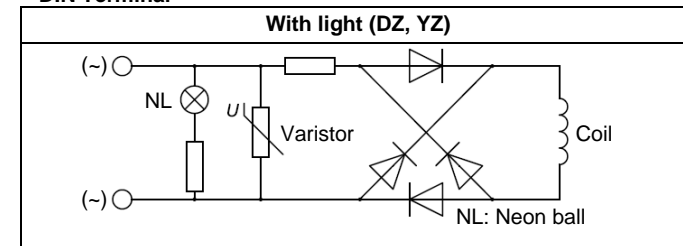

Figure 8

3.8 Circuit diagram with light

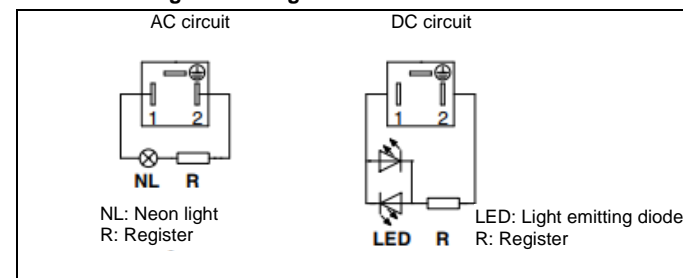

Figure 9

3.9 Residual Voltage

The surge voltage suppressor of a varistor has residual voltage corresponding to the protective element and rated voltage; therefore, protect the controller side from the surge voltage. The residual voltage of the diode is approximately 1V.

3.10 Countermeasure for surge voltage

Caution

At times of sudden interruption of the power supply, the energy stored in a large inductive device may cause non-polar type valves in a de-energised state to switch.

3 Installation – continued

When installing a breaker circuit to isolate the power, consider a valve with polarity (with polarity protection diode), or install a surge absorption diode across the output of the breaker.

3.11 Extended periods of continuous energization

If a valve will be continuously energized for an extended period of time, the temperature of the valve will increase due to the heat generated by the coil. This will likely adversely affect the performance of the solenoid valve and nearby peripheral equipment. Therefore, when it is continuously energized for an extended period of time or when the energized period per day is longer than the de-energized period, use SY series DC specifications or power saving circuit type.

3.12 Valve Mounting

Caution

Mount it so that there is no slippage or deformation in gaskets, and tighten with the tightening torque as shown below.

Model	Thread size	Tightening torque
SY3000	M2	0.16 N m
SY5000	M3	0.8 N m
SY7000	M4	1.4 N m
SY9000	M3	0.8 N m

Table 4

3.13 Manual override

Warning

Regardless of an electric signal for the valve, the manual override is used for switching the main valve. Connected actuator is started by manual operation. Use the manual override after confirming that there is no danger.

Locked manual overrides might prevent the valve responding to being electrically de-energised or cause unexpected movement in the equipment.

Refer to the catalogue for details of manual override operation.

3.14 How to Use Plug Connector

3.14.1 Attaching and detaching connectors

Refer to catalogue for additional details.

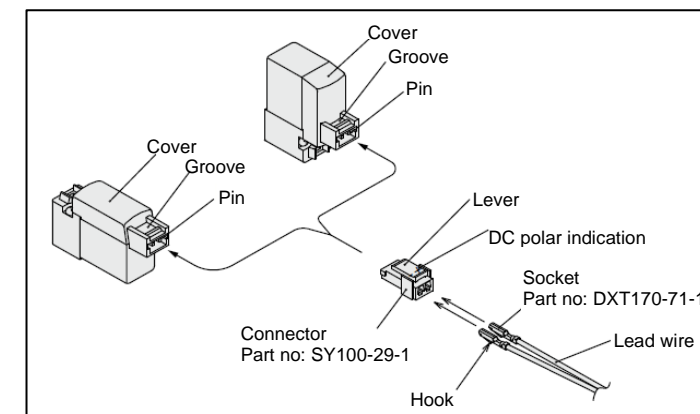

Figure 10

3.14.2 Crimping connection of lead wire and socket

Refer to catalogue for additional details.

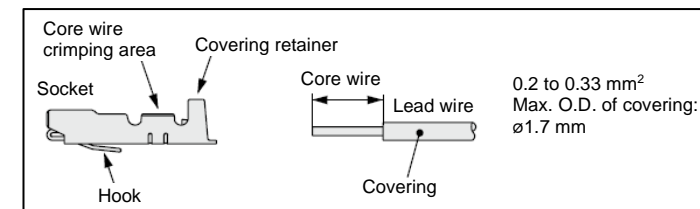

Figure 11

3.14.3 Attaching and detaching lead wires with sockets

Refer to catalogue for additional details.

3 Installation – continued

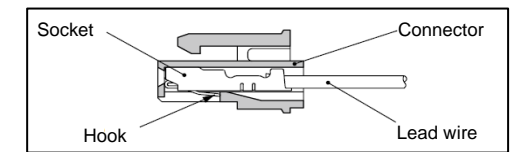

Figure 12

3.15 How to Use DIN Terminal

Refer to catalogue for additional details.

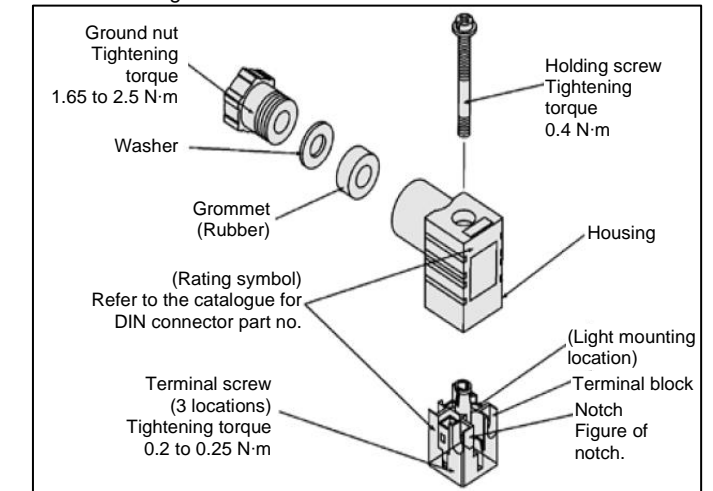

Figure 13

Type “Y”

DIN connector type Y is a DIN connector that conforms to the DIN EN 175301-803 (DIN pitch 8-mm standard).

- D type DIN connector with 9.4 mm pitch between terminals is not interchangeable.
- To distinguish from the D type DIN connector, “N” is listed at the end of voltage symbol. (For connector parts without lights, “N” is not indicated. Please refer to the name plate to distinguish.)
- Dimensions are completely the same as D type DIN connector.

3.15.1 Series SY3000

Caution

- SMC can provide a DIN style terminal connector for the series SY3000. This cannot be assembled to a standard manifold and sub-plate since the DIN connector width (15.8 mm) exceeds that of the valve body (10 mm). Contact SMC if you wish to use with a manifold and sub-plate.

* The DIN style terminal connector and single manifold unit have no external pilot specifications.

3.16 L/M Connector Assembly with Cover

Caution

This connector assembly with cover helps prevent contamination entering the connector.

Refer to catalogue for additional details.

3.17 DIN Rail for Series SY7000/9000

Caution

The DIN rail used with Series SY7000/9000 is stronger than that used with Series SY3000 and SY5000. Use this exclusive DIN rail with Series SY7000 and SY9000. Furthermore, if using a DIN rail other than that supplied by SMC, refer to the manifold mounting section below, and mount using the same method as prescribed for side facing and rear facing, regardless of the mounting orientation.

3 Installation – continued

3.18 DIN rail Manifold Mounting

Caution

For Type 23, 43, 45 45# and 60 DIN rail mounting, when attaching a manifold to a mounting surface, etc., with bolts, if the entire bottom surface of the DIN rail contacts the mounting surface in a horizontal mounting, it can be used by simply securing both ends of the DIN rail. However, for any other mounting method or for side facing and rear facing, etc., secure the DIN rail with bolts at uniform intervals using the following as a guide: 2 to 5 stations at 2 locations, 6 to 10 stations at 3 locations, 11 to 15 stations at 4 locations, 16 to 20 stations at 5 locations. In addition, even in the case of a horizontal mounting, if the mounting surface is subject to vibration, etc., take the same measures indicated above. If secured at fewer than the specified number of locations, warping or twisting may occur in the DIN rail and manifold, causing trouble such as air leakage.

Also, when using mounting screws for the DIN rail on the bottom side (L3 dimension in the dimension table) of the manifold valve body, the height of the screw head has to be as follows:

Type 23, 43 (SY9000): 8 mm or less.

Type 45 (SY3000, 5000): 5.8 mm or less.

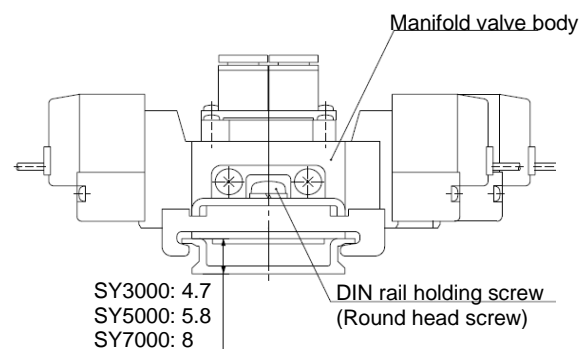

Figure 14 – Type 60

3.19 Tightening torque for DIN rail holding screw

Caution

Refer to catalogue for more details.

The recommended tightening torque for DIN rail holding screw is shown below.

Model	Tightening torque (N·m)
	SY##60 (See figure 14)
SY3000	1
SY5000	1.4
SY7000	1.4

Table 5

3 Installation – continued

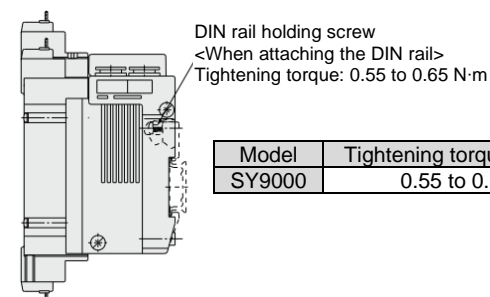

Figure 15 – Example SY9000 Type 43

3.20 M8 connector

Caution

- M8 connector types have an IP65 (enclosure) rating, offering protection from dust and water. However please note: these products are not intended for use in water. Select a SMC connector cable (V100-49-1-□) or a FA sensor type connector, with M8 threaded 3 pin specifications conforming to Nippon Electric Control Equipment Association Standard, NECA4202 (IEC60947-5-2). Make sure the connector O.D. is 10.5 mm or less when used with the SY3000 series manifold. If more than 10.5 mm, it cannot be mounted due to the size.
- Do not use a tool to mount the connector, as this may cause damage. Only tighten by hand (0.4 to 0.6 N·m).
- The excessive stress on the cable connector will not be able to satisfy the IP65 rating. Please use caution and do not apply a stress of 30 N or greater.

Caution

- Failure to meet IP65 performance may result if using alternative connectors than those shown above, or when insufficiently tightened.

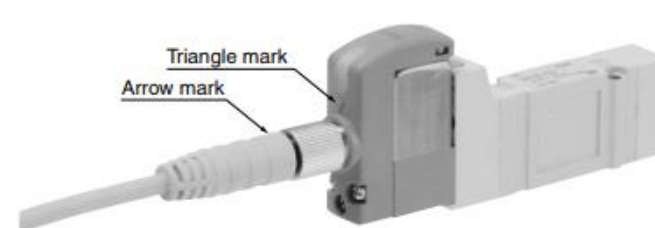

Figure 16

- Note) Connector cable should be mounted in the correct direction. Make sure that the arrow symbol on the connector is facing the triangle symbol on the valve when using SMC connector cable (V100-49-1-□). Be careful not to squeeze it in the wrong direction, as problems such as pin damage may occur.

3.21 Exhaust Throttle

Caution

The SY series pilot valve and main valve share a common exhaust inside the valve. Therefore, do not block the exhaust port when arranging the piping.

3.22 Use as a 3-Port Valve

Caution

The SY3000/5000/7000/9000 series can be used as normally closed (N.C.) or normally open (N.O.) 3-port valves by closing one of the cylinder ports (4(A) or 2(B)) with a plug. However, they should be used with the exhaust ports kept open.

Refer to catalogue for additional details.

3.23 Change of port block assembly

Refer to catalogue.

3.24 Effect of back pressure when using a manifold

Use caution when valves are used on a manifold, because an actuator may malfunction due to back-pressure.

For 3-position exhaust centre valve or single acting cylinder, take appropriate measures to prevent malfunction by using it with an individual EXH interface block or an individual exhaust manifold.

3 Installation – continued

3.25 Supply air

Warning

Use clean air

If the compressed air supply includes chemicals, synthetic materials (including organic solvents), salinity, corrosive gas etc., it can lead to damage or malfunction.

Caution

Install an air filter

Install an air filter upstream of the valve. Select an air filter with a filtration size of 5 μm or smaller.

4 How to Order

4.1 Standard products

Refer to catalogue for 'How to Order'.

4.2 Special products

For special products (-X number) refer to product drawing for 'How to order' details and specifications.

5 Outline Dimensions (mm)

Refer to catalogue for outline dimensions.

6 Maintenance

6.1 General Maintenance

Caution

- Not following proper maintenance procedures could cause the product to malfunction and lead to equipment damage.
- If handled improperly, compressed air can be dangerous.
- Maintenance of pneumatic systems should be performed only by qualified personnel.
- Before performing maintenance, turn off the power supply and be sure to cut off the supply pressure. Confirm that the air is released to atmosphere.
- After installation and maintenance, apply operating pressure and power to the equipment and perform appropriate functional and leakage tests to make sure the equipment is installed correctly.

- If any electrical connections are disturbed during maintenance, ensure they are reconnected correctly and safety checks are carried out as required to ensure continued compliance with applicable national regulations.
- Do not make any modification to the product.
- Do not disassemble the product, unless required by installation or maintenance instructions.
- When the 3-position closed centre type is in its rest position, air can be trapped between the valve and the cylinder. Exhaust this air pressure before removing piping or performing any maintenance.
- When the equipment is operated after remounting or replacement, first confirm that measures are in place to prevent lurching of actuators, etc. Then, confirm that the equipment is operating normally.

6.2 Solenoid Valve for 200, 220 VAC Specifications

Warning

Solenoid valves with DIN-Terminal and L/M type plug connector AC specifications have a built-in rectifier circuit in the pilot section to operate the DC coil.

With 200 V, 220 VAC specification pilot valves, this built-in rectifier generates heat when energized. The surface may become hot depending on the energized condition; therefore, do not touch the solenoid valves.

6.3 Increase manifold stations

Refer to catalogue for details on how to increase manifold stations.

Caution

Make sure that power and air supplies are shut off before disassembly. Furthermore, since air may remain inside the actuator, piping and manifold, confirm that the air is completely exhausted before performing any work.

6.3.1 For SY3000/50000 type 45, 45-A and 45-NA

When disassembly and assembly are performed, air leakage may result if connections between blocks and tightening of the end block's holding screw, is inadequate. Before supplying air, confirm that there are no gaps, etc. between blocks, and that manifold blocks are securely fastened to the DIN rail. Then supply air and confirm that there is no air leakage before operating. The tightening torque for the DIN rail holding screw 1.4 N·m.

6 Maintenance – continued

6.3.2 For SY9000 series type 23, 23P, 43, 43P and 43SA

When disassembly and assembly is performed, if the tightening of the tension bolt is inadequate, it may result in air leakage. The tightening torque for tension bolts is 2.9 N·m.

The tightening torque for the clamp sub assembly screws is 1.4 N·m.

7 Limitations of Use

7.1 Limited warranty and Disclaimer/Compliance Requirements

Refer to Handling Precautions for SMC Products.

Caution

7.2 Leakage voltage

Ensure that any leakage voltage caused by the leakage current when the switching element is OFF causes <3% of the rated voltage across the valve for DC coil and 8% for AC coils.

7.3 Low temperature operation

Unless otherwise indicated in the specifications for each valve, operation is possible to -10°C, but appropriate measures should be taken to avoid solidification or freezing of drainage and moisture, etc.

7.4 Mounting orientation

Mounting orientation is universal.

Warning

7.5 Air returned spool valves

The use of 2-position single valves with air returned spools has to be carefully considered.

The return of the valve spool into the de-energized position depends on the pilot pressure. If the pilot pressure drops below the specified operating pressure the position of the spool cannot be defined. The design of the system must take into account such behaviour.

Additional measures might be necessary. For example, the installation of an additional air tank to maintain the pilot pressure.

Energy source status	Single	Double	3 position
Air supply present, electricity cut	Spool returns to the off position by air force	Spool stops moving after electricity cut (Position cannot be defined)	Spool returns to off position by spring force
Air supply cut before electricity cut	Spool stops moving after air pressure cut (Position cannot be defined)	Spool stops moving after air pressure cut (Position cannot be defined)	Spool returns to off position by spring force

Table 6

7.6 Safety relays

If a safe output from a safety relay or PLC is used to operate this valve, ensure that any output test pulse duration is shorter than 1 ms to avoid the valve solenoid responding.

8 Product disposal

This product should not be disposed of as municipal waste. Check your local regulations and guidelines to dispose this product correctly, in order to reduce the impact on human health and the environment.

9 Contacts

Refer to www.smworld.com or www.smc.eu for contacts.

SMC Corporation

URL : <http://www.smworld.com> (Global) <http://www.smc.eu> (Europe)
 'SMC Corporation, Akihabara UDX15F, 4-14-1, Sotokanda, Chiyoda-ku, Tokyo 100 0021
 Specifications are subject to change without prior notice from the manufacturer.
 © 2020 SMC Corporation All Rights Reserved.
 Template DKP50047-F-085I