

Body Ported Type Vacuum Ejector **New**

RoHS

Compact and Lightweight

Overall length Max. **11 %** reduction
(6.7 mm shorter)

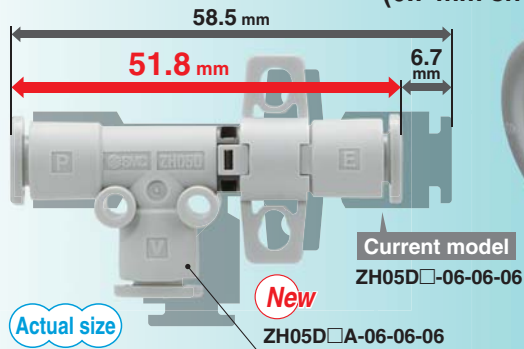

Port height Max. **25 %** reduction (9.1 mm shorter)



Weight Max. **74 %** reduction (65.1 g lighter)



4 mounting types

Direct mounting



Standard bracket mounting



L-bracket mounting



DIN rail mounting



Variations

Model	Nozzle nominal size [mm]	Vacuum pressure reached* [kPa]		Maximum suction flow rate [l/min (ANR)]		Air consumption [l/min (ANR)]
		Type S	Type L	Type S	Type L	
ZH05D□A	0.5	-90	-48	6	13	13
ZH07D□A	0.7			12	28	27
ZH10D□A	1.0			26	52	52
ZH13D□A	1.3			40	78	84
ZH15D□A	1.5			58	78	113
ZH18D□A	1.8	-66	-66	76	128	162
ZH20D□A	2.0			90	155	196

* Supply pressure: 0.45 MPa

Series ZH



CAT.EUS100-109A-UK

Piping Variations

One-touch connection

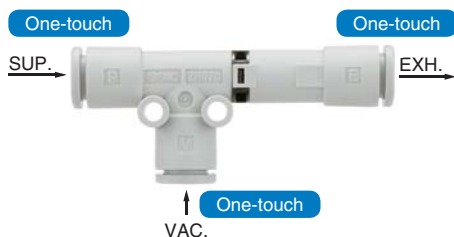

Metric			
SUP.	VAC.	EXH.	Model
Ø 6*	Ø 6*	Ø 6*	ZH05D□A ZH07D□A
Ø 6*	Ø 6*	Ø 8	ZH10D□A
Ø 8	Ø 10	Ø 10	ZH13D□A ZH15D□A
Ø 10	Ø 12	Ø 12	ZH18D□A ZH20D□A

Inch			
SUP.	VAC.	EXH.	Model
Ø 1/4"	Ø 1/4"	Ø 1/4"	ZH05D□A ZH07D□A
Ø 1/4"	Ø 1/4"	Ø 5/16"	ZH10D□A
Ø 5/16"	Ø 3/8"	Ø 3/8"	ZH13D□A ZH15D□A
Ø 3/8"	Ø 1/2"	Ø 1/2"	ZH18D□A ZH20D□A

*Oval release button is only available with Ø 6.

One-touch and screw-in connection



SUP.	VAC.	EXH.	Model
Ø 6*	Rc 1/8	Ø 6*	ZH05D□A ZH07D□A
Ø 8	Rc 1/8	Ø 8	ZH10D□A
Ø 8	Rc 1/4	Ø 10	ZH13D□A
Ø 8	Rc 3/8	Ø 10	ZH15D□A
Ø 10	Rc 3/8	Ø 12	ZH18D□A
Ø 10	Rc 1/2	Ø 12	ZH20D□A

SUP.	VAC.	EXH.	Model
Ø 1/4"	NPT 1/8	Ø 1/4"	ZH05D□A ZH07D□A
Ø 1/4"	NPT 1/8	Ø 5/16"	ZH10D□A
Ø 5/16"	NPT 1/4	Ø 3/8"	ZH13D□A
Ø 5/16"	NPT 3/8	Ø 3/8"	ZH15D□A
Ø 3/8"	NPT 3/8	Ø 1/2"	ZH18D□A
Ø 3/8"	NPT 1/2	Ø 1/2"	ZH20D□A

*Oval release button is only available with Ø 6.

Screw-in connection



SUP.	VAC.	EXH.	Model
Rc 1/8	Rc 1/8	Rc 1/8	ZH05D□A ZH07D□A ZH10D□A
Rc 1/8	Rc 1/4	Rc 1/4	ZH13D□A
Rc 1/4	Rc 3/8	Rc 3/8	ZH15D□A
Rc 3/8	Rc 3/8	Rc 3/8	ZH18D□A
Rc 3/8	Rc 1/2	Rc 1/2	ZH20D□A

SUP.	VAC.	EXH.	Model
NPT 1/8	NPT 1/8	NPT 1/8	ZH05D□A ZH07D□A ZH10D□A
NPT 1/8	NPT 1/4	NPT 1/4	ZH13D□A
NPT 1/4	NPT 3/8	NPT 3/8	ZH15D□A
NPT 3/8	NPT 3/8	NPT 3/8	ZH18D□A
NPT 3/8	NPT 1/2	NPT 1/2	ZH20D□A

Easy identification of product type

	Release button colour	
Metric		Light grey
Inch		Orange

Silencer and standard bracket are available.

* Shipped together with the product.



*1 Silencer can only be connected to One-touch fitting in EXH. port.
*2 Mounting is interchangeable with the current model. Refer to page 12 for mounting.

Box Type Vacuum Ejector (Built-in Silencer)

Nozzle size: Ø 0.5, Ø 0.7, Ø 1.0, Ø 1.3

For details, refer to the WEB catalogue.



Body Ported Type Vacuum Ejector

Series ZH



How to Order

Note Refer to "Table 1" and "Table 2" for the combination available for SUP., VAC. and EXH. port connection.

Body Ported **ZH 10 D S A - 06 - 06 - 08**

Nozzle size

05	Ø 0.5 mm
07	Ø 0.7 mm
10	Ø 1.0 mm
13	Ø 1.3 mm
15	Ø 1.5 mm
18	Ø 1.8 mm
20	Ø 2.0 mm

Body ported

Vacuum pressure reached

S	-90 kPa
L	-48 kPa (ZH05 to 13D□A)
L	-66 kPa (ZH15 to 20D□A)

Port (SUP./VAC./EXH.) size (Note)

One-touch fittings

Metric size		Inch size	
06	Ø 6	07	Ø 1/4"
08	Ø 8	09	Ø 5/16"
10	Ø 10	11	Ø 3/8"
12	Ø 12	13	Ø 1/2"

Female threads

Metric size		Inch size	
01	Rc 1/8	N01	NPT 1/8
02	Rc 1/4	N02	NPT 1/4
03	Rc 3/8	N03	NPT 3/8
04	Rc 1/2	N04	NPT 1/2

Accessories

(Standard bracket/Silencer)^{*2}

Symbol	Standard bracket	Silencer
—	●	×
N	×	×
S ^{*1}	●	●
NS ^{*1}	×	●

*1 Options S and NS are not available for EXH. port with a screw-in connection.

*2 Each accessory is not assembled with the product, but shipped together.

- Silencer can only be selected for EXH. port with One-touch fitting.
- The silencer part number depends on the size of the EXH. port.

EXH. port	Silencer part no.
06	AN10-C06
07	AN10-C07
08	AN15-C08
09	AN15-C08
10	AN20-C10
11	AN20-C11
12	AN30-C12

* No silencer available for ZH18/20D□A in inch size for EXH. port size '13'. In that case, select the screw-in connection, and order silencer AN30-N03 and AN40-N04 separately. For details about silencers, refer to the AN series in the **WEB catalogue** in www.smc.eu.

Note Refer to "Table 1" and "Table 2" for the combination available for SUP., VAC. and EXH. port connection.

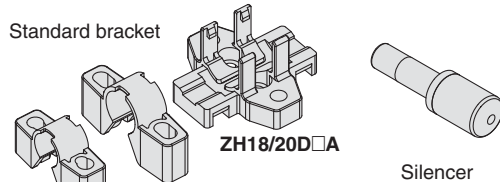

Table 1 Metric Size

Model	SUP. VAC. EXH.			SUP.	VAC.	EXH.
	SUP.	VAC.	EXH.			
ZH05D□A-	06 — 06 — 06	One-touch	One-touch	One-touch		
	06 — 01 — 06	One-touch	Screw-in	One-touch		
	01 — 01 — 01	Screw-in	Screw-in	Screw-in		
ZH07D□A-	06 — 06 — 06	One-touch	One-touch	One-touch		
	06 — 01 — 06	One-touch	Screw-in	One-touch		
	01 — 01 — 01	Screw-in	Screw-in	Screw-in		
ZH10D□A-	06 — 06 — 08	One-touch	One-touch	One-touch		
	06 — 01 — 08	One-touch	Screw-in	One-touch		
	01 — 01 — 01	Screw-in	Screw-in	Screw-in		
ZH13D□A-	08 — 10 — 10	One-touch	One-touch	One-touch		
	08 — 02 — 10	One-touch	Screw-in	One-touch		
	01 — 02 — 02	Screw-in	Screw-in	Screw-in		
ZH15D□A-	08 — 10 — 10	One-touch	One-touch	One-touch		
	08 — 03 — 10	One-touch	Screw-in	One-touch		
	02 — 03 — 03	Screw-in	Screw-in	Screw-in		
ZH18D□A-	10 — 12 — 12	One-touch	One-touch	One-touch		
	10 — 03 — 12	One-touch	Screw-in	One-touch		
	03 — 03 — 03	Screw-in	Screw-in	Screw-in		
ZH20D□A-	10 — 12 — 12	One-touch	One-touch	One-touch		
	10 — 04 — 12	One-touch	Screw-in	One-touch		
	03 — 04 — 04	Screw-in	Screw-in	Screw-in		

*3 Screw-in: Rc female threads

Table 2 Inch Size

Model	SUP. VAC. EXH.			SUP.	VAC.	EXH.
	SUP.	VAC.	EXH.			
ZH05D□A-	07 — 07 — 07	One-touch	One-touch	One-touch		
	07 — N01 — 07	One-touch	Screw-in	One-touch		
	N01 — N01 — N01	Screw-in	Screw-in	Screw-in		
ZH07D□A-	07 — 07 — 07	One-touch	One-touch	One-touch		
	07 — N01 — 07	One-touch	Screw-in	One-touch		
	N01 — N01 — N01	Screw-in	Screw-in	Screw-in		
ZH10D□A-	07 — 07 — 09	One-touch	One-touch	One-touch		
	07 — N01 — 09	One-touch	Screw-in	One-touch		
	N01 — N01 — N01	Screw-in	Screw-in	Screw-in		
ZH13D□A-	09 — 11 — 11	One-touch	One-touch	One-touch		
	09 — N02 — 11	One-touch	Screw-in	One-touch		
	N01 — N02 — N02	Screw-in	Screw-in	Screw-in		
ZH15D□A-	09 — 11 — 11	One-touch	One-touch	One-touch		
	09 — N03 — 11	One-touch	Screw-in	One-touch		
	N02 — N03 — N03	Screw-in	Screw-in	Screw-in		
ZH18D□A-	11 — 13 — 13	One-touch	One-touch	One-touch		
	11 — N03 — 13	One-touch	Screw-in	One-touch		
	N03 — N03 — N03	Screw-in	Screw-in	Screw-in		
ZH20D□A-	11 — 13 — 13	One-touch	One-touch	One-touch		
	11 — N04 — 13	One-touch	Screw-in	One-touch		
	N03 — N04 — N04	Screw-in	Screw-in	Screw-in		

*4 Screw-in: NPT female threads

Series ZH

L-Bracket / DIN Rail Mounting Bracket

When using the ejectors with a clamp mount, order parts ①, ② and ③ below separately.

① L-Bracket

Part no.	Applicable model	Note	Quantity
AS-10L	ZH05/07/10D□A	Applicable thread size: M3	1 pc.
AS-25L	ZH13/15D□A	Applicable thread size: M4	
AS-30L	ZH18/20D□A	Applicable thread size: M4	

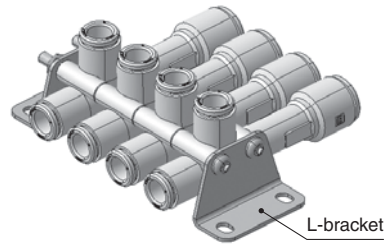

② DIN Rail Mounting Bracket*1

Part no.	Applicable model	Note	Quantity
AS-10D	ZH05/07/10D□A	Applicable thread size: M3	1 pc.
AS-25D	ZH13/15D□A	Applicable thread size: M4	
AS-30D	ZH18/20D□A	Applicable thread size: M4	

*1 DIN rail is not included. It should be provided by the customer.

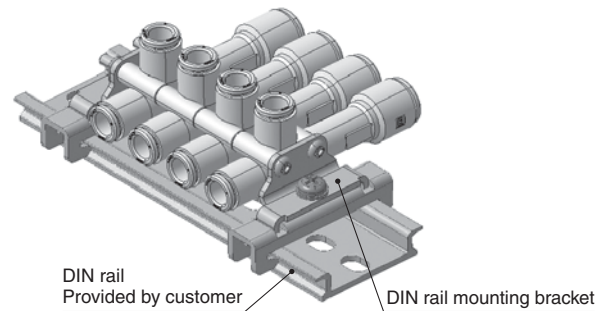

③ Set of Long Clamping Screws*1

Part no.	Applicable model	Stations	Contents*2	
			Screw	Accessories
ZH2-TB101-A	ZH05D□A ZH07D□A ZH10D□A	1	M3 x 20 2 pcs.	· Hexagon nut (M3) 2 pcs. · Flat washer (for M3) 2 pcs.
ZH2-TB102-A		2	M3 x 35 2 pcs.	
ZH2-TB103-A		3	M3 x 50 2 pcs.	
ZH2-TB104-A		4	M3 x 65 2 pcs.	
ZH2-TB106-A		6	M3 x 95 2 pcs.	
ZH2-TB108-A		8	M3 x 125 2 pcs.	
ZH2-TB201-A	ZH13D□A ZH15D□A	1	M4 x 30 2 pcs.	· Hexagon nut (M4) 2 pcs. · Flat washer (for M4) 2 pcs.
ZH2-TB202-A		2	M4 x 50 2 pcs.	
ZH2-TB203-A		3	M4 x 70 2 pcs.	
ZH2-TB204-A		4	M4 x 90 2 pcs.	
ZH2-TB206-A		6	M4 x 130 2 pcs.	
ZH2-TB208-A		8	M4 x 170 2 pcs.	
(ZH2-TB201-A)*3	ZH18D□A ZH20D□A	1	M4 x 30 2 pcs.	· Hexagon nut (M4) 2 pcs. · Flat washer (for M4) 2 pcs.
ZH2-TB302-A		2	M4 x 55 2 pcs.	
ZH2-TB303-A		3	M4 x 80 2 pcs.	
ZH2-TB304-A		4	M4 x 100 2 pcs.	
ZH2-TB306-A		6	M4 x 145 2 pcs.	
ZH2-TB308-A		8	M4 x 185 2 pcs.	

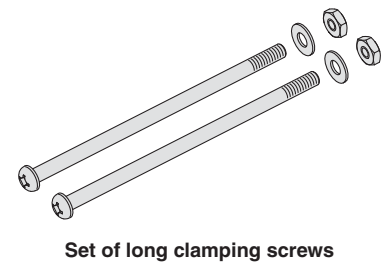

Set of long clamping screws

*1 Select only One-touch fitting if ZH ejectors are to be clamped. The screw-in connectors cannot be used as they will interfere with each other when clamped together. Refer to page 9 and 10 to find the models for which clamp mounting is not available.

*2 The material of the nut and bolt is carbon steel with a trivalent chromate surface treatment.

*3 The same screw set is used for 1 station of ZH13/15D□A and ZH18/20D□A.

Ordering Example*

ZH10DSA 4 products are clamped with L bracket.

- ① ZH10DSA-06-06-08N 4 pcs.
- ② AS-10L 2 pcs.
- ③ ZH2-TB104-A 1 set (2 pcs. included)

* The products are not assembled. M3: Assemble the products with 0.315 ± 0.03 N·m, M4: 0.76 ± 0.08 N·m.

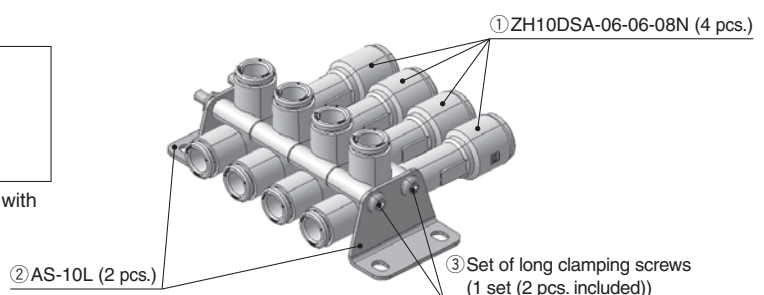

Specifications



Body Ported

Operating temperature range	-5 to 50°C*1
Fluid	Air
Applicable tubing material	Nylon, Soft nylon, Polyurethane
Operating pressure range	0.1 to 0.6 MPa*2

*1 No freezing

*2 This is a supply pressure to supply (P) port. Vacuum (V) and exhaust (E) port should not be sealed simultaneously.

Ejector Specifications*1

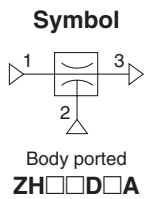

Model	Nozzle nominal size [mm]	Vacuum pressure reached*2 [kPa]		Maximum suction flow rate [l/min(ANR)]		Air consumption [l/min(ANR)]	Weight*3 [g]
		Type S	Type L	Type S	Type L		
ZH05D□A	0.5	-90	-48	6	13	13	5.0
ZH07D□A	0.7			12	28	27	5.2
ZH10D□A	1.0			26	52	52	6.1
ZH13D□A	1.3			40	78	84	12.4
ZH15D□A	1.5	-66		58	78	113	13.4
ZH18D□A	1.8			76	128	162	22.2
ZH20D□A	2.0			90	155	196	23.3

*1 The values indicating characteristics are representative values, and may vary depending on the atmospheric pressure (weather, altitude, etc.).

*2 Supply pressure: 0.45 MPa

*3 Weight for the One-touch fitting type (Except standard bracket)

Construction

Body Ported

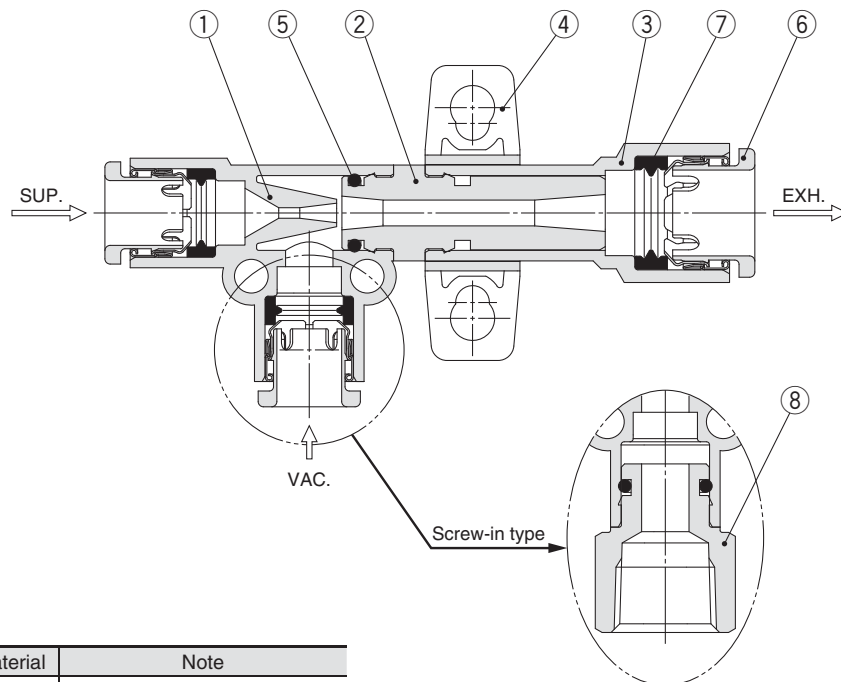

Component Parts

No.	Description	Material	Note
1	Body	PBT	
2	Diffuser	PPS	Type S: Brown, Type L: Black
3	Adapter	PBT	
4	Standard bracket	PBT	Detachable (Accessory)
5	O-ring	NBR	Grease applied
6	Cassette	—	
7	Seal	NBR	Grease applied
8	Screw-in stud	Brass	Electroless nickel plating

Exhaust Characteristics / Flow Rate Characteristics (Representative value)

(Flow rate characteristics: Supply pressure: 0.45 MPa)

ZH05□SA

Exhaust Characteristics

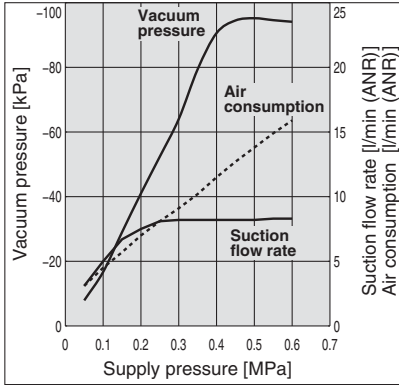

Flow Rate Characteristics

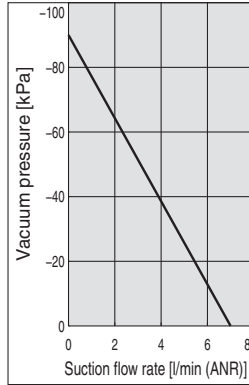

ZH05□LA

Exhaust Characteristics

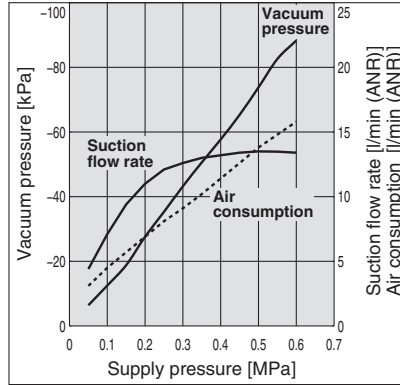

Flow Rate Characteristics

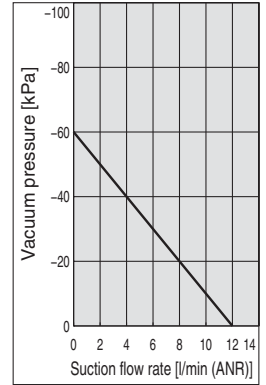

ZH07□SA

Exhaust Characteristics

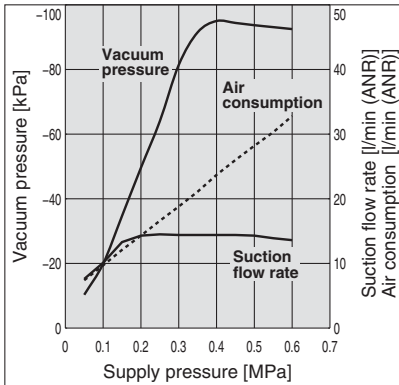

Flow Rate Characteristics

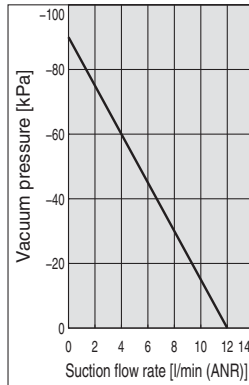

ZH07□LA

Exhaust Characteristics

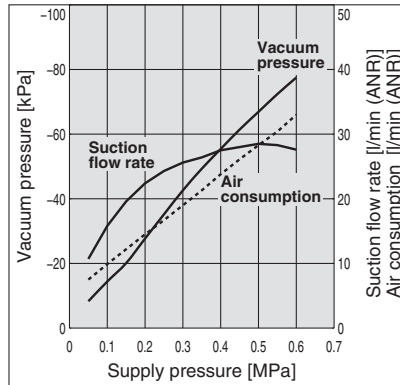

Flow Rate Characteristics

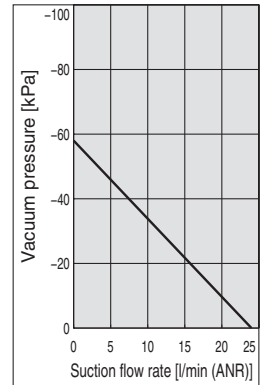

ZH10□SA

Exhaust Characteristics

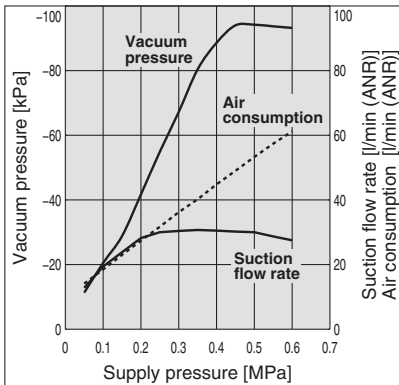

Flow Rate Characteristics

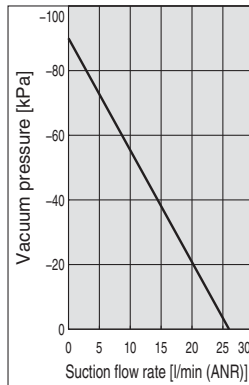

ZH10□LA

Exhaust Characteristics

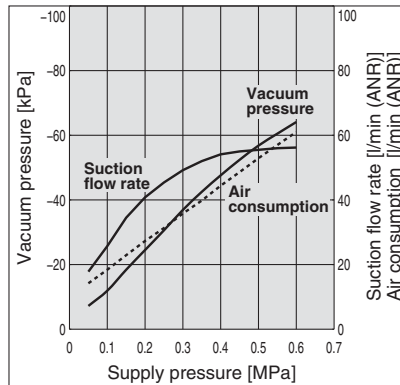

Flow Rate Characteristics

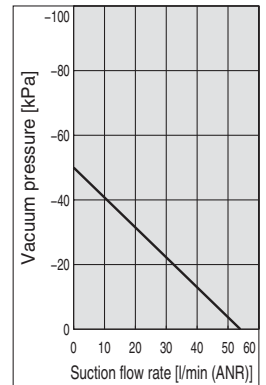

ZH13□SA

Exhaust Characteristics

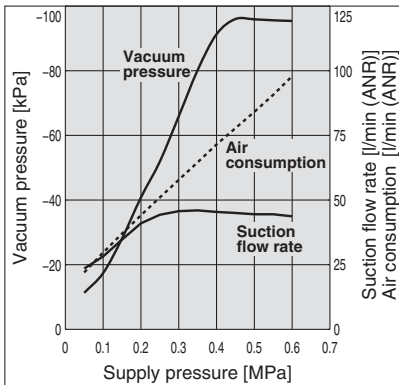

Flow Rate Characteristics

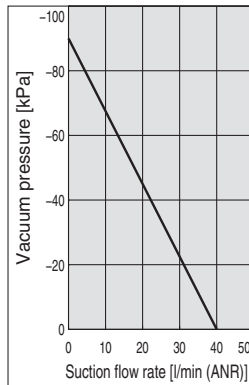

ZH13□LA

Exhaust Characteristics

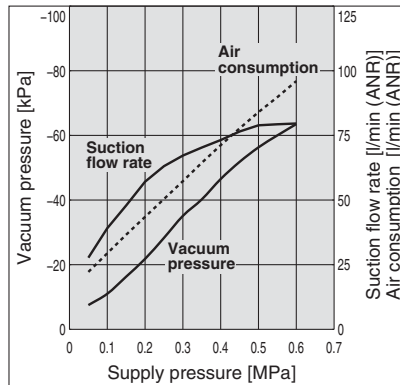

Flow Rate Characteristics

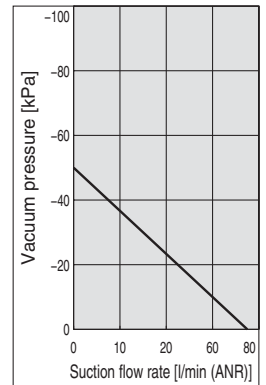

Exhaust Characteristics / Flow Rate Characteristics (Representative value)

(Flow rate characteristics: Supply pressure: 0.45 MPa)

ZH15□SA

Exhaust Characteristics

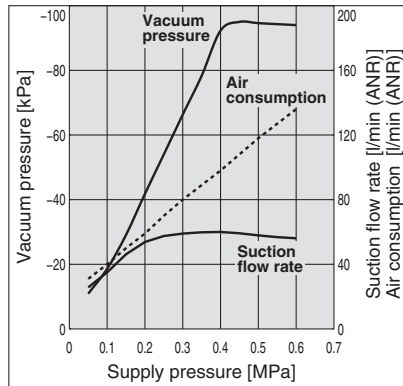

Flow Rate Characteristics

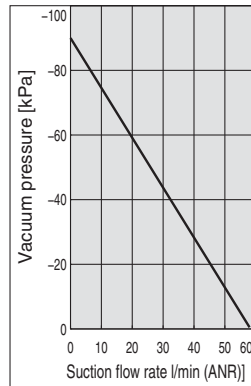

ZH15□LA

Exhaust Characteristics

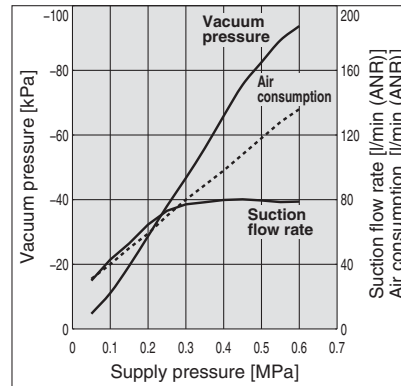

Flow Rate Characteristics

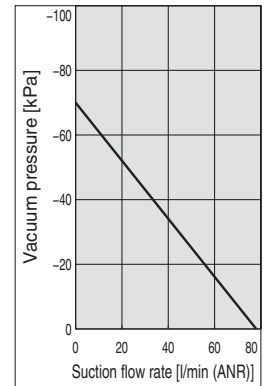

ZH18□SA

Exhaust Characteristics

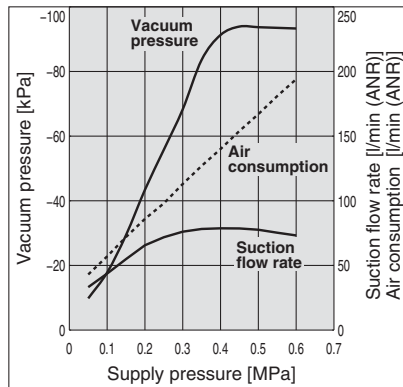

Flow Rate Characteristics

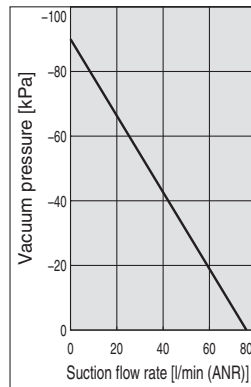

ZH18□LA

Exhaust Characteristics

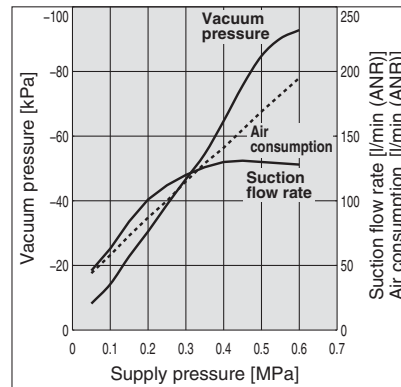

Flow Rate Characteristics

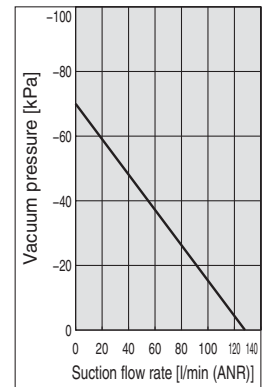

ZH20□SA

Exhaust Characteristics

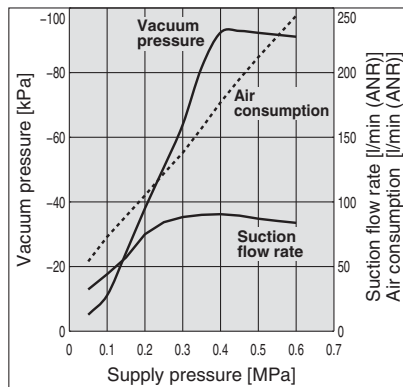

Flow Rate Characteristics

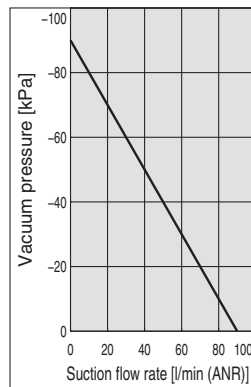

ZH20□LA

Exhaust Characteristics

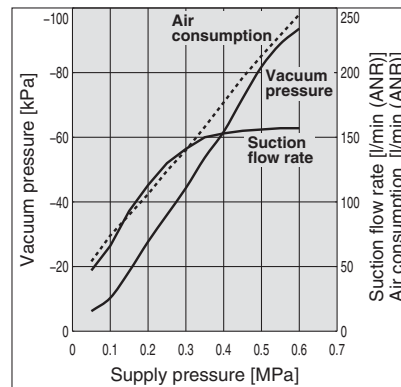

Flow Rate Characteristics

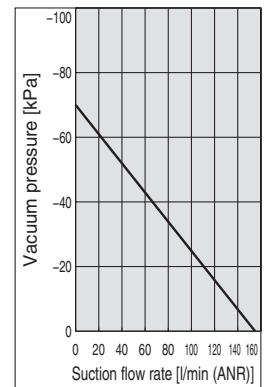

How to Read Flow Rate Characteristics Graph

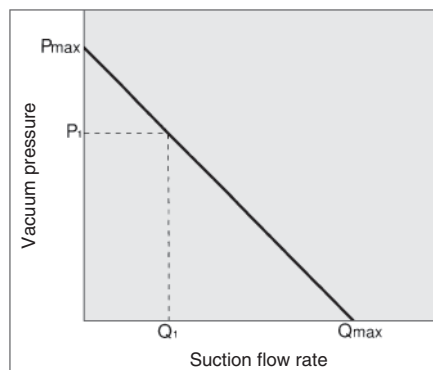

Flow rate characteristics are expressed in ejector vacuum pressure and suction flow. If suction flow changes, the vacuum pressure will also be changed. Normally this relationship is expressed in ejector standard operating pressure use. In graph, Pmax is maximum vacuum pressure and Qmax is maximum suction flow. The values are specified according to catalogue use. Changes in vacuum pressure are expressed in the below order.

1. When ejector suction port is covered and made airtight, suction flow becomes zero and vacuum pressure is at maximum value (Pmax).
2. When suction port is opened gradually, air can flow through, (air leakage), suction flow increases, but vacuum pressure decreases. (condition P1 and Q1)

3. When suction port is opened further and fully opened, suction flow moves to maximum value (Qmax), but vacuum pressure is near zero (atmospheric pressure).

As described above, the vacuum pressure changes when the suction flow changes. In other words, when there is no leakage from the vacuum port, the vacuum pressure can reach its maximum, but as the amount of leakage increases, the vacuum pressure decreases. When the amount of leakage and the maximum suction flow become equal, the vacuum pressure becomes almost zero. In the case when ventilative or leaky workpiece should be adsorbed, take note that vacuum pressure will not rise.

Series ZH

Body Ported: ZH05D^SA-□-□-□ to ZH20D^SA-□-□-□

One-touch connection

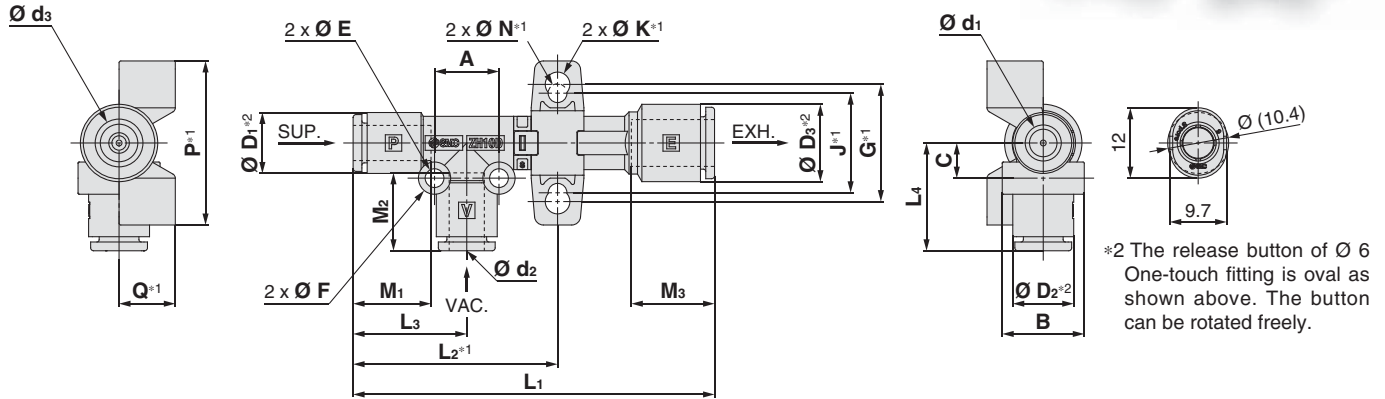

All Ports: One-touch Fitting

	Model	D1	D2	D3	d1	d2	d3	M1	M2	M3	L1	L2*1	L3	L4	A	B	C	E	F	G*1	J*1	K*1	N*1	P*1	Q*1	
Metric	ZH05D□A-06-06-06										51.8															
	ZH07D□A-06-06-06	10.4	10.4	10.4	6	6	6	13.3	13.3	13.3	55	34.9	19.4	18.4	11	14	6	3.2	5.5	20	17		3.2	28	9.6	
	ZH10D□A-06-06-08			13.2			8				14.2	61.7										4.2				
	ZH13D□A-08-10-10	13.2	15.9	15.9	8	10	10	14.2	15.6	15.6	71.8	43.9												4.2	35	12
	ZH15D□A-08-10-10										83.6	51.4	22.4	24.4	17	20	9		7.8	27	22					
	ZH18D□A-10-12-12	15.9	18.5	18.5	10	12	12	15.6	17	17	105.7	60.9	28.4	26.4	22	22	10	4.3	8	Refer to the standard bracket dimensions.						
Inch	ZH05D□A-07-07-07										51.8															
	ZH07D□A-07-07-07	11.15	11.15	11.15	1/4"	1/4"	1/4"	13.3	13.3	13.3	55	34.9	19.4	18.4	11	14	6	3.2	5.5	20	17		3.2	28	9.6	
	ZH10D□A-07-07-09			13.2			5/16"				14.2	61.7										4.2				
	ZH13D□A-09-11-11	13.2	15.45	15.45	5/16"	3/8"	3/8"	14.2	15.6	15.6	71.8	43.9	22.4	24.4	17	20	9		7.8	27	22			4.2	35	12
	ZH15D□A-09-11-11										83.6	51.4														
	ZH18D□A-11-13-13	15.45	19.3	19.3	3/8"	1/2"	1/2"	15.6	17	17	105.7	60.9	28.4	26.4	22	22	10	4.3	8	Refer to the standard bracket dimensions.						
ZH20D□A-11-13-13										112.2	62.2															

*1 Dimensions when the standard bracket is mounted

Body Ported: ZH₂₀D^{18S}A-□-□-□

Standard bracket

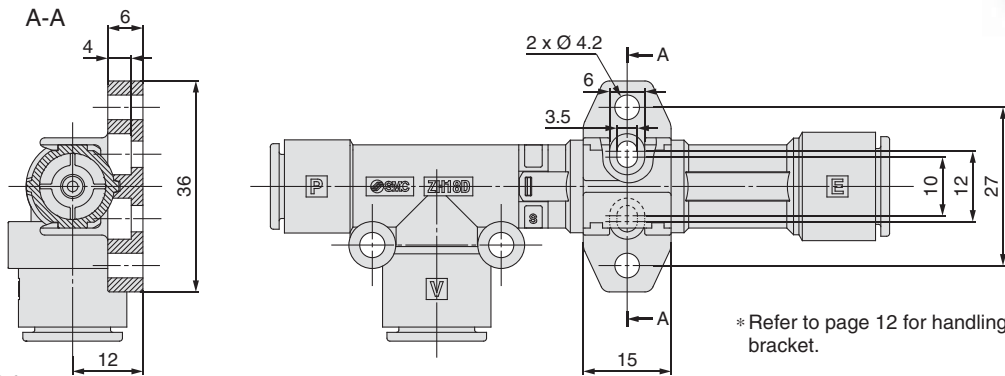

Silencer

ZH05 to 15D□A

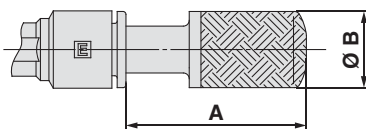

ZH18/20D□A-□-□-12

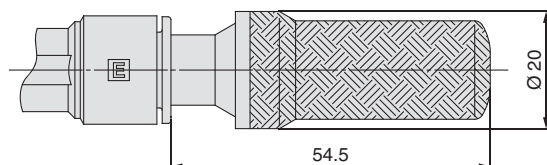

Model	A	Ø B
ZH05D□A-□-□-06/07	23.2	11
ZH07D□A-□-□-06/07		
ZH10D□A-□-□-08/09	30.8	13
ZH13D□A-□-□-10/11	41.9	16.5
ZH15D□A-□-□-10/11		

* Directly mounted silencer not available for 1/2" EXH. port of ZH18/20D□A.

* The standard bracket and silencer are not assembled with the product, but shipped together.



Body Ported: ZH05D^SA-□-□-□ to ZH20D^SA-□-□-□

One-touch and screw-in connection

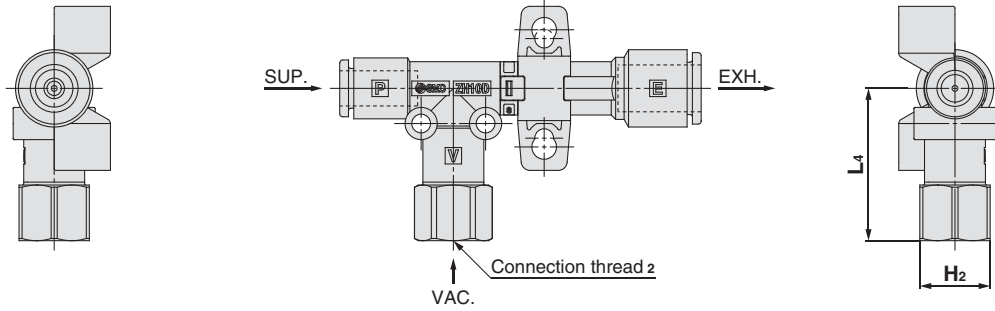

V Port: Screw-in
P/E Port: One-touch Fitting

	Model	H ₂	L ₄	Connection thread 2
Metric	ZH05D□A-06-01-06	12	26	Rc 1/8
	ZH07D□A-06-01-06			
	ZH10D□A-06-01-08			
	ZH13D□A-08-02-10	17	36.3	Rc 1/4
	ZH15D□A-08-03-10			
	ZH18D□A-10-03-12	19	39.1	Rc 3/8
ZH20D□A-10-04-12	24	44.1	Rc 1/2	
Inch	ZH05D□A-07-N01-07	12.7	26	NPT 1/8
	ZH07D□A-07-N01-07			
	ZH10D□A-07-N01-09			
	ZH13D□A-09-N02-11	17.46	36.3	NPT 1/4
	ZH15D□A-09-N03-11			
	ZH18D□A-11-N03-13	22.23	39	NPT 3/8
ZH20D□A-11-N04-13	23.81	44.1	NPT 1/2	

Screw-in connection

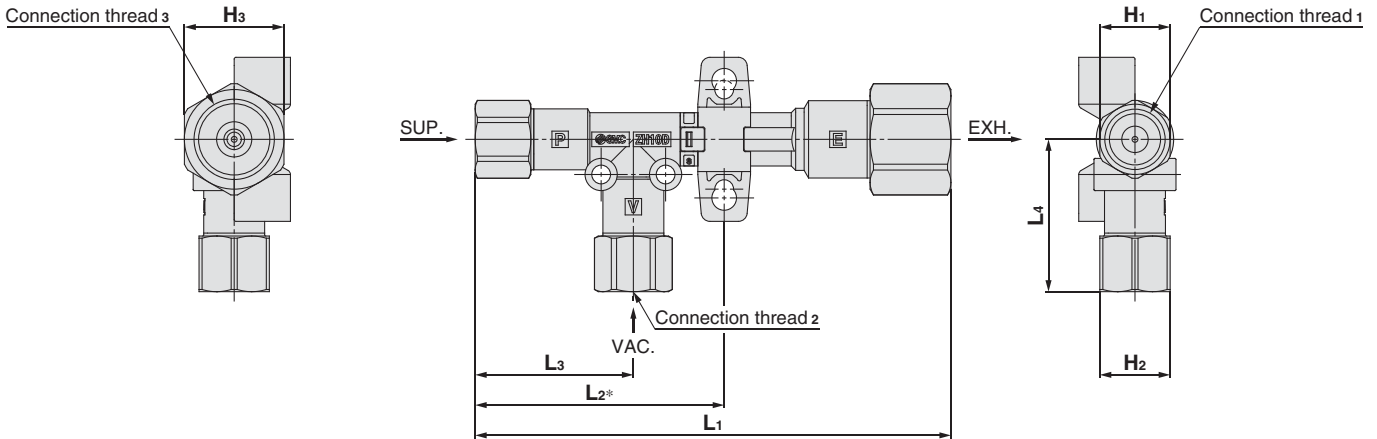

All Ports: Screw-in

	Model	H ₁	H ₂	H ₃	L ₁	L ₂ *	L ₃	L ₄	Connection thread 1	Connection thread 2	Connection thread 3
Metric	ZH05D□A-01-01-01	12	12	12	67	42.5	27	26	Rc 1/8	Rc 1/8	Rc 1/8
	ZH07D□A-01-01-01				70.2						
	ZH10D□A-01-01-01				76.4						
	ZH13D□A-01-02-02	17	17	17	90.8	51	29.5	36.3	Rc 1/4	Rc 1/4	Rc 1/4
	ZH15D□A-02-03-03				108.2	63.3	34.3	37.1			
	ZH18D□A-03-03-03	19	19	19	131.1	73.6	41.1	39.1	Rc 3/8	Rc 3/8	Rc 3/8
ZH20D□A-03-04-04	142.6				74.9	44.1		Rc 1/2			
Inch	ZH05D□A-N01-N01-N01	12.7	12.7	12.7	67	42.5	27	26	NPT 1/8	NPT 1/8	NPT 1/8
	ZH07D□A-N01-N01-N01				70.2						
	ZH10D□A-N01-N01-N01				76.4						
	ZH13D□A-N01-N02-N02	17.46	17.46	17.46	90.8	51	29.5	36.3	NPT 1/4	NPT 1/4	NPT 1/4
	ZH15D□A-N02-N03-N03				108.2	63.3	34.3	37.1			
	ZH18D□A-N03-N03-N03	22.23	22.23	22.23	131	73.6	41.1	39	NPT 3/8	NPT 3/8	NPT 3/8
ZH20D□A-N03-N04-N04	142.6				74.9	44.1		NPT 1/2			

* Dimensions when the standard bracket is mounted

Series ZH

Body Ported: ZH05D^SL□-□-□-□ to ZH20D^SL□-□-□-□

L-bracket (Bracket on a single side)*

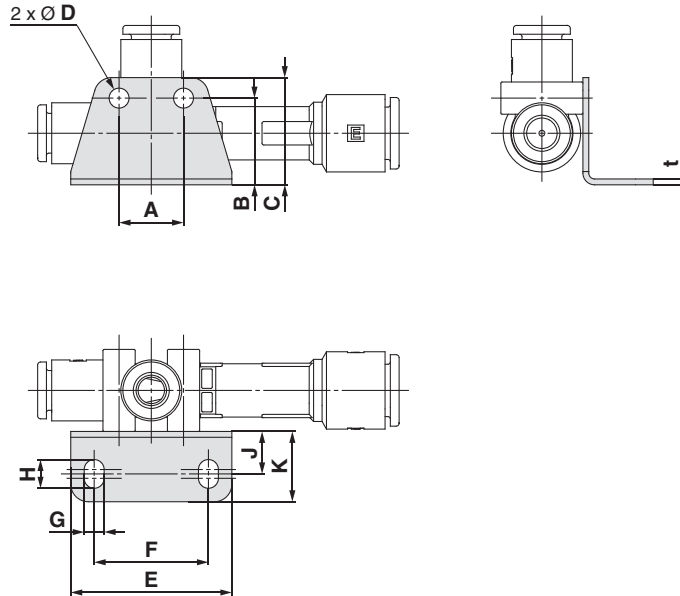

* Long clamping screw set for 1 station required for assembly needs to be ordered separately. Refer to page 3.

L-bracket (Brackets on both sides)*

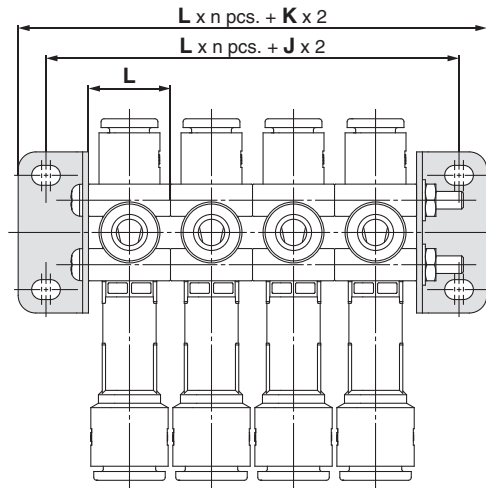

* Long clamping screw set which is required for assembly needs to be ordered separately. Refer to page 3.

* ZH15D□A-09-N03-11
 ZH15D□A-N02-N03-N03
 ZH18D□A-11-N03-13
 ZH18D□A-N03-N03-N03
 ZH20D□A-10-04-12
 ZH20D□A-03-04-04
 ZH20D□A-11-N04-13
 ZH20D□A-N03-N04-N04

The above shown products cannot be mounted closely together, as width across flats of the screw-in connection will interfere with each other.

L-Bracket (Brackets on Both Sides)

Part no.	Applicable model	A	B	C	D	E	F	G	H	J	K	L	t
AS-10L	ZH05/07/10D□A	11	14.8	18.3	3.4	27.5	19.5	3.4	4.9	7.3	12	14	1
AS-25L	ZH13/15D□A	17	19.6	24.6	4.5	38	28	4.5	6.5	9.5	15.5	20	1.2
AS-30L	ZH18/20D□A	22	24.8	29.8		43	33					22	1.4

Body Ported: ZH05D^SA-□-□-□ to ZH20D^SA-□-□-□

DIN rail mounting bracket (Bracket on a single side)*

ZH05 to 10D□A

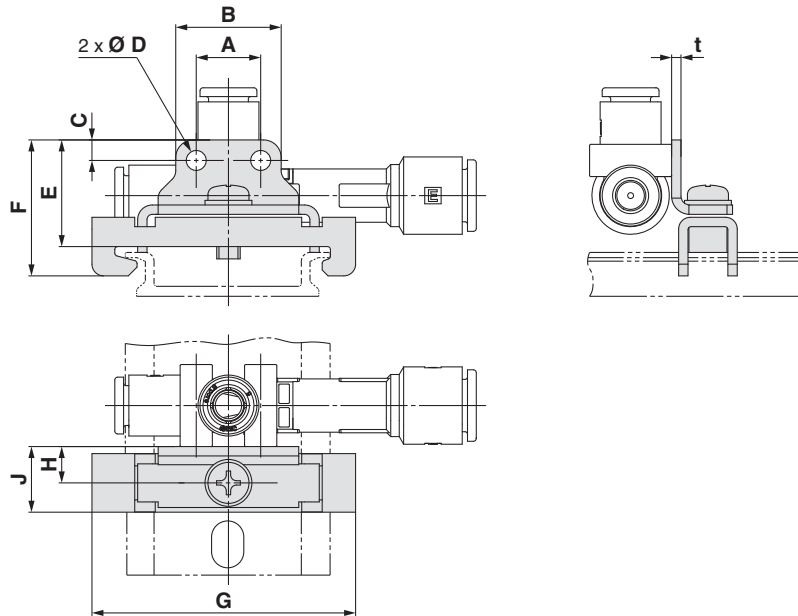

ZH13 to 20D□A

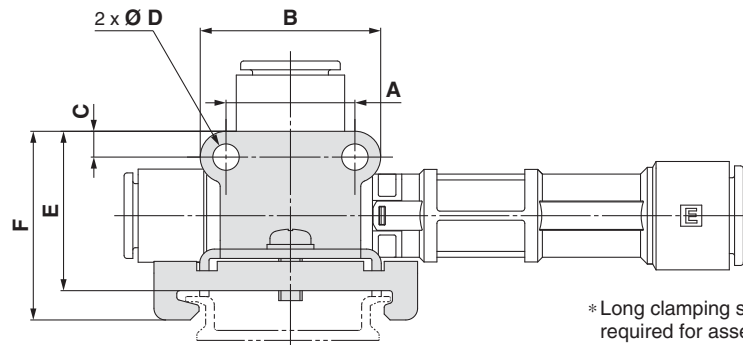

* Long clamping screw set for 1 station required for assembly needs to be ordered separately. Refer to page 3.

DIN rail mounting bracket (Brackets on both sides)*

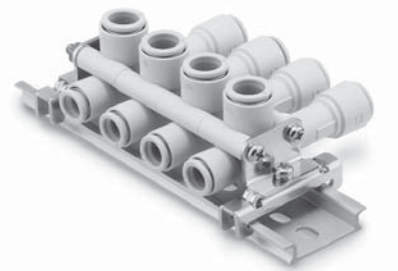
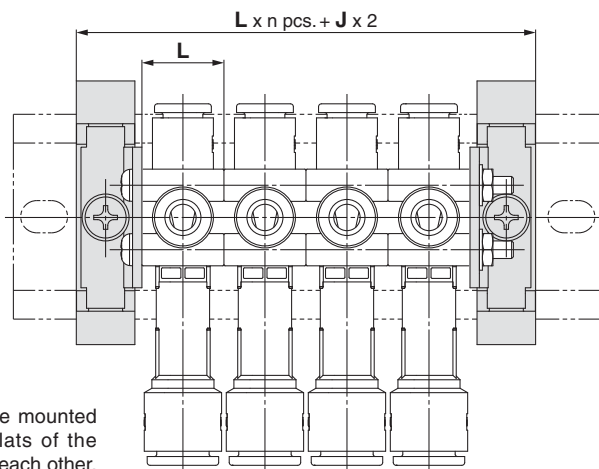

- *ZH15D□A-09-N03-11
- ZH15D□A-N02-N03-N03
- ZH18D□A-11-N03-13
- ZH18D□A-N03-N03-N03
- ZH20D□A-10-04-12
- ZH20D□A-03-04-04
- ZH20D□A-11-N04-13
- ZH20D□A-N03-N04-N04

The above shown products cannot be mounted closely together, as width across flats of the screw-in connection will interfere with each other.

* Long clamping screw set which is required for assembly needs to be ordered separately. Refer to page 3.

DIN Rail Mounting Bracket (Brackets on Both Sides)

Part no.	Applicable model	A	B	C	D	E	F	G	H	J	L	t
AS-10D	ZH05/07/10D□A	11	18	3.5	3.4	18.2	23.2	45	6.2	11.2	14	1.6
AS-25D	ZH13/15D□A	17	25.8	4.4	4.5	22	27				20	
AS-30D	ZH18/20D□A	22	30.8			27.2	32.2				22	

Series ZH Circuit Examples

⚠ Caution

Handling of Circuits

Select the related air preparation equipment with applicable size in reference to the circuit example below.

Ex. 1 Supply valve (2 port valve) + Suction filter

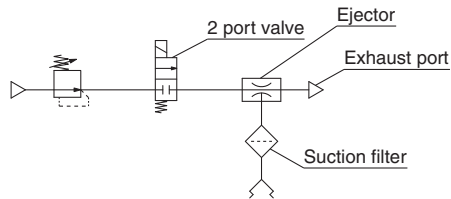

2 port valve is used to generate and stop the vacuum. Vacuum is released to the atmosphere. A suction filter is installed to protect the ejector.

Ex. 2 Supply valve (3 port valve) + Variable throttle + Suction filter

3 port valve is used to generate and release the vacuum.

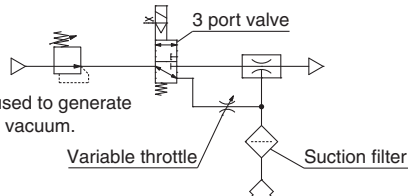

3 port valve is used to generate and stop the vacuum (vacuum release is performed simultaneously). Variable throttle is installed for break flow adjustment. A suction filter is protecting the ejector.

Ex. 3 Supply valve (3 port valve) + Variable throttle + Suction filter + Silencer

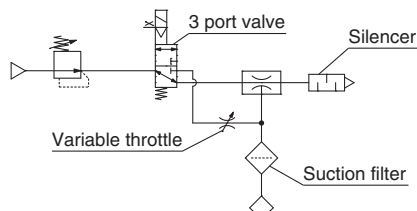

Power failure is prevented by changing the valve piping of Ex.2 and applying vacuum generation N.O. specification. Variable throttle and suction filters are installed. A silencer is mounted to the exhaust port (to reduce exhaust noise).

Ex. 4 Supply valve (2 port valve) + Release valve (2 port valve) + Variable throttle + Silencer + Suction filter + Pressure gauge

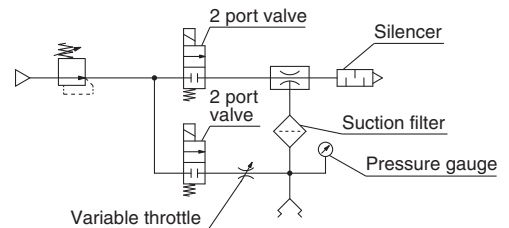

Vacuum generation and vacuum release are controlled by supply valve and release valve. A pressure gauge is installed to visually check the vacuum pressure during adsorption. The suction filter should be mounted to the location where the collected dust should not flow back due to release of air. (When using the 3 port valve, seal the R port of the release valve.)

Ex. 5 Supply/Release valve (5 port valve with 3-position) + Variable throttle

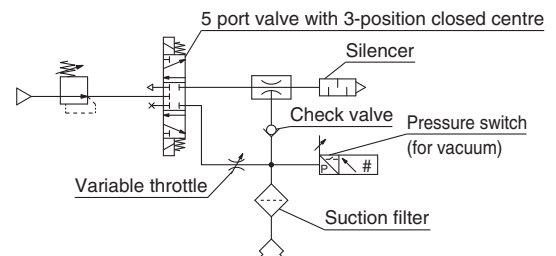

5 port valve with 3-position closed centre is used to control the vacuum generation and release. A check valve is installed to the vacuum port to prevent vacuum pressure from being reduced when the supply valve is OFF. A pressure switch is installed in the vacuum circuit to detect pressure. A suction filter should be mounted to the position where the duct collected by release air can be flushed by released air.

*The vacuum may leak depending on the check valve used. If a breathable workpiece is used, vacuum pressure is reduced rapidly. Sufficient verification is required before use.



Series ZH Specific Product Precautions 1

Be sure to read this before handling. Refer to the back cover for Safety Instructions. For Vacuum Equipment Precautions, refer to "Handling Precautions for SMC Products" and the Operation Manual on the SMC website, <http://www.smc.eu>

Mounting

⚠ Caution

1. Load to the ejector body

The body material is resin, therefore do not apply load to the port after mounting. Prevent the operation which generates moment, as it may cause performance reduction or damage to the body.

2. Standard bracket

It is possible to mount and remove the standard bracket, which is included with this product (option without bracket can be selected). Do not excessively expand or bend the bracket as it may break. The appropriate tightening torque for the standard bracket is shown below.

For M3: 0.315 ± 0.03 N·m

For M4: 0.76 ± 0.08 N·m

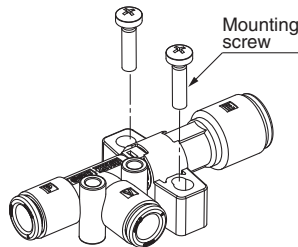

● Mounting of standard bracket (ZH05 to 10D□A) and adjustment of vacuum (V) port

- 1) Align the recess of the bracket and protrusion of the adapter. Push the bracket from the top onto adapter (Fig.1).
- 2) Adjust the adapter to rotate the vacuum (V) port (Fig.2).

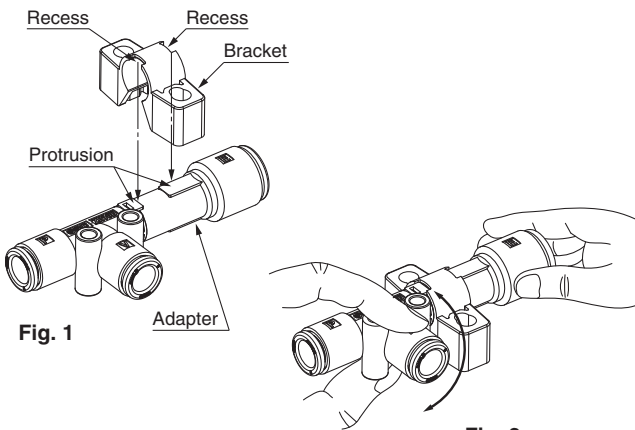
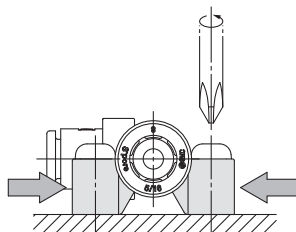

Fig. 1

Fig. 2

- 3) When mounting the product with a standard bracket, tighten the screw while holding both sides of the bracket. If the fit of the bracket is loose, the ejector may move after tightening the screws.



⚠ Caution

● Mounting of standard bracket (ZH18/20D□A) and adjustment of vacuum (V) port

- 1) The standard bracket of ZH18/20D□A can be mounted either by using mounting holes 1 or 2 (Fig.3).
- 2) When mounting the product through mounting hole 1, mount the bracket to the installation position first (Fig.3).
- 3) To mount the product to the bracket, push it down while directing the narrow rib and E mark on the adapter upward and the wider rib to the side (Fig.4). Hold the adapter when rotating the vacuum (V) port for adjustment.
- 4) To remove the body from the bracket, unclip the fingers (2 pcs.) on one side outside and pull the ejector up while rotating the adapter. If the ejector is pulled up without unclipping the fingers, it may damage the bracket (Fig.5, 6). If an increased holding force is required, please contact your SMC sales representative.

Bracket for ZH18/20D□A

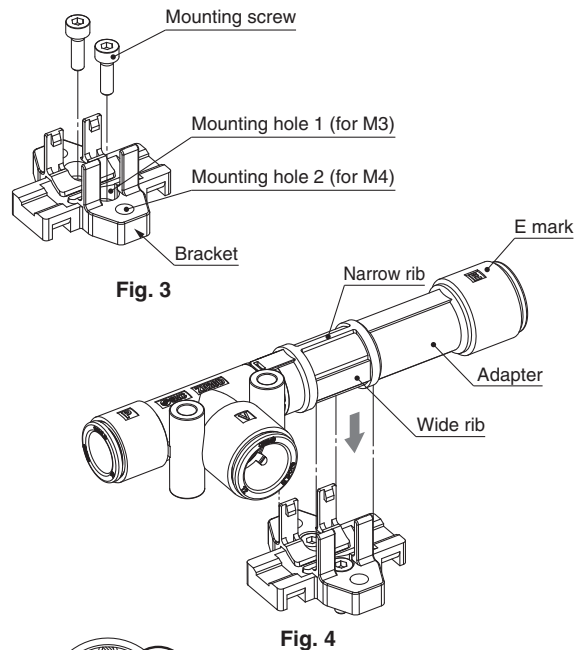

Fig. 3

Fig. 4

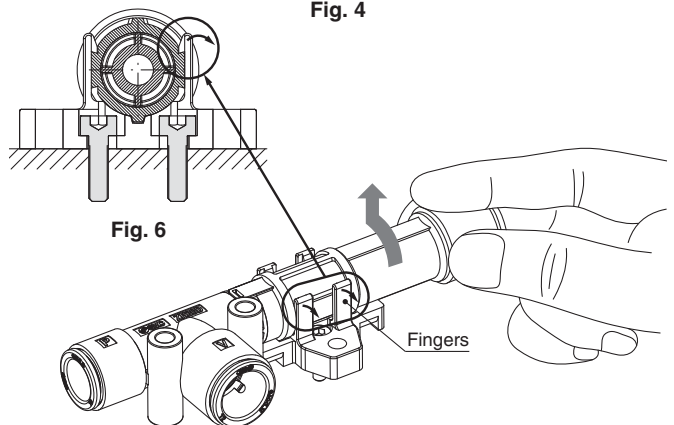

Fig. 6

Fig. 5



Series ZH Specific Product Precautions 2

Be sure to read this before handling. Refer to the back cover for Safety Instructions. For Vacuum Equipment Precautions, refer to “Handling Precautions for SMC Products” and the Operation Manual on the SMC website, <http://www.smc.eu>

Mounting

⚠ Caution

● Precautions for mounting with body mounting holes

If models listed below are intended to be mounted on a plane surface through the body mounting holes, the outside diameter of the screw-in stud will interfere with the mounting surface. Therefore, use a spacer with a thickness 1 or above.

Applicable model	t
ZH15D□A-09-N03-11 ZH15D□A-N02-N03-N03	2
ZH18D□A-11-N03-13 ZH18D□A-N03-N03-N03	1
ZH20D□A-10-04-12	
ZH20D□A-03-04-04	
ZH20D□A-11-N04-13 ZH20D□A-N03-N04-N04	

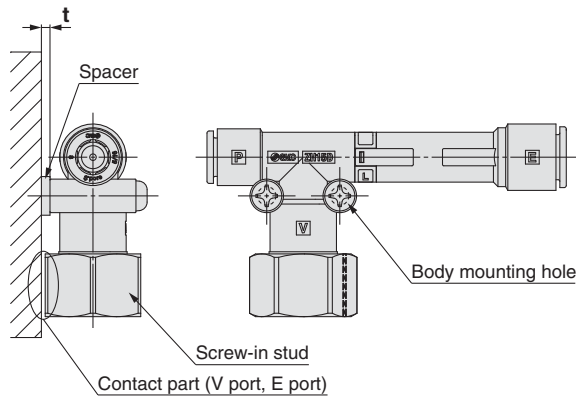

Piping

⚠ Caution

1. Piping diameter

The piping diameter for each port should be the standard size of One-touch fitting. If the piping diameter is reduced, it may lead to insufficient flow of supply air, reduction of suction flow and reduction in the vacuum pressure.

2. Exhaust port piping

If there is any piping or silencer connected to the exhaust port, keep the back pressure at 5 kPa or less. Increased back pressure may lead to reduction of suction flow and delay in the transport cycle time. If a silencer is connected, the specified vacuum performance is reduced by 10 % or less.

3. One-touch fittings

Refer to the one-touch fittings catalogue for more details about their piping and mounting precautions.

4. Piping to the female thread type

When mounting a fitting to the screw-in stud (female thread), hold the width across flats with an appropriate size wrench. If the load is applied to the resin body directly, it may damage the body.

Model Selection

⚠ Caution

1. Supply valve

Select the supply valve which can supply sufficient flow rate compared with the ejector air consumption. If the flow rate of the supply valve is insufficient, it may lead to vacuum failure. The selected supply valve should at least have the C factor shown in the table below.

Minimum C Factor of a Supply Valve

Model	C[dm ³ /(s·bar)]
ZH05□□A	0.12
ZH07□□A	0.23
ZH10□□A	0.47
ZH13□□A	0.80
ZH15□□A	1.06
ZH18□□A	1.53
ZH20□□A	1.88

2. Mounting of air equipment

If particles are sucked through the vacuum (V) port during workpiece adsorption, the vacuum performance might be reduced due to adhesion of particles to air passage of the product or clogging of the exhaust passage (silencer). It is recommended to install an air suction filter (ZFA, ZFB, ZFC series) in the middle of the piping on the vacuum side to prevent performance reduction. If air containing moisture is sucked, vacuum performance might also be reduced due to the same reason. In this case, install a drain separator for vacuum (AMJ series).

Air Supply

⚠ Caution

1. Quality of supply air

The compressed air supplied to the product should be cleaned in order to achieve the following impurity content recommendation based on the grade of compressed air quality 2.4.3, 2.5.3 and 2.6.3 of ISO8573-1: 2010 (JIS B8392-1: 2012). If impurity enters the product, vacuum performance might be reduced due to deterioration of air passage and clogging of exhaust system.



Series ZH Specific Product Precautions 3

Be sure to read this before handling. Refer to the back cover for Safety Instructions. For Vacuum Equipment Precautions, refer to “Handling Precautions for SMC Products” and the Operation Manual on the SMC website, <http://www.smc.eu>

Ejector Characteristics

Caution

1. Intermittent noise during vacuum generation

When the ejector standard supply pressure is close to the pressure that generates peak vacuum pressure, vacuum pressure may become unstable due to fluid vibration. If there is any operation failure or the intermittent noise needs to be reduced, increase or decrease the supply pressure. Avoid the supply pressure range where the vacuum pressure becomes unstable.

2. Temperature reduction and vapour condensation during vacuum generation

When the ejector generates vacuum, compressed air expands adiabatically after passing through the nozzle. The temperature around the nozzle is reduced, so condensation might be generated on the product surface (the condensation dew point may vary depending on the temperature and relative humidity of the operating environment).

When Ejector Operates

Caution

1. Exhaust air



If solid substances are sucked in through the vacuum (V) port, they will be discharged from the exhaust port with high speed, if the exhaust (EXH.) port is opened. Therefore, do not look into the exhaust port and direct the exhaust port toward a person when the ejector is operating.

2. Exhaust noise

Models with large nozzle diameter generate a large exhaust noise if the exhaust (EXH.) port is opened. Install a piping or silencer to the exhaust port to reduce the exhaust noise.

Safety Instructions

These safety instructions are intended to prevent hazardous situations and/or equipment damage. These instructions indicate the level of potential hazard with the labels of “Caution,” “Warning” or “Danger.” They are all important notes for safety and must be followed in addition to International Standards (ISO/IEC)*1), and other safety regulations.

-  **Caution:** Caution indicates a hazard with a low level of risk which, if not avoided, could result in minor or moderate injury.
-  **Warning:** Warning indicates a hazard with a medium level of risk which, if not avoided, could result in death or serious injury.
-  **Danger:** Danger indicates a hazard with a high level of risk which, if not avoided, will result in death or serious injury.

- *1) ISO 4414: Pneumatic fluid power – General rules relating to systems.
- ISO 4413: Hydraulic fluid power – General rules relating to systems.
- IEC 60204-1: Safety of machinery – Electrical equipment of machines.
(Part 1: General requirements)
- ISO 10218-1: Manipulating industrial robots - Safety.
etc.

Warning

- The compatibility of the product is the responsibility of the person who designs the equipment or decides its specifications.**
Since the product specified here is used under various operating conditions, its compatibility with specific equipment must be decided by the person who designs the equipment or decides its specifications based on necessary analysis and test results. The expected performance and safety assurance of the equipment will be the responsibility of the person who has determined its compatibility with the product. This person should also continuously review all specifications of the product referring to its latest catalogue information, with a view to giving due consideration to any possibility of equipment failure when configuring the equipment.
- Only personnel with appropriate training should operate machinery and equipment.**
The product specified here may become unsafe if handled incorrectly. The assembly, operation and maintenance of machines or equipment including our products must be performed by an operator who is appropriately trained and experienced.
- Do not service or attempt to remove product and machinery/equipment until safety is confirmed.**
 - The inspection and maintenance of machinery/equipment should only be performed after measures to prevent falling or runaway of the driven objects have been confirmed.
 - When the product is to be removed, confirm that the safety measures as mentioned above are implemented and the power from any appropriate source is cut, and read and understand the specific product precautions of all relevant products carefully.
 - Before machinery/equipment is restarted, take measures to prevent unexpected operation and malfunction.
- Contact SMC beforehand and take special consideration of safety measures if the product is to be used in any of the following conditions.**
 - Conditions and environments outside of the given specifications, or use outdoors or in a place exposed to direct sunlight.
 - Installation on equipment in conjunction with atomic energy, railways, air navigation, space, shipping, vehicles, military, medical treatment, combustion and recreation, or equipment in contact with food and beverages, emergency stop circuits, clutch and brake circuits in press applications, safety equipment or other applications unsuitable for the standard specifications described in the product catalogue.
 - An application which could have negative effects on people, property, or animals requiring special safety analysis.
 - Use in an interlock circuit, which requires the provision of double interlock for possible failure by using a mechanical protective function, and periodical checks to confirm proper operation.

Limited warranty and Disclaimer/ Compliance Requirements

The product used is subject to the following “Limited warranty and Disclaimer” and “Compliance Requirements”.
Read and accept them before using the product.

Limited warranty and Disclaimer

- The warranty period of the product is 1 year in service or 1.5 years after the product is delivered, whichever is first.*2)
Also, the product may have specified durability, running distance or replacement parts. Please consult your nearest sales branch.
- For any failure or damage reported within the warranty period which is clearly our responsibility, a replacement product or necessary parts will be provided. This limited warranty applies only to our product independently, and not to any other damage incurred due to the failure of the product.
- Prior to using SMC products, please read and understand the warranty terms and disclaimers noted in the specified catalogue for the particular products.

*2) Vacuum pads are excluded from this 1 year warranty.

A vacuum pad is a consumable part, so it is warranted for a year after it is delivered. Also, even within the warranty period, the wear of a product due to the use of the vacuum pad or failure due to the deterioration of rubber material are not covered by the limited warranty.

Caution

- The product is provided for use in manufacturing industries.**
The product herein described is basically provided for peaceful use in manufacturing industries.
If considering using the product in other industries, consult SMC beforehand and exchange specifications or a contract if necessary.
If anything is unclear, contact your nearest sales branch.

Caution

- SMC products are not intended for use as instruments for legal metrology.**
Measurement instruments that SMC manufactures or sells have not been qualified by type approval tests relevant to the metrology (measurement) laws of each country. Therefore, SMC products cannot be used for business or certification ordained by the metrology (measurement) laws of each country.

Safety Instructions

Be sure to read “Handling Precautions for SMC Products” (M-E03-3) before using.

SMC Corporation (Europe)

Austria	☎ +43 (0)2262622800	www.smc.at	office@smc.at	Lithuania	☎ +370 5 2308118	www.smclt.lt	info@smclt.lt
Belgium	☎ +32 (0)33551464	www.smcpnautics.be	info@smcpneautics.be	Netherlands	☎ +31 (0)205318888	www.smcpnautics.nl	info@smcpneautics.nl
Bulgaria	☎ +359 (0)2807670	www.smc.bg	office@smc.bg	Norway	☎ +47 67129020	www.smc-norge.no	post@smc-norge.no
Croatia	☎ +385 (0)13707288	www.smc.hr	office@smc.hr	Poland	☎ +48 222119600	www.smc.pl	office@smc.pl
Czech Republic	☎ +420 541424611	www.smc.cz	office@smc.cz	Portugal	☎ +351 226166570	www.smc.eu	postpt@smc.smces.es
Denmark	☎ +45 70252900	www.smcdk.com	smc@smcdk.com	Romania	☎ +40 213205111	www.smcromania.ro	smcromania@smcromania.ro
Estonia	☎ +372 6510370	www.smcpnautics.ee	smc@smcpneautics.ee	Russia	☎ +7 8127185445	www.smc-pneumatik.ru	info@smc-pneumatik.ru
Finland	☎ +358 207513513	www.smc.fi	smc@smc.fi	Slovakia	☎ +421 (0)413213212	www.smc.sk	office@smc.sk
France	☎ +33 (0)164761000	www.smc-france.fr	info@smc-france.fr	Slovenia	☎ +386 (0)73885412	www.smc.si	office@smc.si
Germany	☎ +49 (0)61034020	www.smc.de	info@smc.de	Spain	☎ +34 902184100	www.smc.eu	post@smc.smces.es
Greece	☎ +30 210 2717265	www.smchellas.gr	sales@smchellas.gr	Sweden	☎ +46 (0)86031200	www.smc.nu	post@smc.nu
Hungary	☎ +36 23511390	www.smc.hu	office@smc.hu	Switzerland	☎ +41 (0)523963131	www.smc.ch	info@smc.ch
Ireland	☎ +353 (0)14039000	www.smcpnautics.ie	sales@smcpneautics.ie	Turkey	☎ +90 212 489 0 440	www.smcpnomatik.com.tr	info@smcpnomatik.com.tr
Italy	☎ +39 0292711	www.smcitalia.it	mailbox@smcitalia.it	UK	☎ +44 (0)845 121 5122	www.smcpnautics.co.uk	sales@smcpneautics.co.uk
Latvia	☎ +371 67817700	www.smc.lv	info@smclv.lv				

SMC CORPORATION Akihbara UDX 15F, 4-14-1, Sotokanda, Chiyoda-ku, Tokyo 101-0021, JAPAN Phone: 03-5207-8249 FAX: 03-5298-5362