

## VHS20/30/40/50, Pressure Relief 3 Port Valve w/Locking Holes (Single Action)

VHS30-03A

### Data Sheet

The VHS Series is the latest product to benefit from a design review as part of our investment in R&D to improve the performance and functionality of SMC products, as well as to develop innovations that drive energy savings and deliver competitive advantages for our customers. A result of this focus, the updated VHS features an increased flow rate of up to 45%, which means it can be used for larger applications, offering commercial benefits as customers don't have to pay for bigger and therefore, more costly valves. The new VHS Series also has two material options for the handle and bonnet; PBT resin and aluminium. The PBT resin is highly flame resistant and up to 60% lighter than the conventional all-aluminium model. Furthermore, the double action model, which prevents malfunctions, is available in two new sizes, the VHS2510 and VHS3510. Other new features include a built-in silencer to save space in the area below the valve and the mounting bracket. All this is combined with an improved look to complement the new air preparation AC Series.

## Standard Specifications

Body Size	30
Thread	Rc
Port Size	3/8
Handle/Bonnet Material	Flame Resistant PBT
Options	None
Semi-standard	None
Made to Order	None
Pressure medium	Air
Maximal operating pressure	1.0 MPa
Minimum operating pressure	0.01 MPa
Proof pressure	1.5 MPa
Maximum ambient temperature	60 °C
Minimum ambient temperature	-5 °C (No freezing)
Conform to the European RoHS Directive	Conform
Approvals	No need
Paint colour	Handle: Red Body: White
Handle switching angle	90°
Weight	0.119 kg

## Dimensions

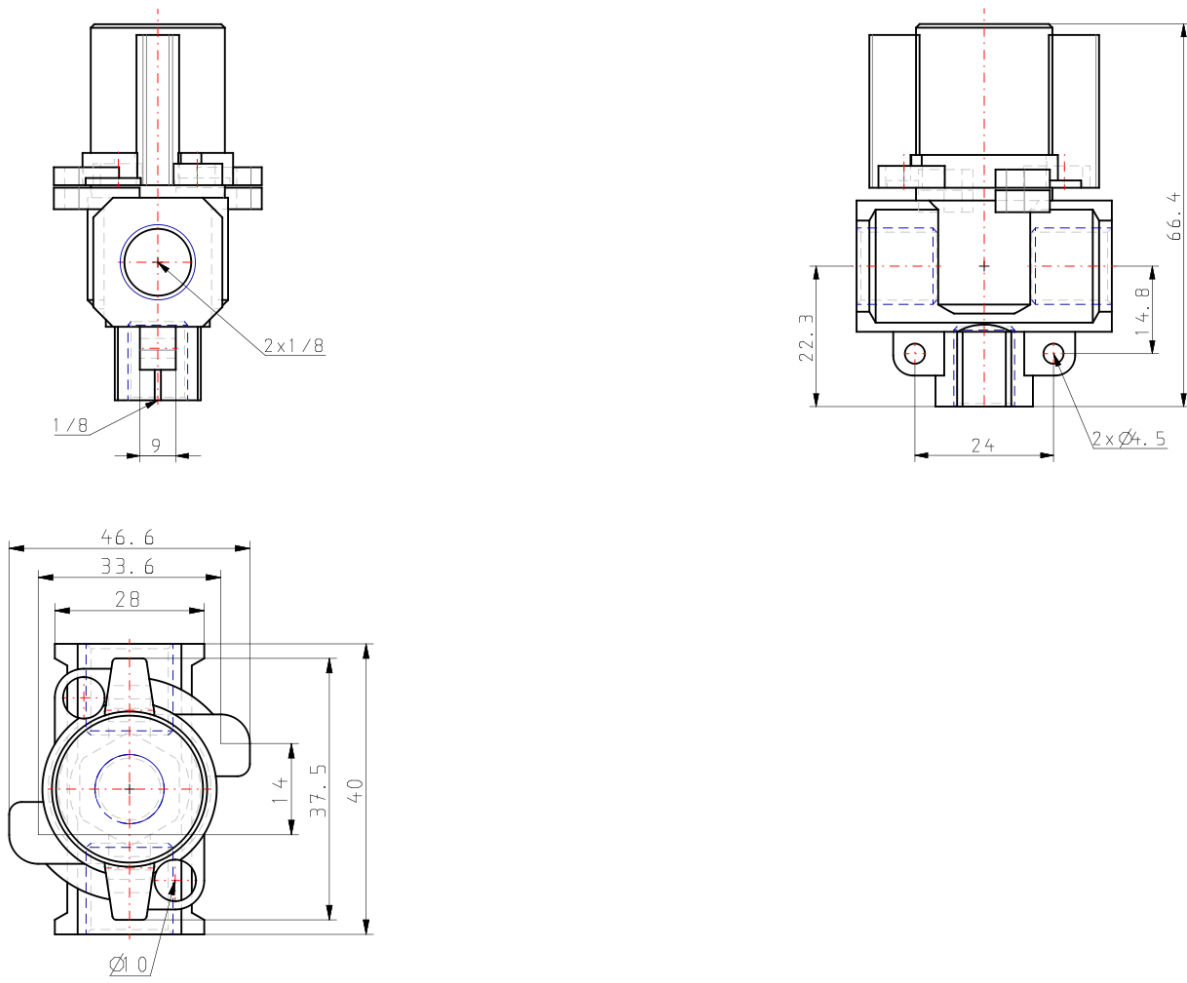

Specifications are subject to change without prior notice and any obligation on the part of the manufacturer.

# Constructions

## Construction

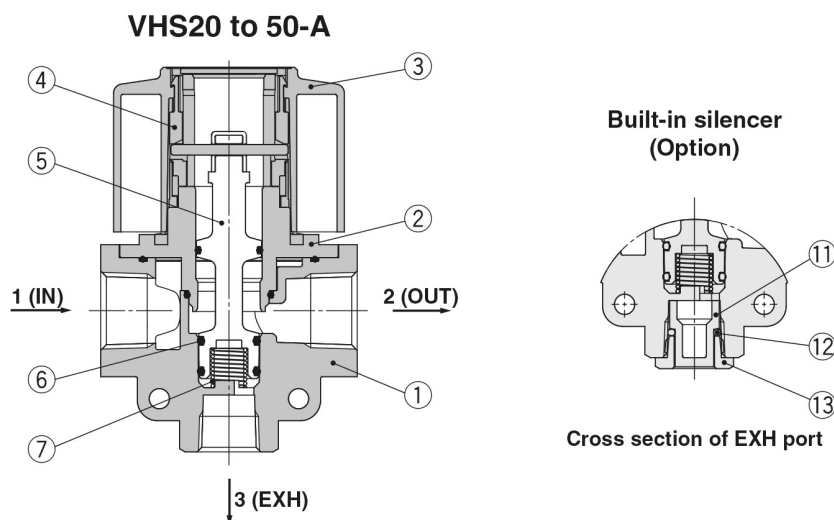

### Component Parts

No.	Description	Material		Note
		VHS20 to 50-A	VHS20 to 50-B	
1	<b>Body</b>	ADC12		White
2	<b>Bonnet</b>	Flame resistant PBT (UL-94 Standard V-0 equivalent)	ADC12	White
3	<b>Handle</b>	Flame resistant PBT (UL-94 Standard V-0 equivalent)	ADC12	Red
4	<b>Cam ring</b>	POM		—
5	<b>Spool</b>	PBT		—
6	<b>Spool O-ring</b>	H-NBR		—
7	<b>Spool spring</b>	Stainless steel		—
8	<b>Ferrule</b>	POM		—

\* The VHS series cannot be disassembled. Parts cannot be shipped separately.

### Option Part No.

Model	Bracket assembly part no. Note 1)	Silencer assembly part no. Note 2)
<b>VHS20</b>	VHS20PW-180AS	VHS20PW-190AS
<b>VHS30</b>	VHS30PW-180AS	VHS30PW-190AS
<b>VHS40</b>	VHS40PW-180AS	VHS40PW-190AS
<b>VHS40-06</b>	VHS40PW-180-06AS	VHS40PW-190-06AS
<b>VHS50</b>	VHS50PW-180AS	VHS50PW-190AS

Note 1) Bracket/1pc., mounting screw/2pcs.

Note 2) Element ①, element O-ring ②, element cover ③  
1pc. for each.

## Additional information

Catalogue

[VHS-A\\_EU.pdf](#)

Installation Manuals

[IM\\_VHS\\_SMU28EN.pdf](#)

## Related Products



AC-A



AC-B