

**CP96S(D), ISO 15552 Cylinder,  
Double Acting, Single/Double Rod  
with Air cushion on both ends and  
Bumper cushion  
CP96SDB40-50C**

**Data Sheet**

- CP96-C, ISO 15552 Cylinder, Double Acting, Single/Double Rod with Air Cushion and bumper.
- New types added: Standard for double rod, Non-rotating rod for double and single rod.
- Rod boot option added for the standard type.
- Integrated function of the air cushion and the bumper.
- Bore sizes (mm): 32 ~ 125.
- Strokes up to 2000 mm.
- Weight reduced by up to 15% thanks to the new the design of the cover and the piston.
- Many made to order available.

## Standard Specifications

Magnet	Built-in Magnet
Mounting	Basic
Bore Size	40mm
Stroke	50 mm
Rod Boot	w/o Rod Boot
Rod	Single Rod
Auto Switch	No Switch
Lead Wire or Prewired Connector	Or None in the Case of No Switch
Number	Or None in the Case of No Switch
Pressure medium	Compressed air
Maximum temperature of pressure medium	70 °C
Maximum temperature of pressure medium with magnet	60 °C
Minimum temperature of pressure medium	-20 °C (no freezing)
Minimum temperature of pressure medium with magnet	-10 °C (no freezing)
Maximal operating pressure	1.0 MPa
Minimum operating pressure	0.05 MPa
Proof pressure	1.5 MPa
Maximum ambient temperature	70 °C
Maximum ambient temperature with magnet	60 °C
Minimum ambient temperature	-20 °C (no freezing)
Minimum ambient temperature with magnet	-10 °C (no freezing)
XC7	Double-acting cylinder with cushioning adjustable at both ends, single piston rod
Number of pneumatic connections	2 pcs.
Pneumatic input connection	G 1/4
Pneumatic exhaust connection	G 1/4
XC6A	2059A_en.jpg
XC6B	Symbol43.jpg
Mode of operation of drive	Double acting
Theoretical cylinder force, advance stroke (at 0.5 MPa)	629 N
Theoretical cylinder force, return stroke (at 0.5 MPa)	528 N
Maximum piston speed	1,000 mm/s
Piston rod end	Male Thread
Malethread of rod end	M12 x 1.25
Tolerance of torsion	Air cushion on both ends + Bumper cushion
Usable tubing material	PU
Subfamily	CP96S(D), ISO 15552 Cylinder, Double Acting, Single/Double Rod with Air cushion on both ends and Bumper cushion
Weight	0.840 kg

# Dimensions

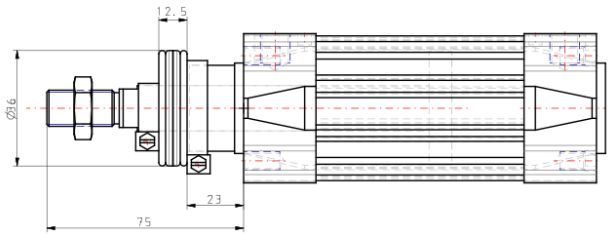
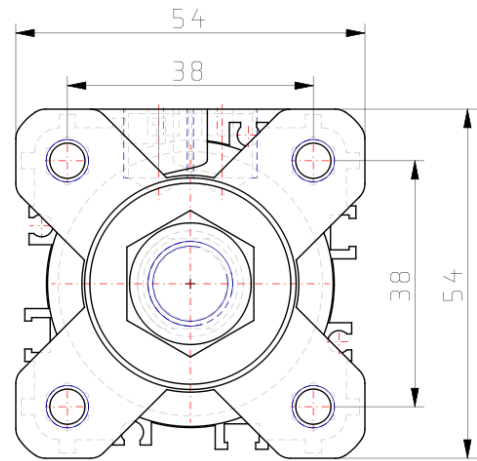
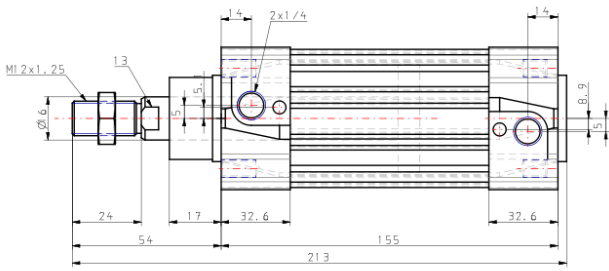

## Constructions

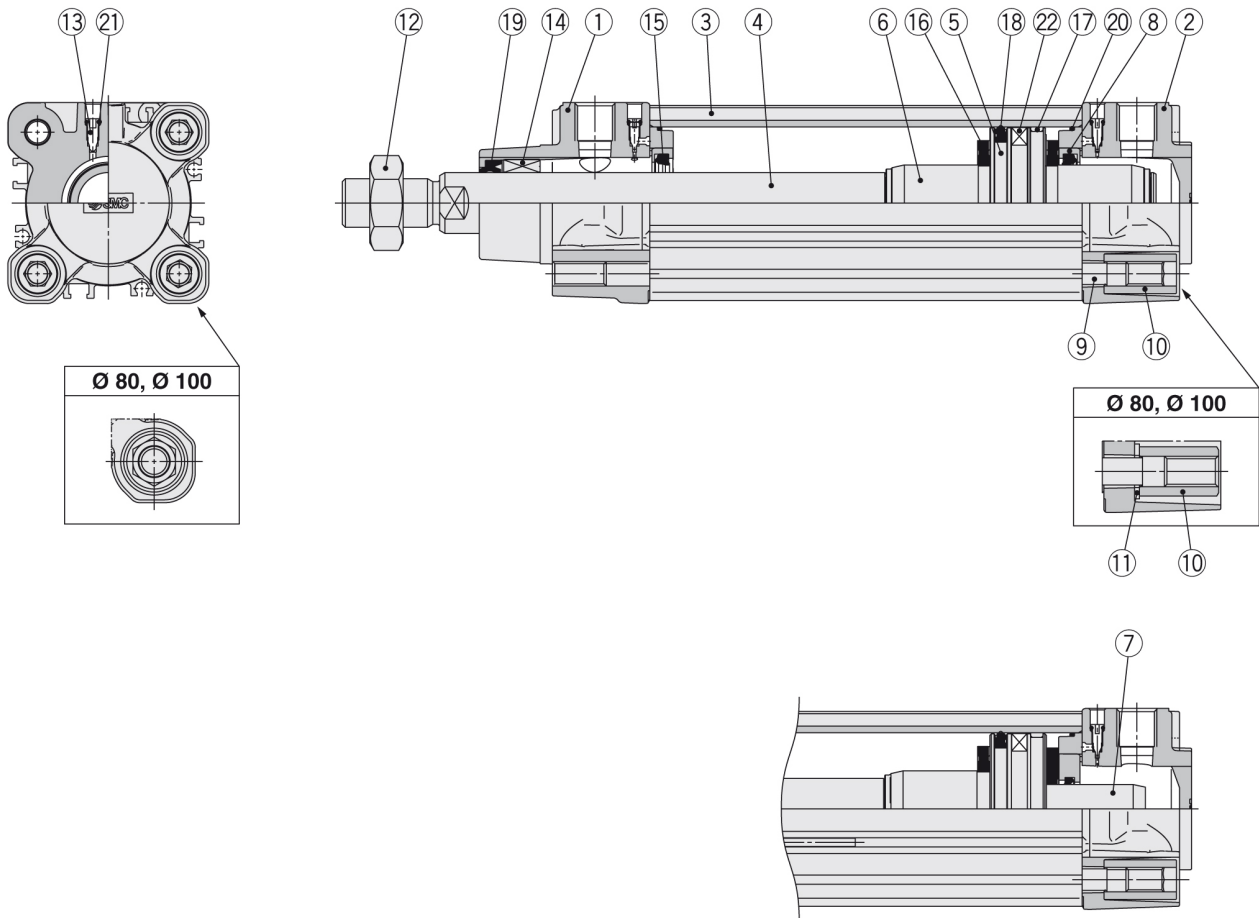

### Component Parts

No.	Description	Material	Note
1	Rod cover	Aluminium die-cast	
2	Head cover	Aluminium die-cast	
3	Cylinder tube	Aluminium alloy	
4	Piston rod	Carbon steel	
5	Piston	Aluminium alloy	Ø 32 to Ø 63
		Aluminium die-cast	Ø 80, Ø 100
6	Cushion ring A	Aluminium alloy	
7	Cushion ring B	Aluminium alloy	
8	Cushion seal holder	Aluminium alloy	
9	Tie-rod	Carbon steel	
10	Tie-rod nut	Steel	
11	Flat washer	Steel	Ø 80, Ø 100
12	Rod end nut	Steel	
13	Cushion valve	Resin	
14	Bushing	Bearing alloy	
15	Cushion seal	Urethane	
16	Bumper	Urethane	
17	Wear ring	Resin	
18	Piston seal	NBR	
19	Rod seal	NBR	
20	Cylinder tube gasket	NBR	
21	Cushion valve seal	NBR	
22	Magnet		

### Replacement Parts/Seal Kit (Single rod)

Bore size [mm]	Kit no.	Contents
32	CS95-32	Kits include items 15, 17 to 20.
40	CS95-40	
50	CS95-50	
63	CS95-63	
80	CS95-80	
100	CS96-100	

### Seal Kit (Double rod)

Bore size [mm]	Kit no.	Contents
32	CS95W-32	Kits include items 15, 18 to 20.
40	CS95W-40	
50	CS95W-50	
63	CS95W-63	
80	CS95W-80	
100	CS96W-100	

## Additional information

Catalogue

[CP96-Bb\\_EU.pdf](#)