

ASP, Speed Controller with Pilot Check Valve ASP530F-03-08S

Data Sheet

Series ASP is a speed controller with an integrated pilot check valve. This combination makes it possible to control cylinder speeds and permits temporary intermediate stops. The ASP is standard with electroless nickel plating on all brass parts and allows 360 degree freedom for tube mounting direction.

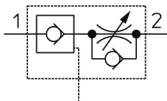

Speed controller with pilot check valve

Standard Specifications

Body Size	3/8 Basis
Port Size	R(PT) 3/8) Pilot Port (Rc(PT) 1/8
Applicable Tube OD	ø8
Made to Order	None
Lock Nut	Hexagon
Pressure medium	Compressed Air
Maximum temperature of pressure medium	60 °C
Minimum temperature of pressure medium	-5 °C
Maximal operating pressure	1 MPa
Minimum operating pressure	0.1 MPa
Proof pressure	1.5 MPa
Maximum ambient temperature	60 °C
Minimum ambient temperature	-5 °C
Function of Flow control valve	Meter-out
Flow rate	600 NI/min
Usable tubing material	Nylon, Soft nylon and Polyurethane tubing
Pilot check valve actuation pressure	50 % or more of operating pressure
Number of needle revolutions	10
Weight	0.107 kg

Dimensions

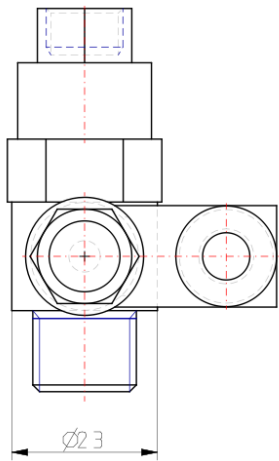
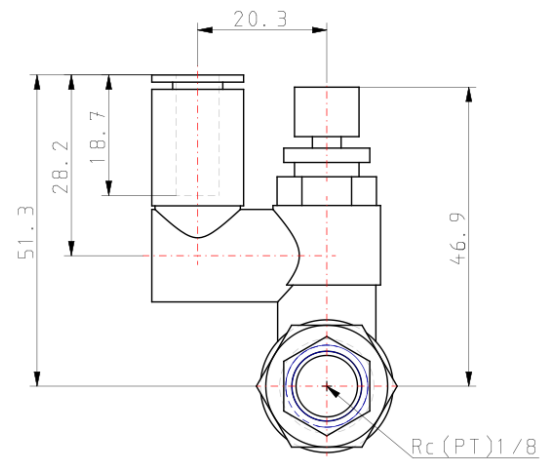
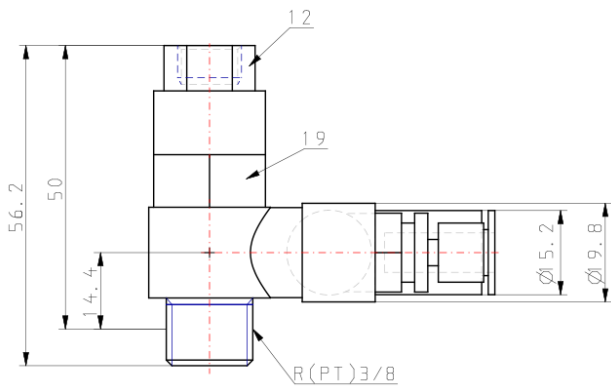

Constructions

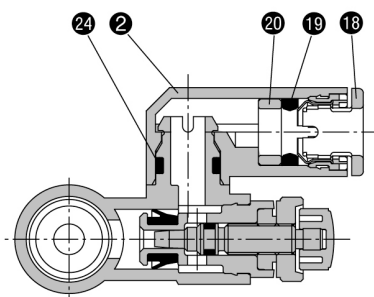
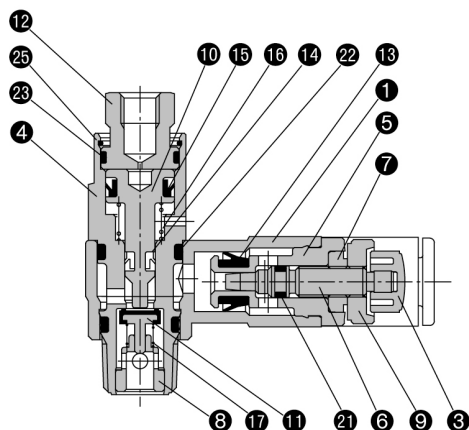

Parts list

No.	Description	Material	Note
1	Body A	PBT	
2	Elbow body	PBT	
3	Knob	PBT	
4	Pilot body	Brass	Electroless nickel plated
5	Body B	Brass	Electroless nickel plated
6	Needle	Brass	Electroless nickel plated
7	Needle guide	Brass	Electroless nickel plated
8	Guide	Brass	Electroless nickel plated
9	Lock nut	Brass	Electroless nickel plated
10	Piston	Brass	Electroless nickel plated
11	Valve	Stainless steel, NBR	
12	Cover	Brass	Black zinc chromated
13	U seal	NBR	

Parts list

No.	Description	Material	Note
14	DY seal	PBT	
15	DY seal	PBT	
16	Spring	Stainless steel	
17	Spring	Stainless steel	
18	Cassette	POM, Stainless steel ^{Note 1)}	
19	Seal	NBR	
20	Spacer	POM ^{Note 2)}	
21	O-ring	NBR	
22	O-ring	NBR	
23	O-ring	NBR	
24	O-ring	NBR	
25	Ring	Stainless steel	

Note 1) $\phi 10$, $\phi 12$, $\phi 3/8"$, $\phi 1/2"$ are POM, stainless steel and brass (electroless nickel plated).

Note 2) $\phi 1/4"$, $\phi 3/8"$, $\phi 1/2"$ are brass (electroless nickel plated).

Additional information

Catalogue

[AS_EU.pdf](#)

Installation Manuals

[IM_ASP_SMU62EN-A.pdf](#)