

# Color-Sensing Connected Components Building Block

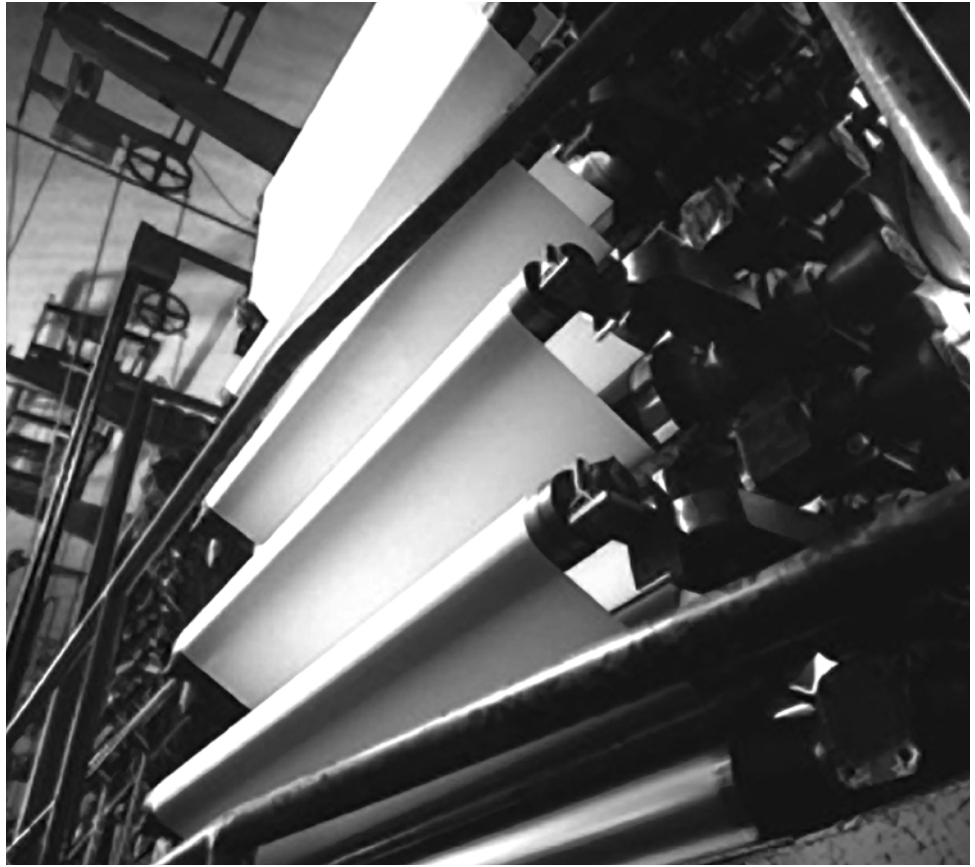

**Quick Start**

## Important User Information

Solid state equipment has operational characteristics differing from those of electromechanical equipment. Safety Guidelines for the Application, Installation and Maintenance of Solid State Controls (publication [SGI-1.1](#) available from your local Rockwell Automation sales office or online at <http://literature.rockwellautomation.com>) describes some important differences between solid state equipment and hard-wired electromechanical devices. Because of this difference, and also because of the wide variety of uses for solid state equipment, all persons responsible for applying this equipment must satisfy themselves that each intended application of this equipment is acceptable.





In no event will Rockwell Automation, Inc. be responsible or liable for indirect or consequential damages resulting from the use or application of this equipment.

The examples and diagrams in this manual are included solely for illustrative purposes. Because of the many variables and requirements associated with any particular installation, Rockwell Automation, Inc. cannot assume responsibility or liability for actual use based on the examples and diagrams.

No patent liability is assumed by Rockwell Automation, Inc. with respect to use of information, circuits, equipment, or software described in this manual.

Reproduction of the contents of this manual, in whole or in part, without written permission of Rockwell Automation, Inc., is prohibited.

Throughout this manual, when necessary, we use notes to make you aware of safety considerations.

|  |  |
|--|--|
| <b>WARNING</b><br>        | Identifies information about practices or circumstances that can cause an explosion in a hazardous environment, which may lead to personal injury or death, property damage, or economic loss.                               |
| <b>IMPORTANT</b>   | Identifies information that is critical for successful application and understanding of the product.   |
| <b>ATTENTION</b><br>    | Identifies information about practices or circumstances that can lead to personal injury or death, property damage, or economic loss. Attentions help you identify a hazard, avoid a hazard, and recognize the consequences. |
| <b>SHOCK HAZARD</b><br> | Labels may be on or inside the equipment, for example, a drive or motor, to alert people that dangerous voltage may be present.  |
| <b>BURN HAZARD</b><br>  | Labels may be on or inside the equipment, for example, a drive or motor, to alert people that surfaces may reach dangerous temperatures.   |

Rockwell Automation, Allen-Bradley, ColorSight, MicroLogix, PanelView, RSLogix, RSLogix 500, Stratix, and TechConnect, are trademarks of Rockwell Automation, Inc.

Trademarks not belonging to Rockwell Automation are property of their respective companies.

## Connected Components Building Block Outline

Follow the path below to complete your connected components building block.

Connected Components  
Building Blocks, publication  
[CC-QS001](#)

[Chapter 1 Product Integration](#)

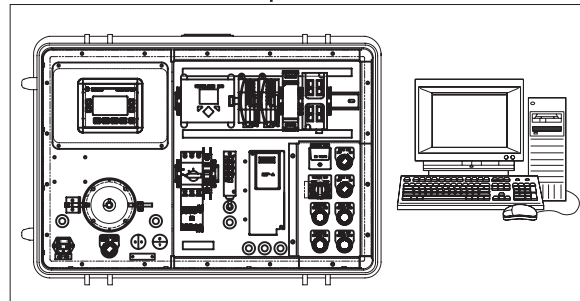

[Chapter 2 System Validation and Application Tips](#)

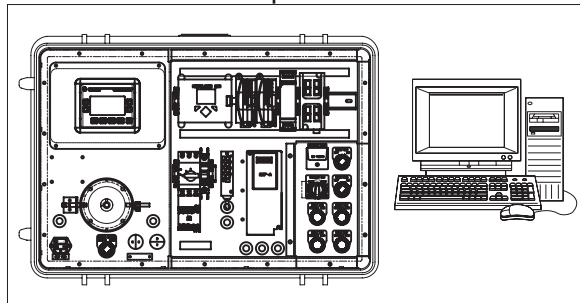

**Notes:**

## Preface

|                                |   |
|--------------------------------|---|
| Introduction . . . . .         | 7 |
| Conventions . . . . .          | 8 |
| Additional Resources . . . . . | 9 |

## Chapter 1

### Product Integration

|   |    |
|---|----|
| Introduction . . . . .                                    | 11 |
| Before You Begin . . . . .                                | 11 |
| What You Need . . . . .                                   | 11 |
| Follow These Steps . . . . .                              | 12 |
| Connect Components . . . . .                              | 13 |
| Configuring PanelView Component Terminal IP Addresses . . | 14 |

## Chapter 2

### System Validation and Application Tips

|   |    |
|---|----|
| Introduction . . . . .                            | 15 |
| Before You Begin . . . . .                        | 15 |
| What You Need . . . . .                           | 15 |
| Follow These Steps . . . . .                      | 16 |
| Overview of System Operation . . . . .            | 16 |
| Set Sensor Node Address and Baud Rate . . . . .   | 17 |
| Store and Read Sample Colors . . . . .            | 19 |
| Resetting the 45CLR to Factory Defaults . . . . . | 20 |

**Notes:**

## **Introduction**

This Quick Start demonstrates the setup and functionality of the 45CLR ColorSight sensor. In this application, when triggered, the MicroLogix controller reads the true color values from the sensor. The controller program then compares the red, green, and intensity values to high and low limits set by the user. When all the red, green, and intensity values are within the preset limits, an output is activated. This application has the ability to check five colors. If needed, this can be increased by adding additional rungs of ladder logic.

The application allows control of two sensors using two external triggers connected to the MicroLogix controller. These triggers are optional; the application will also work with a single 45CLR ColorSight sensor.

---

**IMPORTANT**

Use this Color-Sensing Connected Components Building Block Quick Start in conjunction with the Connected Components Building Blocks Quick Start, publication [CC-QS001](#).

Refer to [Additional Resources](#) on [page 9](#) for a listing of Quick Start documents.

---

To assist in the design and installation of your system, application files and other information are provided on the Connected Component Building Blocks Overview CD, publication CC-QR001. The CD provides bills of materials (BOM), CAD drawings for panel layout and wiring, control programs, Human Machine Interface (HMI) screens, and more. With these tools and the built-in best-practices design, the system designer is free to focus on the design of their machine control and not on design overhead tasks.

The beginning of each chapter contains the following information. Read these sections carefully before beginning work in each chapter:

- **Before You Begin** - This section lists the steps that must be completed and decisions that must be made before starting that chapter. The chapters in this quick start do not have to be completed in the order in which they appear, but this section defines the minimum amount of preparation required before completing the current chapter.
- **What You Need** - This section lists the tools that are required to complete the steps in the current chapter. This includes, but is not limited to, hardware and software.
- **Follow These Steps** - This illustrates the steps in the current chapter and identifies which steps are required to complete the examples.

## Conventions

This manual uses the following conventions.

| <b>Convention</b> | <b>Meaning</b>   | <b>Example</b>                           |
|-------------------|--|--|
| Check or uncheck  | To activate or deactivate a checkbox.                                | Check Disable Keying.                    |
| Click             | Click the left mouse button once.                                    | Click Browse.                            |
| Double-click      | Click the left mouse button twice in quick succession.               | Double-click the application icon.       |
| Expand            | Click the + to the left of a given item/folder to show its contents. | Expand 1768 Bus under I/O Configuration. |
| Right-click       | Click the right mouse button once.                                   | Right-click the 1768 Bus icon.           |
| Select            | Use the mouse to highlight a specific option.                        | Select the New Module folder.            |
| Enter             | What you type.   | Enter your choice.                       |
| Press             | Press a specific key on the keyboard.                                | Press Enter.                             |
| >                 | This symbol is used to indicate a sub-menu name.                     | Choose File>Menu>Options.                |



## Additional Resources

| Resource  | Description  |
|---|--|
| Connected Components Building Blocks Quick Start, publication <a href="#">CC-QS001</a>                                      | Provides information on how to select products and gain access to panel and wiring information.                    |
| Connected Component Building Blocks Overview CD, publication CC-QR001   | Provides files for the Connected Component Building Blocks.  |
| Installation Instructions 45CLR ColorSight (3 Output Channel Color Sensor), publication number <a href="#">10000007742</a>  | Provides information on the installation and operation of the 45CLR Colorsight sensor, including wiring and setup. |
| MicroLogix 1400 User Manual, publication <a href="#">1766-UM001</a>   | Provides information on using the MicroLogix 1400 programmable controller.   |
| PanelView Component HMI Terminals User Manual, publication <a href="#">2711C-UM001</a>                                      | Provides information on using the PanelView Component HMI Terminals.   |
| PHOTOSWITCH Photoelectronic Sensors, 45CLR ColorSight Color Sensor, publication <a href="#">45CLR-CA500A-EN-P</a>           | Provides information on installing the 45CLR ColorSight sensor including specifications and connector pinouts.     |
| <a href="http://www.ab.com">http://www.ab.com</a>   | Provides access to the Allen-Bradley website.  |
| <a href="http://rockwellautomation.com/knowledgebase">http://rockwellautomation.com/knowledgebase</a>                       | Provides access to self-service support.   |
| <a href="http://www.rockwellautomation.com/components/connected">http://www.rockwellautomation.com/components/connected</a> | Provides access to the Connected Components website.   |

## Notes:

# Product Integration

## Introduction

This chapter provides step-by-step instructions for wiring and configuring the 45CLR ColorSight sensor to communicate with the MicroLogix 1400 controller and PanelView Component terminal.

## Before You Begin

Review the Connected Components Building Blocks Quick Start, publication [CC-QS001](#), verifying that you have completed the hardware design and installation as well as software installation.

## What You Need

- Personal computer with RSLogix 500, RSLinx, and either Firefox v2.x or Internet Explorer 7.x software installed
- Connected Component Building Blocks Overview CD, publication CC-QR001
- This building block is designed for two ColorSight sensors and associated equipment. If you are using only one ColorSight sensor, only one of each of these is needed.
  - 45CLR ColorSight sensors (two (2)), catalog number 45CLR-5LPS1-D8
  - 8-pin DC Micro (M12) Cordsets (two (2)), catalog number 889D-F8AB-*x* (where *x* denotes the length of the cable, in meters) - for connection to 45 CLR ColorSight sensors.
  - Trigger Sensors (two (2)), catalog number 42CA-B2LPBE-DE
  - 4-pin DC Micro cables (two (2)), catalog number 889D-F4AC-2 - for connection to trigger sensors
- MicroLogix 1400 controller, catalog number 1766-L32BXB
- PanelView Component 600 terminal, catalog number 2711C -T6C
- Ethernet cables, catalog number 1585J-M8TBJM-2 or equivalent
- Stratix 2000 Ethernet switch, catalog number 1783-US05T (or equivalent) to connect your personal computer to the MicroLogix controller and the PanelView Component terminal
- RS485 to ML1400 communications cable, catalog number 1763-NC01
- Power supply, 100-120/220-240V AC input, 24-28V DC output, catalog number 1606-XLP30E

## Follow These Steps

Follow this step to wire the 45CLR ColorSight sensor to the power source and communication cable.

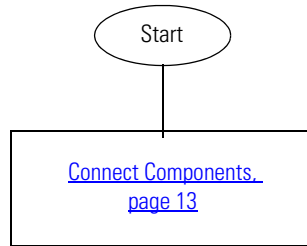

## Connect Components

To wire a 45CLR ColorSight sensor into the RS485 connection of the MicroLogix 1400 controller, perform the following steps.

1. Connect the 8-pin DC Micro cable, catalog number 889D-F8AB-x, to the 45CLR ColorSight sensor.
2. Connect 24V DC power and RS485 communications wiring according to the diagram below.

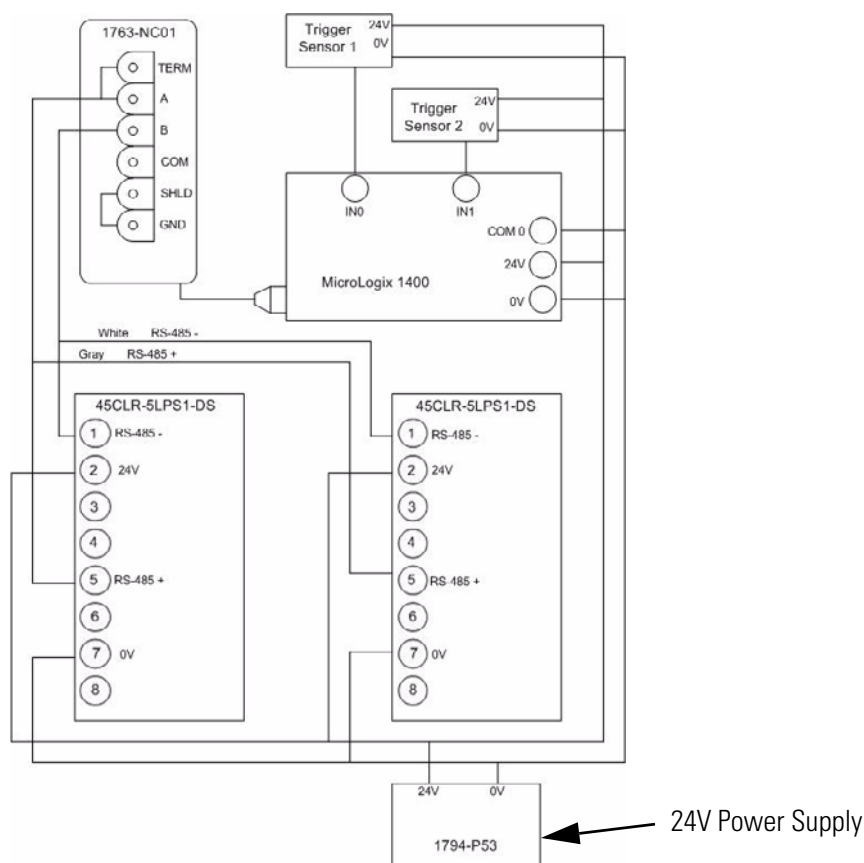

### TIP

The sample code and wiring diagram provided have been written to allow the control of two color sensors. If you are using only a single sensor, then wire only the 45CLR ColorSight sensor at Node 1 and Trigger sensor 1.

3. Make sure that the unused wires from the 8-pin DC Micro cable are insulated to be sure of correct system operation.
4. Energize the power supply.
5. Verify that the round white light on the sensor face of the 45CLR ColorSight sensor turns on.

## Configuring PanelView Component Terminal IP Addresses

In the Connected Components Building Blocks Quick Start, publication [CC-QS001](#), Chapter 3 - Controller and HMI Integration details how to set the Ethernet IP addresses in the MicroLogix 1400 controller and PanelView Component 600 terminal. If you have not done this already, follow those instructions to set the following static IP addresses in your devices.

- Set the personal computer IP address to 192.168.1.3.
- Set the PanelView Component terminal IP address to 192.168.1.4.
- Set the MicroLogix 1400 controller IP address to 192.168.1.2.
- Follow the instructions in the Load Your HMI Screens section of Chapter 3 to transfer your HMI screens to the PanelView Component Terminal.
- Follow the instructions in the Load Your Control Program section of Chapter 3 to transfer your control program to the MicroLogix controller for use in your application.

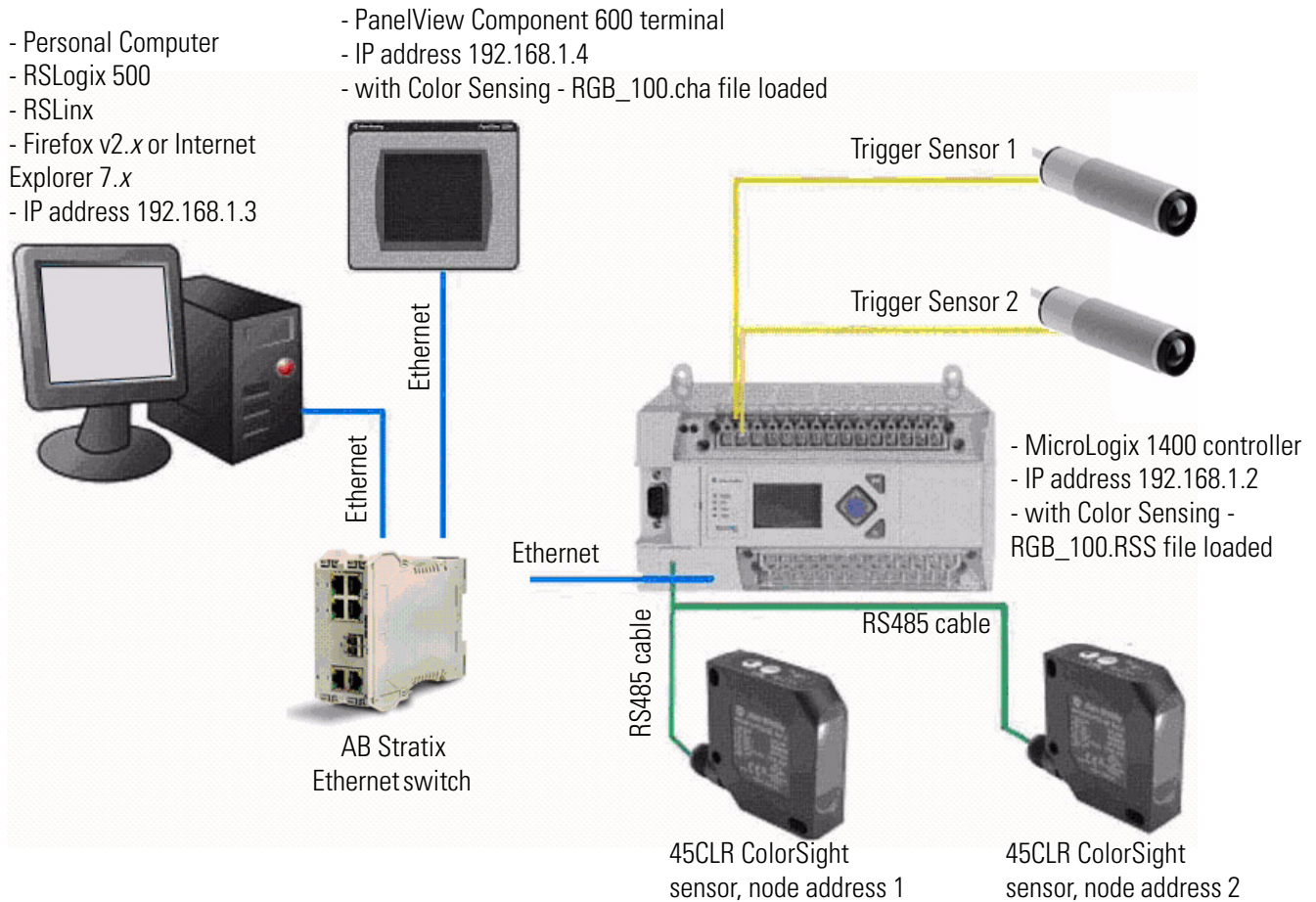

# System Validation and Application Tips

## Introduction

In this chapter, you will run and validate the operation of the 45CLR ColorSight sensor with the MicroLogix 1400 controller and PanelView Component terminal HMI.

## Before You Begin

- Verify that you have completed all the steps in [Chapter 1](#) of this document.
- Review the MicroLogix 1400 User Manual, publication [1766-UM001](#).
- Review PanelView Component HMI Terminals User Manual, publication [2711C-UM001](#).
- Review the PHOTOSWITCH Photoelectronic Sensors, 45CLR ColorSight Color Sensor, publication [45-CLR-CA500A-EN-P](#).
- Review the Installation Instructions 45CLR ColorSight (3 Output Channel Color Sensor), publication number [10000007742](#).
- Have equipment wired and set up per wiring and system overview diagrams in [Chapter 1](#) of this document.
- Be sure the system is powered off.

## What You Need

- Personal computer with RSLogix 500, RSLinx, and either Firefox v2.x or Internet Explorer 7.x software installed
- Connected Component Building Blocks Overview CD, publication CC-QR001
- PanelView Component 600 terminal, catalog number 2711C -T6C
- MicroLogix 1400 controller, catalog number 1766-L32BxB

## Follow These Steps

Follow these steps to verify that communication is occurring between your devices.

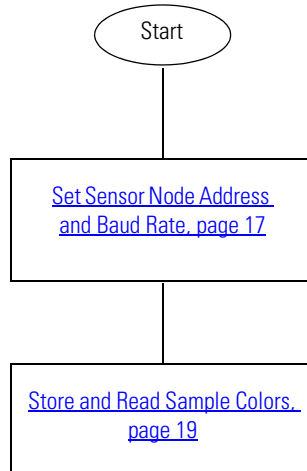

## Overview of System Operation

This application example allows you to read true red, green, and intensity values of a color read by the 45CLR ColorSight sensor and to use the HMI to set high and low limits for up to five colors in the controller. After triggering a read from the sensor, the controller checks the read values to determine if they fall within the limits previously stored. If the red, green, and intensity values for a single color all fall within the high and low limits for the color that has been read, the controller switches the corresponding output on.

The sample code provided in this application allows you to configure baud rate and node address of the sensor over the RS485 network and then save the settings within the sensor.

Once configured, each sensor can be controlled by entering its respective RGB screen from the HMI.



## Set Sensor Node Address and Baud Rate

45CLR ColorSight sensors are preconfigured at the factory for node address 1 at 9600 bps. When using multiple nodes on an RS485 network, it may be necessary to change a sensor's address or baud rate settings. In this application, there are two 45CLR ColorSight sensors, both of which have the default factory settings for node address 1. You will use the HMI to reset the address of the sensor intended to be at node address 2.

Follow these steps to modify the settings using the PanelView Component terminal HMI application.

1. With system power off, remove +24V DC from the sensor which is to use node address 1.
2. Apply power to the system to be reset to address 2.
3. Verify that the PanelView Component terminal, MicroLogix 1400 controller, and the 45CLR ColorSight sensor are powered up. The MicroLogix 1400 controller Run LED is on. The 45CLR ColorSight sensor will have a white circle of light in the detection area.

With the default setting of node address 1, the system considers the sensor to be sensor 1.

Perform the remainder of the steps in this section on the PanelView Component 600 terminal using the Network Overview screen.

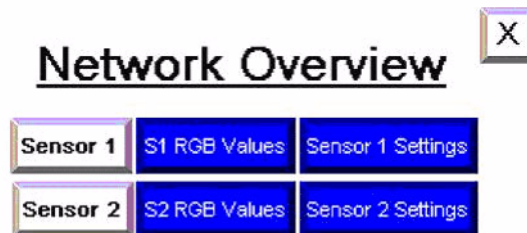

4. Touch Sensor 1 to activate Sensor 1.
5. Touch Sensor 1 Settings.

The sensor configuration screen is shown similar to this.

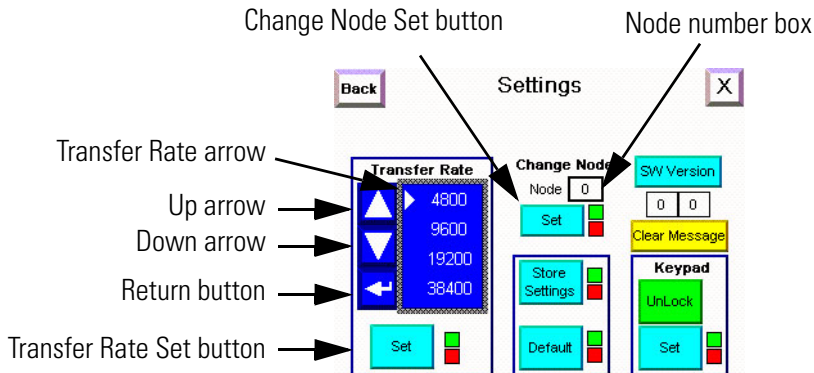

6. Using the up and down arrows, position the Transfer Rate arrow next to 9600 (baud rate).
7. Touch the Return button.
8. Touch the Transfer Rate Set button to set the baud rate to 9600.

The green box next to the Change Node Set button should be present. If the red box is present, then the command was not properly executed. If the green box is not present, confirm the system is wired correctly and reset the sensor to factory defaults per instructions in Resetting the 45CLR to Factory Defaults, page 20.

9. Touch the node number box.

A numeric pad will appear.

10. Touch the node number to which you want to set this sensor.

In this example, the node number must be node address 2.

11. Touch the Return button and then the Set button.

The green box next to the Change Node Set button should be present. If the red box is present, the command was not properly executed.

12. Touch the Store Settings button.

This stores the settings to the sensor. You should see a green box next to the Transfer Rate Set button and the Store Settings buttons. This indicates the sensor node was set and the setting stored in the sensor. If the box is red, then the settings were not accepted.

If there are no boxes present, then the 45CLR ColorSight sensor is not communicating with the MicroLogix 1400 controller.

13. Power off the system and reconnect +24V DC to the other 45CLR ColorSight sensor.

You will leave this sensor at the default Node address of 1.

The 45CLR ColorSight sensors and the MicroLogix 1400 controller are now set up for operation.

## Store and Read Sample Colors

1. On the PanelView Component terminal Network Overview screen, touch Sensor 1 and then touch S1 RGB Values.

The screen below appears for sensor values for either Sensor 1 or Sensor 2, as appropriate.

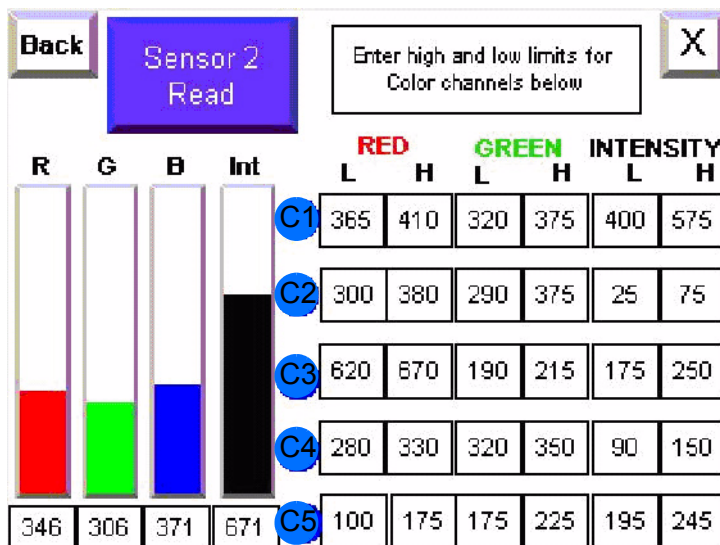

2. Place the target color to be read in front of the 45CLR ColorSight sensor.
3. Press the Sensor 1 Read button on the HMI.

This activates the 45CLR ColorSight sensor. You can now see values for the RGB and Intensity values on the PanelView Component terminal.

4. To enter high and low limits for the red, green, and intensity values for the first color channel, C1, touch the field you wish to change on the PanelView Component terminal, enter a value on the HMI, and press the Return key.
5. Read the same target color by repeating step 3 to trigger a second read by the 45CLR ColorSight sensor.

If the read values all fall within the thresholds you set in step 4, then the controller will activate 0:0/0 for 5 seconds.





In this application, an additional four colors can be set by reading and then setting the high and low limits of C2...C5.

Note: The highest limit that can be entered is 1023. The lowest is 0.

6. Once the channels are set up and validated, save the Micrologix 1400 program.

## Resetting the 45CLR to Factory Defaults

(Optional - This procedure was referenced in [Set Sensor Node Address and Baud Rate, page 17.](#))  
Follow these instructions to reset the 45CLR to factory defaults.

1. Press and hold the  button until the yellow LED labeled 'C' flashes more than three seconds.
2. Press  four times.
3. Press  two times. The red and green LEDs flash alternately to confirm.
4. Press  four times.
5. Press .

## Additional Resources

Refer to [page 9](#) for a listing of product and information resources.

**Notes:**

**Notes:**



# Rockwell Automation Support

Rockwell Automation provides technical information on the Web to assist you in using its products. At <http://support.rockwellautomation.com>, you can find technical manuals, a knowledge base of FAQs, technical and application notes, sample code and links to software service packs, and a MySupport feature that you can customize to make the best use of these tools.

For an additional level of technical phone support for installation, configuration, and troubleshooting, we offer TechConnect Support programs. For more information, contact your local distributor or Rockwell Automation representative, or visit <http://support.rockwellautomation.com>.

## Installation Assistance

If you experience a problem with a hardware module within the first 24 hours of installation, please review the information that's contained in this manual. You can also contact a special Customer Support number for initial help in getting your module up and running.

|                       |  |
|-----------------------|--|
| United States         | 1.440.646.3434<br>Monday – Friday, 8 a.m. - 5 p.m. EST   |
| Outside United States | Please contact your local Rockwell Automation representative for any technical support issues. |

## New Product Satisfaction Return

Rockwell tests all of its products to ensure that they are fully operational when shipped from the manufacturing facility. However, if your product is not functioning, it may need to be returned.

|                       |   |
|-----------------------|---|
| United States         | Contact your distributor. You must provide a Customer Support case number (see phone number above to obtain one) to your distributor in order to complete the return process. |
| Outside United States | Please contact your local Rockwell Automation representative for return procedure.  |

[www.rockwellautomation.com](http://www.rockwellautomation.com)

### Power, Control and Information Solutions Headquarters

Americas: Rockwell Automation, 1201 South Second Street, Milwaukee, WI 53204-2496 USA, Tel: (1) 414.382.2000, Fax: (1) 414.382.4444

Europe/Middle East/Africa: Rockwell Automation, Vorstlaan/Boulevard du Souverain 36, 1170 Brussels, Belgium, Tel: (32) 2 663 0600, Fax: (32) 2 663 0640

Asia Pacific: Rockwell Automation, Level 14, Core F, Cyberport 3, 100 Cyberport Road, Hong Kong, Tel: (852) 2887 4788, Fax: (852) 2508 1846