

MicroLogix 1400 Controller



The MicroLogix 1400 controller is our newest family of controllers to join the popular MicroLogix 1000, MicroLogix 1100, MicroLogix 1200, and MicroLogix 1500 controllers, and is designed to broaden application coverage through available embedded analog inputs, Ethernet communication, faster high-speed counter (HSC), and pulse train output (PTO) capabilities. MicroLogix 1400 controllers maintain the same critical features you have come to expect from the MicroLogix 1100 controller, and expands that capability with more I/O, faster HSC/PTO, and an additional serial port. MicroLogix 1400 controllers complement our low-end controllers for applications that require up to 256 digital I/O.

Each MicroLogix 1400 controller includes 20 digital inputs and 12 digital outputs. In addition, several models include 4 embedded analog inputs and 2 embedded analog outputs. The controller can also expand its I/O capabilities by using the same modules as the MicroLogix 1100 and 1200 controllers. Up to 7 of the 1762 I/O modules can be used with a single MicroLogix 1400 controller.

Using the latest version of our world-class RSLogix 500 programming software, the MicroLogix 1400 controller can be programmed with an instruction set that is common with the MicroLogix 1000, MicroLogix 1100, MicroLogix 1200, MicroLogix 1500, and SLC 500 families of controllers. RSLogix 500 Starter, Standard, and Professional applications, as well as RSLogix Micro software, all support the MicroLogix 1400 controller, including its online editing capabilities.

Each controller has 2 serial ports with DF1/DH485/Modbus RTU/DNP3/ASCII protocol support and a built-in Ethernet port, which supports EtherNet/IP, Modbus TCP/IP and DNP3 over IP.

An embedded LCD screen lets you monitor controller and I/O status, as well as make changes to bit and integer data.

Advantages for the MicroLogix 1400 Controller

- Large memory (10 KB user program with 10 KB user data) to solve a variety of applications.
- True online editing allows tuning of program, including PID, without going offline.
- Support for MicroLogix 1400 controller online editing in RSLogix 500 Professional, Standard, and Starter software version 8.1 and later, as well as RSLogix Micro.
- Mode switch for Run/Remote/Program through LCD keypad operation.
- Time-based or event-triggered data logging capability stores controller data records with optional time stamp in a separate 128 Kbyte memory area for later analysis (for example, trending and I/O status during alarm condition data).
- Recipe storage (up to 64 KB that is deducted from Data Logging memory) that is accessible by your ladder program, enabling quick and easy batch changes of program data for timers, counters, and other data types.
- High performance expansion I/O options (up to seven 1762 I/O modules, in any combination).
- Twelve high-speed inputs (except 1766-L32AWA and 1766-L32AWAA controllers) that can be used individually as latching (pulse-catch) inputs, event interrupts, or alternately combined as three 100 kHz high-speed counters featuring 10 modes of operation.
- Two available built-in 0...10V DC analog outputs (for controllers with analog I/O options) with 12-bit resolution (not isolated).
- Three high-speed outputs that can be configured as 100 kHz pulse train output (PTO) or 40 kHz as pulse width modulated (PWM) outputs (only on 1766-L32BXB and 1766-L32BXBA controllers).
- Multiple input commons let you use the controller for either sinking or sourcing input devices, and multiple output commons provide individual isolation in multi-voltage output applications.
- One, 1 ms, selectable timed interrupt (STI).
- High-resolution, 1 ms timers.
- Communication Channel 0 provides isolated RS-232 or RS-485 electrical compatibility (selectable through the choice of communication cables).
- Through RS-232, we support all serial protocols.
- Through RS-485, we support direct interface to DH-485, DF1 half-duplex master/slave, ASCII, and Modbus RTU master/slave networks, DNP 3 slave using the 1763-NC interface (1761-NET-AIC interface is not required).
- Communication Channel 1 consists of an embedded RJ45 port that supports EtherNet/IP, Modbus TCP/IP and DNP3 over IP. This 10/100 Mbps port supports BOOTP and DHCP.
- Communication channel 2 provides a 9-pin, non-isolated RS-232 port supporting all serial protocols.
- Communication toggle selection that allows the controller's Channel 0 port to toggle between user-configured communication parameters and factory default settings for an easy way to switch from Modbus RTU or ASCII protocols (which do not support programming) to DF1 full-duplex (to upload/download, monitor, or edit your program). So a programming computer is able to connect to a controller with an unknown or incorrect communication-parameter settings for troubleshooting.
- Embedded real-time clock.
- Embedded web server with email functionality.

- Optional memory module for external program backup, for program transport, and transfer to another controller. Program and data in the controller is also battery backed for secure storage.
- Data file download protection prevents critical user data from being altered via program downloads from programming computers or memory modules.
- Built-in LCD provides access to binary and integer files that can be changed, or optionally protected, for monitor only access by an operator.
- LCD instruction allows the controller to output messages to the LCD, and optionally receive user input.
- IP address can be monitored and configured directly through the built-in LCD.
- Two built-in digital trim potentiometers.
- 32-bit signed integer math.
- Floating-point and double-integer data file support.
- Built-in PID capabilities.
- Finger-safe removable terminal blocks meet global safety standards.
- Customizable OEM logos on the LCD display.
- Regulatory agency certifications for world-wide market (CE, C-Tick, cUL, and UL including Class 1 Division 2 Hazardous Location, where product is marked⁽¹⁾).

(1) See the Product Certification link at <http://www.ab.com> for Declaration of Conformity, Certificates, and other certification details.

Select Family: MicroLogix 1100 or 1400 Controller

Step 1 - Select:

- controller family - based on memory, I/O, added functionality, programming instructions and dimensions
- consider future expansion requirements
- consider requirement for online editing
- consider the need for networked communication

Review the Features, Programming Instructions, Controller Specifications, and Controller Dimensions to determine which level of MicroLogix controller is required.

Features

MicroLogix Controllers Feature Comparison Chart

Controller	MicroLogix 1100	MicroLogix 1400
Bulletin Number	1763	1766
Memory (in user words) User Program/User Data		
Up to 1 KB		
Up to 6 KB		
Up to 7 KB		
Up to 8 KB	4 KB/4 KB	
Up to 14 KB		
Up to 20 KB		10 KB/10 KB
Online editing	✓	✓
Nonvolatile program and data	Battery back-up static RAM	Battery back-up static RAM
Memory Module (for program back-up and transport)	Optional	Optional
I/O		
Embedded Digital I/O, max	16	32
Embedded Analog I/O	Two 0...10V DC inputs on all controllers	Four 0...10V DC inputs on some controllers Two 0...10V DC outputs on some controllers
Local Expansion I/O, max	144	256
Thermocouple/RTD	Expansion	Expansion
Added Functionality		
Trim Potentiometers	Two (digital)	Two (digital)
PID	✓	✓
High Speed Counters (embedded)	One @ 40 kHz	Up to six @ 100 kHz
Real Time Clock	✓	✓
Motion: Pulse Width Modulated	2 @ 40 kHz	3 @ 40 kHz
Motion: Pulse Train Outputs	2 @ 40 kHz	3 @ 100 kHz
Data Access Tool	✓	✓
Data Logging	128 KB	128 KB
Recipe Storage	Uses up to 64 KB data logging memory	Uses up to 64 KB data logging memory
Floating Point Math	✓	✓
Programming		
Windows - RSLogix 500 Software	✓	✓
RSLogix Micro	✓	✓
Communication		
RS-232 Ports	(1) 8-pin mini DIN	(1) 8-pin mini DIN (1) 9-pin D-shell
DeviceNet Peer-to-Peer Messaging, slave I/O	With 1761-NET-DNI	With 1761-NET-DNI
EtherNet/IP	✓	✓
Web Server Capabilities	✓	✓
DH-485	Network with 1763-NC01	Network with 1763-NC01

MicroLogix Controllers Feature Comparison Chart

Controller	MicroLogix 1100	MicroLogix 1400
Bulletin Number	1763	1766
SCADA RTU - DF1 half-duplex master/slave	✓	✓
SCADA RTU - DF1 radio modem	✓	✓
SCADA RTU - Modbus RTU slave	✓	✓
SCADA RTU - Modbus RTU master	✓	✓
SCADA RTU - DNP3 slave		✓
ASCII - Read/Write	✓	✓
DNP3 over IP		✓
Modbus TCP/IP		✓
Operating Power		
120/240V AC	✓	✓
24V DC	✓	✓
12V DC	✓	
Agency Certifications		
CE, C-Tick, UL, and C-UL (including Class I, Division 2 Hazardous Location) ⁽¹⁾	✓	✓

(1) See the Product Certification link at <http://www.ab.com> for Declarations of Conformity, Certificates, and other certification details.

Programming Instructions

MicroLogix controllers have the range of functionality necessary to address diverse applications. The controllers use the following types of instructions:

- Basic instructions (for example, Examine if On, Examine if Off)
- Data Comparison instructions (for example, Equal, Greater than or Equal, Less than or Equal)
- Data Manipulation instructions (for example, Copy, Move)
- Math instructions (for example, Add, Subtract, Multiply)
- Program Flow Control instructions (for example, Jump, Subroutine)
- Application Specific instructions (for example, Programmable Limit Switch, Sequencer)
- High-speed Counter instruction
- High-speed pulse train output (PTO) and pulse width modulated (PWM) instructions
- Communication instruction including ASCII
- Recipe instruction
- Data Logging instruction
- LCD instruction
- Trigonometry instructions (MicroLogix 1400 controllers only)
- Advanced math instructions (for example, x^y , compute - MicroLogix 1400 controllers only)
- Advanced timing instructions (for example, Read High-speed clock, compute time difference - MicroLogix 1400 controllers only)

Controller Specifications

Controller General Specifications

Attribute	MicroLogix 1100 (Bulletin 1763)	MicroLogix 1400 (Bulletin 1766)
Memory Size and Type	8 KB battery backed RAM: 4 K user program, 4 K user data	20 KB battery backed RAM: 10 K user program, 10 K user data
Data Elements	configurable, user defined file structure, 4 KB max data size	configurable, user defined file structure, 10 KB max data size
Throughput	1.5 ms (for a typical 1 KB word user program) ⁽¹⁾	0.7 ms (for a typical 1 KB word user program) ⁽¹⁾

(1) A typical user program contains bit, timer, counter, math, and file instructions.

Environmental Specifications and Certifications

Attribute	1763 Controllers	1766 Controllers
Operating Temperature	-20...65 °C (-4...149 °F)	-20...60 °C (-4...140 °F)
Storage Temperature	-40...85 °C (-40...185 °F)	-40...85 °C (-40...185 °F)
Relative Humidity	5...95%, noncondensing	5...95%, noncondensing
Vibration	10...500 Hz, 5 g, 0.015 in. max peak-to-peak, (Relay Operation: 1.5 g)	10...500 Hz, 3 g, 0.015 in. max peak-to-peak
Shock, Operating	30 g; 3 pulses each direction, each axis (Relay Operation: 7 g)	30 g; 3 pulses each direction, each axis
Shock, Nonoperating	50 g panel mounted (40 g Din Rail mounted); 3 pulses each direction, each axis	50 g panel mounted (40 g Din Rail mounted); 3 pulses each direction, each axis
Agency Certification	<ul style="list-style-type: none"> UL Listed Industrial Control Equipment for use in Class 1, Division 2, Hazardous Locations, Groups A, B, C, D C-UL Listed Industrial Control Equipment for use in Canada CE marked for all applicable directives C-Tick marked for all applicable acts 	<ul style="list-style-type: none"> UL Listed Industrial Control Equipment for use in Class 1, Division 2, Hazardous Locations, Groups A, B, C, D C-UL Listed Industrial Control Equipment for use in Canada CE marked for all applicable directives C-Tick marked for all applicable acts
Electrical/EMC		
ESD Immunity	EN 61000-4-2 4 kV contact, 8 kV air, 4 kV indirect	EN 61000-4-2 4 kV contact, 8 kV air
Radiated Immunity	ENV 50204 10 V/m, 1000 MHz	
Radiated RF Immunity	EN 61000-4-3 10V/m, 26...1000 MHz (alternatively, 80...1000 MHz), 80% amplitude modulation, +900 MHz keyed carrier	EN 61000-4-3 10V/m, 26...1000 MHz (alternatively, 80...1000 MHz), 80% amplitude modulation, +900 MHz keyed carrier

Environmental Specifications and Certifications

Attribute	1763 Controllers	1766 Controllers
Electronic Fast Transient/Burst (EFT/B) Immunity	EN 61000-4-4 2 kV, 5 kHz communication cable such as EtherNet, RS-232, and RS-485: 1 kV, 5 kHz	EN 61000-4-4 2 kV, 5 kHz communication cable such as EtherNet, RS-232, and RS-485: 1 kV, 5 kHz
Surge Transient Immunity	EN 61000-4-5 Unshielded communication cable: 2 kV CM (common mode), 1 kV DM (differential mode) Shielded communication cable: 1 kV galvanic gun I/O: 2 kV CM (common mode), 1 kV DM (differential mode) AC Power Supply Input: 4 kV CM (common mode), 2 kV DM (differential mode) DC Power Supply Input: 500V CM (common mode), 500V DM (differential mode) AC/DC Auxiliary Output: 500V CM (common mode), 500V DM (differential mode)	EN 61000-4-5 ±1 kV line-line (DM) and ±2 kV line-earth (CM) on AC power ports ±1 kV line-line (DM) and ±2 kV line-earth (CM) on signal ports ±1 kV line-earth (CM) on communication ports
Conducted RF Immunity	EN 61000-4-6 10V, 150 kHz...80 MHz	EN 61000-4-6 10V, 150 kHz...80 MHz
Conducted Emissions	EN 55011 AC Power Supply Input: 150 kHz...30 MHz	EN 55011 AC Power Supply Input: 150 kHz...30 MHz
Radiated Emissions	EN 55011 30...1000 MHz	EN 55011 30...1000 MHz
Line Related Tests	EN 61000-4-11 AC Power Supply Input: voltage drop: -30% for 10 ms, -60% for 100 ms voltage interrupt: at voltage greater than -95% for 5 s. voltage fluctuation: +10% for 15 minutes, -10% for 15 minutes DC Power Supply Input: voltage fluctuation: +20% for 15 minutes, -20% for 15 minutes	EN 61000-4-11 60% dip for 10 periods on AC supply ports 30% dips for 25 periods at 0x and 180x on AC supply ports 100% dip for 250 periods at 0x and 180x on AC supply ports 100% dip for 0.5 periods, arbitrary angle, on AC supply ports

Controller Dimensions

MicroLogix 1000 Controller

Dimensions are in millimeters (inches).

Controller Spacing = 50 mm (2 in.) on all sides for adequate ventilation.

MicroLogix Controller Dimensions

**1761-L10BWA, 1761-L10BWB, 1761-L10BXB,
1761-L16BBB, 1761-L16BWA, 1761-L16BWB,
1761-L16NWA, 1761-L16NWB**

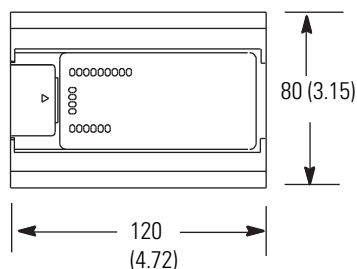

1761-L16AWA

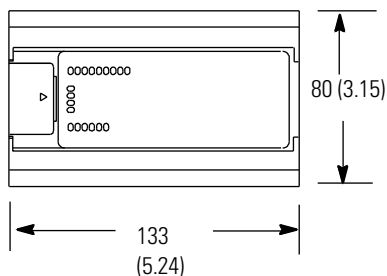

**1761-L20AWA, 1761-L20BWA, 1761-L20BWB,
1761-L32AWA, 1761-L32BWA, 1761-L32AAA,
1761-L32BBB, 1761-L32BWB**

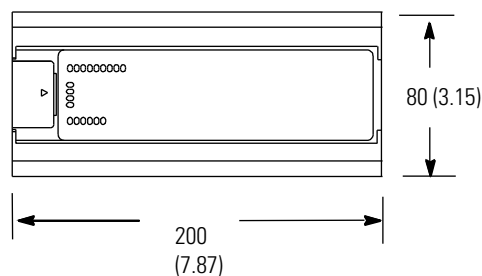

**1761-L10BWA, 1761-L16AWA, 1761-L16BWA,
1761-L16NWA, 1761-L20AWA, 1761-L20BWA,
1761-L32AWA, 1761-L32BWA, 1761-L32AAA**

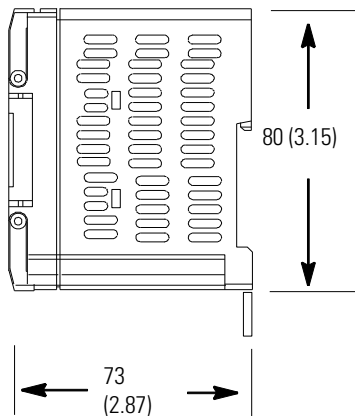

**1761-L10BWB, 1761-L16BWB,
1761-L16BBB, 1761-L16NWB,
1761-L20BWB, 1761-L32BWB,
1761-L32BBB**

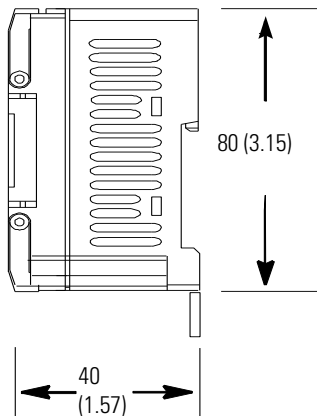

MicroLogix 1000 DIN Rail Dimensions

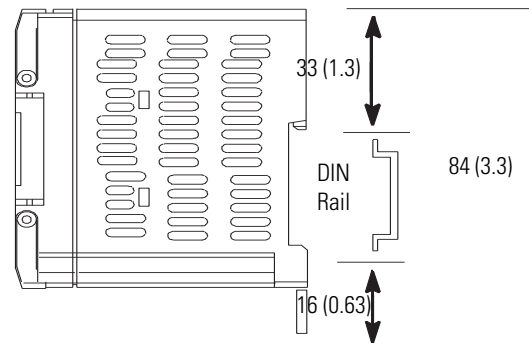

Select MicroLogix 1400 Controllers

MicroLogix 1400 Base Units

The base unit houses embedded inputs, outputs, power supply, and communication ports. The base unit also provides the interface to expansion I/O when required by an application.

Step 10 - Select:

- controller - review power and I/O configurations to select a controller catalog number; see power supply and I/O specification for more detailed information
- accessories - memory modules
- record your selection in the Selection Record (starts on [page 86](#))

MicroLogix 1400 Controller Catalog Number Detail

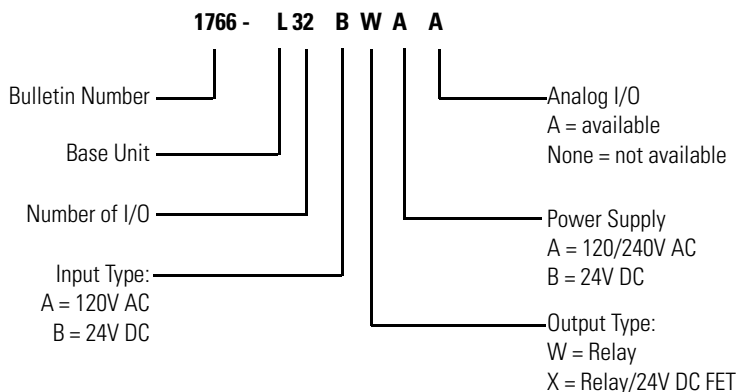

MicroLogix 1400 Controller Power and I/O Configuration

Cat. No.	Line Voltage	Number of Inputs	Number of Outputs	Embedded Analog I/O
1766-L32BWA	120/240V AC	(12) Fast 24V DC (8) Normal 24V DC	(12) Relay	---
1766-L32AWA	120/240V AC	(20) 120V AC	(12) Relay	---
1766-L32BXB	24V DC	(12) Fast 24V DC (8) Normal 24V DC	(6) Relay (3) Fast 24V DC (3) Normal 24V DC	---
1766-L32BWAA	120/240V AC	(12) Fast 24V DC (8) Normal 24V DC	(12) Relay	(4) Voltage Inputs (2) Voltage Outputs
1766-L32AWAA	120/240V AC	(20) 120V AC	(12) Relay	(4) Voltage Inputs (2) Voltage Outputs
1766-L32BXBA	24V DC	(12) Fast 24V DC (8) Normal 24V DC	(6) Relay (3) Fast 24V DC (3) Normal 24V DC	(4) Voltage Inputs (2) Voltage Outputs

MicroLogix 1400 Controller Power Supply Specifications

Attribute	1766-L32AWA, 1766-L32AWAA	1766-L32BWA, 1766-L32BWAA	1766-L32BXB, 1766-L32BXBA
Power Supply Voltage	100...240V AC (-15%, 10%) at 47...63 Hz		24V DC (-15%, 10%) Class 2 SELV

MicroLogix 1400 Controller Power Supply Specifications

Attribute	1766-L32AWA, 1766-L32AWAA	1766-L32BWA, 1766-L32BWAA	1766-L32BXB, 1766-L32BXBA
Power Consumption	100 VA	120 VA	7.5...53 W
Power Supply Inrush Current, max	120V AC: 25 A for 8 ms 240V AC: 40 A for 4 ms		24V DC: 15 A for 20 ms
24V DC Sensor Power	---	24V DC at 250 mA, 400µF capacitance, max	---

MicroLogix 1400 Controller DC Input Power Requirements for 1766-L32BXB and 1766-L32BXBA Units

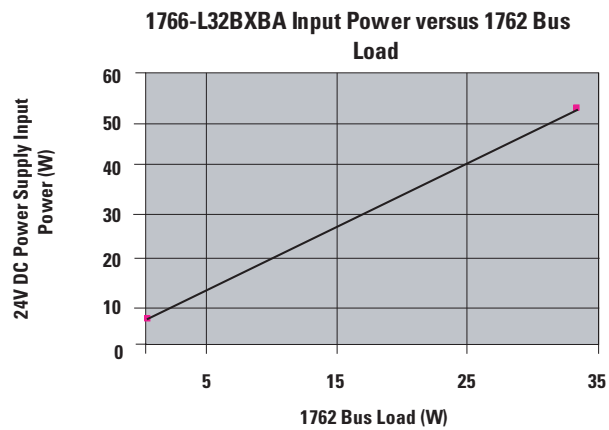

MicroLogix 1400 Controller Digital Input Specifications

Attribute	1766-L32AWA, 1766-L32AWAA	1766-L32BWA, 1766-L32BWAA, 1766-L32BXB, 1766-L32BXBA	
		Inputs 0...11 (12 high-speed DC inputs)	Inputs 12 and above (8 standard DC inputs)
On-state Voltage Range	79...132V AC	4.5...24V DC 4.5...26.4V DC at 60 °C (140 °F) 4.5...30V DC at 30 °C (86 °F)	10...24V DC 10...26.4V DC at 60 °C (140 °F) 10...30V DC at 30 °C (86 °F)
Off-state Voltage Range	0...20V AC	0...1.5V DC	0...5V DC
Operating Frequency	47...63 Hz	0 Hz...100 kHz	0 Hz...1 kHz (scan time dependent)
On-state Current min nom max	5.0 mA @ 79 V AC 12 mA @ 120 V AC 16.0 mA @ 132 V AC	7.1 mA @ 4.5V DC 9.9 mA @ 24V DC 10.5 mA @ 30V DC	3.2 mA @ 10V DC 5.3 mA @ 24V DC 5.5 mA @ 30V DC
Off-state Leakage Current, max	2.5 mA, max	0.2 mA, max	1.5 mA, max
Impedance, nom	12 k Ω at 50 Hz 10 k Ω at 60 Hz	2.4 k Ω	4.5 k Ω
Inrush Current, max	250 mA		

MicroLogix 1400 Controller Analog Input Specifications

Attribute	Value
Voltage Input Range	0...10.0V DC - 1 LSB
Type of Data	12-bit unsigned integer
Input Coding (0...10V DC)	0...4095
Voltage Impedance	>199 k Ω
Input Resolution	12 bit
Non-linearity (in percent full scale)	\pm 0.5% of full scale
Overall Accuracy	\pm 1.0% of full scale
Update Time	100/20/16.67/4 ms (selectable)
Voltage Input Overvoltage Protection	10.5 V DC
Field Wiring to Logic Isolation	Non-isolated with internal logic

MicroLogix 1400 Controller Analog Output Specifications

Attribute	Value
Voltage Output Range	0...10.0V DC - 1 LSB
Type of Data	12-bit unsigned integer
Step Response	2.5 ms @ 95%
Output Coding (0...10V DC)	0...4095
Load Range Voltage Output	>1 k Ω
Output Resolution	12 bit
Analog Output Setting Time	3 ms, max
Overall Accuracy	\pm 1.0% of full scale
Electrical Isolation	Non-isolated with internal logic
Cable Length	30 m (98 ft) shielded cable

Specifications for MicroLogix 1400 Controller Outputs in Hazardous locations (Class 1, Division 2, Groups A, B, C, D)

Relay and FET Outputs

Attribute		1766-L32AWA, 1766-L32AWAA, 1766-L32BWA, 1766-L32BWAA	1766-L32BXB, 1766-L32BXBA
Controlled Load, max		1440 VA	1080 VA
Continuous Current, max			
Current per Channel and Group Common		2.5 A per channel 8 A max channel 8...11 common	2.5 A per channel
Current per Controller	@ 150V, max	28 A or total of per-point loads, whichever is less	
	@ 240V, max	20 A or total of per-point loads, whichever is less	

Relay Outputs

Attribute	Value
Turn On Time/Turn Off Time	10 ms, max ⁽¹⁾
Load Current	10 mA

(1) Scan time dependent.

Relay Contact Rating

Voltage, max	Amperes		Amperes Continuous	Voltamperes	
	Make	Break		Make	Break
240V AC	7.5 A	0.75 A	2.5 A	1800 VA	180 VA
120V AC	15 A	1.5 A			
250V DC	0.11 A		1.0 A	28 VA	
125V DC	0.22 A		1.0 A	28 VA	

1766-L32BXB, 1766-L32BXBA FET Outputs

Attribute	General Operation	High-speed Operation (outputs 2, 3, and 4 only) ⁽¹⁾
Power Supply Voltage (Class 2)	24V DC (-15%, +10%)	
On-state Voltage Drop at maximum load current at maximum surge current	1V DC 2.5V DC	Not Applicable Not Applicable
Current Rating per Point maximum load minimum load maximum leakage	See chart 1.0 mA 1.0 mA	100 mA 20 mA 1.0 mA

1766-L32BXB, 1766-L32BXBA FET Outputs

Attribute	General Operation	High-speed Operation (outputs 2, 3, and 4 only) ⁽¹⁾
Surge Current per Point peak current	4.0 A	Not Applicable
maximum surge duration	10 ms	Not Applicable
maximum rate of repetition at 30 °C (86 °F)	once every second	Not Applicable
maximum rate of repetition at 65 °C (149 °F)	once every 2 seconds	Not Applicable
Turn-on Time, max	11 μs	28 ns
Turn-off Time, max	89 μs	2.3 μs

(1) Output 2, 3, and 4 are designed to provide increased functionality over the other FET outputs. Outputs 2, 3, and 4 may be used like the other FET transistor outputs, but in addition, within a limited current range, they may be operated at a higher speed. Outputs 2, 3, and 4 also provide a pulse train output (PTO) or pulse width modulation output (PWM) function.

MicroLogix 1400 Controller FET Standard Outputs

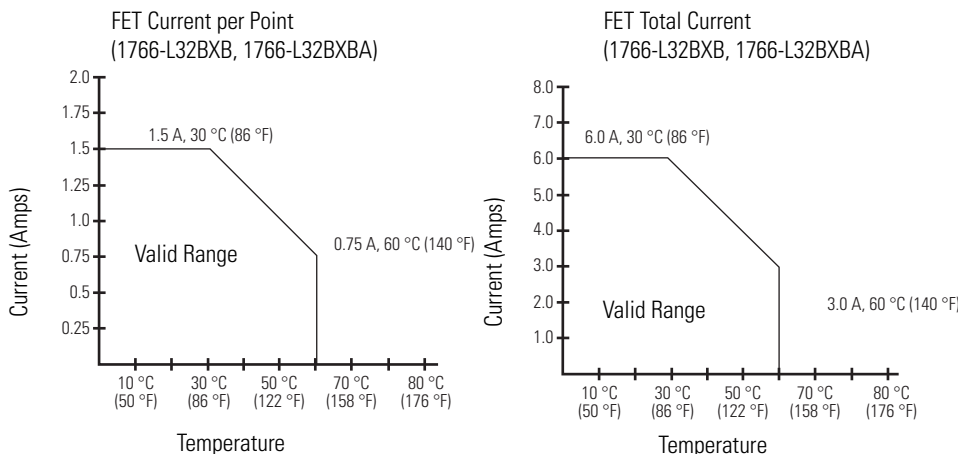

MicroLogix 1400 Memory Module (1766-MM1)

The controller is shipped with a memory module port cover in place. You can order the memory module to provide removable backup of your User Program and User Data, or to transport your program between controllers.

Memory modules allow:

- user programs and data to be store as backup.
- transport programs for use with other controllers.
- special safety/security features for press control and other critical applications.
- auto-recovery, through a power cycle, after a controller fault.
- comparison of programs.
- data file and memory module write protection.
- removal/insertion under power.

Select MicroLogix 1400 Expansion I/O

Step 11 - Select:

- I/O modules - digital, analog, and temperature
- record your selections in the Selection Record (start on [page 86](#))

MicroLogix 1400 controllers expand by using the same 1762 I/O platform as MicroLogix 1100 controllers. The 1762 I/O expansion modules provide superior functionality in a small sized low-cost package. A variety of modules complement and extend the capabilities of MicroLogix 1400 controllers by maximizing the flexibility of I/O count and type.

The MicroLogix 1400 system design allows modules to be either DIN rail or panel mounted. The DIN latches and screw mounting holes are an integral part of the package design.

Controller I/O can be expanded by using up to seven expansion modules per controller.

See [Select MicroLogix 1100 Expansion I/O on page 50](#) for available modules and specifications.

1762 Expansion I/O Modules Connected to a MicroLogix 1400 Controller



Select Replacement Parts

Step 14 - Select:

- replacement parts
- record your selections in the Selection Record (start on [page 86](#))

MicroLogix 1000 Replacement Parts

Description	Cat. No.
Terminal Cover Doors for 1761-L32AWA, -L32BWA, or -L32AAA (2 doors per package)	1761-RPL-T32X
Replacement Terminal Block — 6-position DH-485 plug/connector used with the 1761-NET-AIC.	1746-RT30
Replacement Terminal Block — 5-position DeviceNet plug/connector used with the 1761-NET-DNI.	1761-RPL-RT00

MicroLogix 1100 Replacement Part

Description	Cat. No.
Replacement Battery	1763-BA

MicroLogix 1200 Replacement Parts

Description	Cat. No.
Replacement Removable Terminal Block — (1) 25-pt double row, (1) 29-point double row for 1762-L40AWA and -L40BWA	1762-RPLRTB40

MicroLogix 1400 Replacement Parts

Description	Cat. No.
Replacement Battery	1747-BA
Replacement Removable Terminal Block — (1) 25-pt double row, (1) 29-point double row for all 1766-L32xxxx	1762-RPLRTB40

MicroLogix 1500 Replacement Parts

Description	Cat. No.
Replacement Terminal Block — 17-pt for 1764-24AWA and 1764-24BWA inputs	1764-RPLTB1
Replacement Terminal Block — 21-pt for 1764-28BxB inputs and outputs for all base units	1764-RPLTB2
Replacement Battery	1747-BA