

POINT I/O Family

Overview



The POINT I/O family has modular I/O modules that are ideal for applications where flexibility and low-cost of ownership are key for successful control system design and operation. As a key element in the Rockwell Automation Integrated Architecture, its comprehensive diagnostics and configurable features allow the product to be easily applied to any automation system and reduce engineering costs through standardization. It can be used in remote device panels, local control panels, and can be accessed from many locations including the Internet. This product has just-what-you-need granularity in 1 to 8 points to reduce system cost and size.

Available features include Channel Level Diagnostics for quick troubleshooting, multiple termination options and flexibility to save money, cabinet space and commissioning/troubleshooting time, the ability to mix/match Safety I/O on the same bus, and available DeviceLogix for local control, fast response time. Self-Configuring modules are also available to reduce/simplify your design and your inventory.

The POINT I/O System

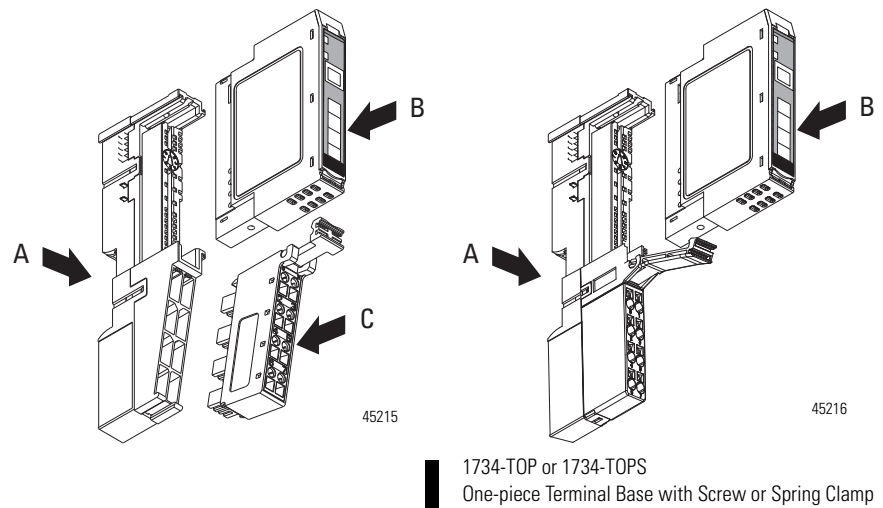

The base (A) mounts onto the DIN rail and provides the backplane. The POINT I/O module (B) snaps into the base. The removable terminal block (C) also snaps into the base and provides the wiring and terminations for field-side connections, as well as system power for the backplane.

POINT I/O has 4 major components:

- I/O modules provide the field interface and system-interface circuitry
- Communication interface modules provide the network-interface circuitry
- Terminal base units provide the wiring and signal termination for field-side connections and system power for the backplane
- Power distribution modules provide the expandability of the POINT I/O system and the flexibility to mix a variety of signal types

1734 POINT I/O modules offer 1 to 8 points per module. The I/O modules are interfaced to a network through a communication interface, which includes a built-in power supply that converts incoming 24V DC power to 5V DC backplane power. Each type of communication interface (Network Adaptor) supports a maximum of 13 to 17 I/O modules, with a maximum of 10 A field power. The I/O modules receive power from the power supply through the backplane. With an external power supply, you can expand a POINT I/O assembly up to a maximum of 63 I/O modules or 504 channels.

1734D Series POINTBlock I/O provides a DeviceNet communication interface with up to 16 integrated I/O points in a single module. You can add up to 13 POINT I/O modules to a POINTBlock I/O assembly, for a maximum of 120 channels per assembly.

POINT I/O Features

Adapters	<ul style="list-style-type: none"> • ControlNet • DeviceNet • EtherNet I/P • Profibus
I/O Types	<ul style="list-style-type: none"> • Digital • Analog • AC/DC • Thermocouple • RTD • Specialty
Module Density	1...8 points
Specialty Modules	<ul style="list-style-type: none"> • Encoder • 1 MHz Counter In • Counter In with Outputs • Serial RS232 • RS485 • RS422 • Channel Isolated Thermocouple • RTD • Serial Synchronous Interface (SSI) • Address Reserve
Module Features	<ul style="list-style-type: none"> • Channel-level diagnostics (LED indicator and electronic) • Channel-level alarm and annunciation (electronic) • Channel-level open-wire detection with electronic feedback • Channel-level short-circuit detection with electronic feedback • Parameter-level explicit messaging • Removal and insertion under power (RIUP) • Horizontal or vertical mounting without derating • Automatic Device Replacement • Add-On-Profiles in RSLogix 5000
Network Connectivity	<ul style="list-style-type: none"> • DeviceNet (including SubNet connectivity) • ControlNet (Logix controller only) • EtherNet/IP (Logix controller only) • PROFIBUS DP • OPC/DDE Data Monitoring"
Environmental Style	Class I, Division 2/Zone 2, Marine Certification, European ATEX Zone 2 3G
Modules per Node, max	Up to 63

Specify a POINT I/O System

Follow these steps as you specify your POINT I/O system:

	Step	Remember to select
✓	<p>1 Select a communication interface</p> <p>Choose the interface module for your operating system.</p>	<ul style="list-style-type: none"> the appropriate interface module a communication interface that meets the power requirements of your system
✓	<p>2 Select I/O devices based on field devices</p> <ul style="list-style-type: none"> location of the device number of points needed appropriate catalog number number of points available per module number of modules 	<ul style="list-style-type: none"> I/O modules - some have diagnostic features, electronic fusing, isolated inputs/outputs, and unique configurable features
✓	<p>3 Select a wiring base assembly</p> <p>Choose the appropriate wiring base assembly</p>	<ul style="list-style-type: none"> the appropriate wiring base assembly: <ul style="list-style-type: none"> Single piece screw, single piece spring, or RTB (Removable Terminal Base)
✓	<p>4 Select optional power components</p> <p>Choose optional components to extend backplane power or change the field power distribution source.</p>	<ul style="list-style-type: none"> additional power components as necessary adequate power capacity to meet I/O module backplane current requirements
✓	<p>5 Determine mounting requirements</p> <p>Determine needed dimensions based on the communication interface chosen.</p>	<ul style="list-style-type: none"> the appropriate number of DIN rails based on the number of modules and the physical locations of those modules horizontal or vertical mounting with no thermal derating

Select POINT I/O Communication Interfaces

Step 1 - Select:

- a communication interface module

NetLinx Open Network Architecture.....	page 9
EtherNet I/P Network.....	page 11
ControlNet Network.....	page 12
DeviceNet Network.....	page 15
PROFIBUS DP Network.....	page 18

Overview

Separate communication interface adapters are available for different networks. Install adapters into the POINTBus backplane to allow POINT I/O modules to communicate with a controller.

NetLinx Open Network Architecture

NetLinx Open Network Architecture is the Rockwell Automation strategy of using open networking technology for seamless, top-floor to shop-floor integration. The NetLinx-based networks – DeviceNet, ControlNet, and EtherNet/IP – all use the Common Industrial Protocol (CIP), so they speak a common language and share a universal set of communication services. NetLinx architecture, part of the Integrated Architecture platform, seamlessly integrates all the components in an automation system from a few devices on one network to multiple devices on multiple networks including access to the Internet – helping you to improve flexibility, reduce installation costs, and increase productivity.

- The EtherNet/IP network is an open industrial-networking standard that supports implicit and explicit messaging and uses commercial, off-the-shelf Ethernet equipment and physical media.
- The ControlNet network allows intelligent, high-speed control devices to share the information required for supervisory control, work-cell coordination, operator interface, remote device configuration, programming, and troubleshooting.

- The DeviceNet network offers low-cost, high-speed access to plant-floor data from a broad range of plant-floor devices and a significant reduction in wiring.

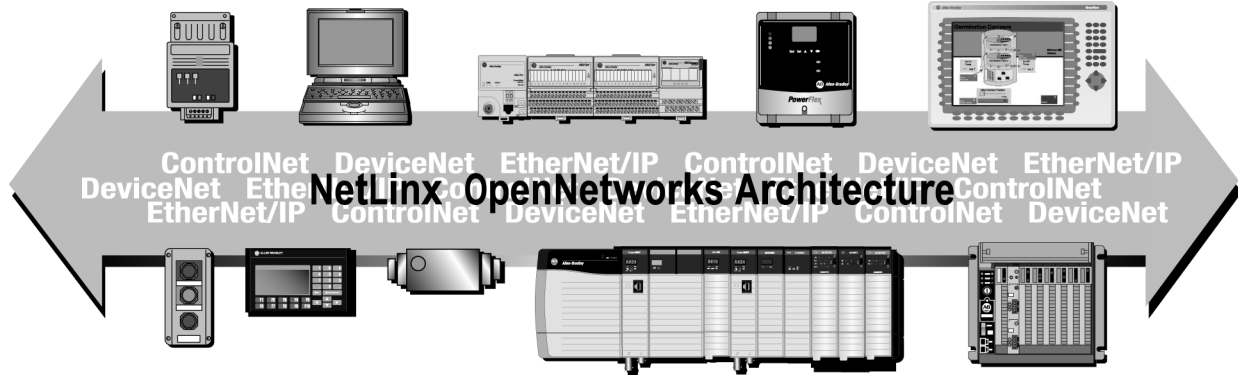

Select a Network

You can configure your system for information exchange between a range of devices and computing platforms and operating systems.

Application requirements	Network	Select
<ul style="list-style-type: none"> • Plant management (material handling) • Configuration, data collection, and control on a single, high-speed network • Time-critical applications with no established schedule • Data sent regularly • Internet/Intranet connection • Close IT & Manufacturing Integration • Built-in switch, or high availability requirement (2-port AENTR) 	EtherNet/IP	1734-AENT 1734-AENTR
<ul style="list-style-type: none"> • High-speed transfer of time-critical data between controllers and I/O devices • Deterministic and repeatable data delivery • Media redundancy • Controller redundancy • Intrinsic safety 	ControlNet	1734-ACNR
<ul style="list-style-type: none"> • Connections of low-level devices directly to plant-floor controllers, without interfacing them • Data sent as needed • More diagnostics for improved data collection and fault detection • Less wiring and reduced start-up time than a traditional, hard-wired system • High noise resistance, and power over network 	DeviceNet	1734-ADN 1734-ADN(X) 1734-PDN 1734D-series
<ul style="list-style-type: none"> • Connecting to an existing PROFIBUS DP 5 m (16.4 ft) bus, 12 MB network 	PROFIBUS	1734-APB

EtherNet I/P Network

The Ethernet Industrial (EtherNet/IP) network protocol is an open industrial-networking standard that supports both real-time I/O messaging and message exchange. It emerged due to the high demand for using the Ethernet network for control applications. The EtherNet/IP network uses off-the-shelf Ethernet communication chips and physical media. The EtherNet/IP network provides excellent drive and I/O control performance along with HMI information processing and many commercial technologies.

EtherNet/IP Network Considerations

Adapter	Considerations
1734-AENT 1734-AENTR	<p>A total of 63 POINT I/O modules can be assembled on a single EtherNet/IP node.</p> <p>Expansion power supplies may be used to provide additional POINTBus backplane current.</p> <p>Refer to the User Manual to determine the ratings for direct and rack connections allowed.</p>

The 1734-AENT/1734-AENTR adapter supports direct- and rack-optimized connections. A direct connection is a real-time data transfer link between the controller and whatever module occupies the slot that the configuration data references. Direct-connection messaging occurs at a cyclic rate specified by the requested packet interval (RPI) during configuration. A rack-optimized connection is a grouping of data from more than one I/O module into a single block of data sent over a single connection at the same data rate. Rack-optimized connections reduce the total number of connections needed to transfer data when using many I/O modules in a system.

Assume a system contains 8 digital I/O modules interfaced to a 1734-AENT/1734-AENTR adapter. If you used direct connections to transfer data to each of these modules, you need 8 connections — one to each of the 8 I/O modules. If you use a rack-optimized connection to transfer the

data, you need only a single connection — the connection to the 1734-AENT/1734-AENTR adapter.

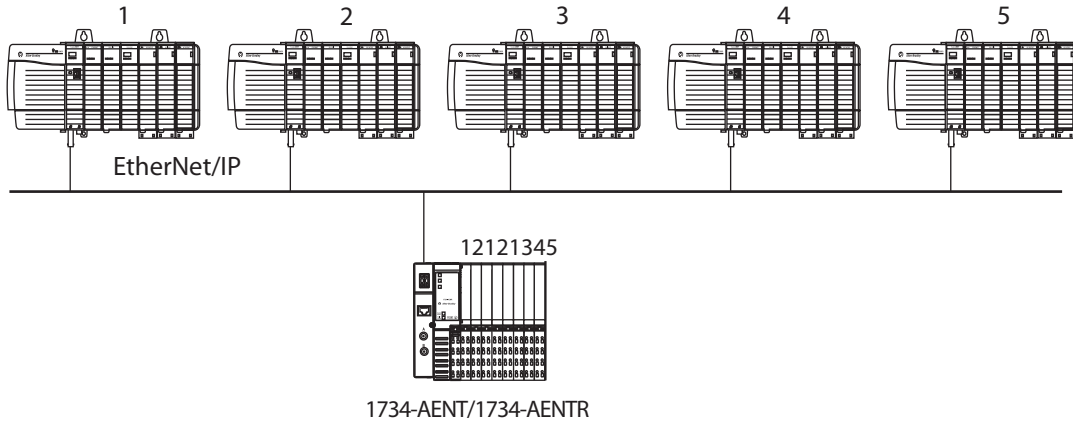

45102

1734-AENT/1734-AENTR Technical Specifications

	1734-AENT/1734-AENTR
Input Voltage, Nom.	24V DC
Input Voltage Range	10...28.8V DC
Field Side Power Requirements	400 mA @ 24V DC (+20% = 28.8V DC)
Inrush Current	6 A for 10 ms
POINTBus current (mA)	800 (1734-AENTR) 1000 (1734-AENT)
Power Consumption at 24V	4.5 W
Power dissipation, max.	2.8 W @ 28.8V
Input Overvoltage Protection	Reverse polarity protected
Interruption	Output voltage will stay within specifications when input drops out for 10 ms at 10V with max load.

ControlNet Network

The ControlNet network is an open, state-of-the-art control network that meets the demands of real-time, high-throughput applications. The ControlNet network uses the proven Common Industrial Protocol (CIP) to combine the functionality of an I/O network and a peer-to-peer network providing high-speed performance for both functions. The ControlNet network gives you deterministic, repeatable

transfers of all mission-critical control data in addition to supporting transfers of non-time-critical data.

ControlNet Network Considerations

Adapter	Considerations
1734-ACNR	<p>A total of 63 POINT I/O modules can be assembled on a single ControlNet node.</p> <p>Expansion power supplies may be used to provide additional POINTBus backplane current.</p> <p>Up to 25 direct connections and 5 rack connections are allowed.</p>

The 1734-ACNR ControlNet adapter provides high-speed transfer of time critical data between controllers and I/O devices. It manages data transfers between controllers on the ControlNet network and POINT I/O modules plugged into the POINTBus backplane. The ControlNet network allows the exchange of messages between ControlNet products compliant with the ControlNet International specification. The 1734-ACNR adapter features include a variety of control system solutions, local communication network access through the network access port (NAP), and redundant media. It requires Series C POINT I/O modules or later.

The 1734-ACNR adapter requires a typical 24V DC power supply with a maximum of 10.2 W of power. It provides a maximum backplane current of 1.0 A at 5V DC. Backplane current can be extended beyond 1.0 A with a 1734-EP24DC backplane extension power supply. The 1734-EP24DC can supply up to an additional 1.3 A of backplane current. Multiple 1734-EP24DC power supplies can be used to reach the maximum limit of 63 POINT I/O modules if 25 or fewer of these modules are analog or specialty modules.

The adapter supports 25 direct and 5 rack I/O connections to the POINT I/O modules. From a single 1734-ACNR adapter, multiple controllers establish I/O connections, up to a maximum of 5 rack I/O connections per adapter. Direct connections must be used with analog and specialty modules. Multiple rack connections permit multiple controllers to connect to I/O over a single 1734-ACNR adapter. The number of connections that can be supported on a network depends on the ControlNet parameters (NUT, RPI, and API) and the POINT I/O configuration by itself (number and types of I/O modules).

The following example shows a single POINT I/O ControlNet adapter with 5 connections and 8 I/O modules. The POINT I/O modules are monitored by the 5 controllers on the ControlNet network. The POINT I/O modules in:

- slots 1, 3, and 5 are controlled by the first controller.
- slots 2 and 4 by the second controller.
- slot 6 by the third controller.
- slot 7 by the fourth controller.

- slot 8 by the fifth controller.

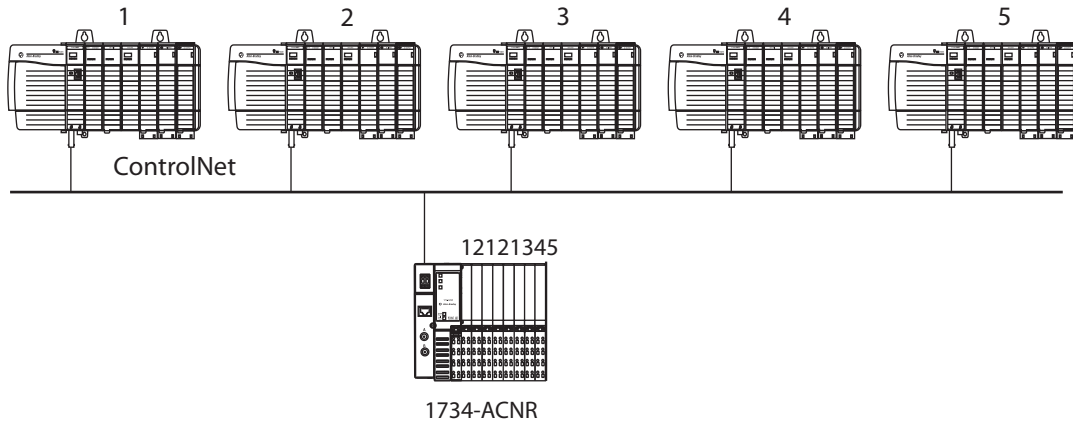

Memory Requirements

The 1734-ACNR adapter has 586 bytes of memory available for scheduled transmit data. When developing an application, the amount of data used by an individual connection must also include a small amount of overhead (I/O bytes per connection).

The following formula tracks the amount of available scheduled transmit data.

$$\text{Available Memory} = 586 - [(\text{Number of connections} * 10) + \text{Sum of all connection sizes}]$$

In the following example, the system uses a 1734-ACNR adapter with five 1734-232ASC modules.

	Application Data Size (number of bytes)	Memory Required
1734-232ASC - 1	100	110
1734-232ASC - 2	88	98
1734-232ASC - 3	96	106
1734-232ASC - 4	96	106
1734-232ASC - 5	92	102
Total Bytes Used	472	522

In this example, a sixth module could be added if it used less than 54 bytes of application data. There are 64 bytes of memory left. $64 = 586 - [(5 * 10) + 472]$

For more information about the 1734-ACNR adapter, see the POINT I/O ControlNet Adapter User Manual, publication [1734-UM008](#).

1734-ACNR Technical Specifications

	1734-ACNR
Input voltage, nom	24V DC
Input voltage range	10...28.8V DC
Field side power requirements	425 mA @ 24V DC (+20% = 28.8V DC)
Inrush current	6 A for 10 ms
POINTBus current	1000 mA ⁽¹⁾
Power consumption at 24V	8.0 W
Power dissipation, max.	2.8 W @ 28.8V
Input overvoltage protection	Reverse polarity protected
Interruption	Output voltage will stay within specifications when input drops out for 10 ms at 10V with max load.

⁽¹⁾ 1000 mA @ 5V DC \pm 5% (4.75...5.25V).

DeviceNet Network

The DeviceNet network is an open low-level network that provides connections between simple industrial devices (such as sensors and actuators) and higher-level devices (such as PLC controllers and computers). The DeviceNet network uses the proven Common Industrial Protocol (CIP) to provide the control, configure, and data collection capabilities for industrial devices. The POINT I/O family offers four interfaces for connecting to the DeviceNet network.

DeviceNet Network Considerations

Adapter	Consideration
1734-ADN	<ul style="list-style-type: none"> All POINT I/O modules count as a single node on the main network. A total of 63 POINT I/O modules can be assembled on a single DeviceNet node. Behaves as a slave device on the main network and a master on the POINTBus backplane. RSNetWorx for DeviceNet software is needed for configuration of the 1734-ADN adapter on the main network and the POINTBus backplane Expansion power supplies may be used to provide additional POINTBus backplane current.

DeviceNet Network Considerations

Adapter	Consideration
1734-ADNX	<ul style="list-style-type: none"> • Acts like a 1734-ADN adapter, with additional capabilities. • All POINT I/O modules, and some third-party field devices, count as a single node on the main network. • Has a second, Phoenix-style connector that extends the subnet off the module, so that any DeviceNet-capable device could be connected to a subnet and scanned by the 1734-ADNX adapter. • Network on the second connector is electrically isolated from the main network and can be used to extend the total DeviceNet trunk line distance.⁽¹⁾ • Node numbers of the devices on the POINTBus backplane and subnet would not count against the 63 slave nodes allowed on the main network. • Devices on the subnet and the main network need to be connected at different communication rates or use different sampling methods (for example, change-of-state or polled). • Data from these devices would be included in the data being sent to/from the 1734-ADNX adapter on the main network. • POINT I/O expansion power supplies are permitted and may be required to add more modules.
1734D POINTBlock Series	<ul style="list-style-type: none"> • Each POINT I/O module on the main network counts as a separate node. • Appears to the main network as a 1734-PDN communication interface with a single, 16-point module attached. • Any of the I/O modules may be attached in the same manner they are added to a 1734-PDN communication interface. • Total POINTBus backplane current of I/O modules cannot exceed 1.0 A. • Expansion power supplies may not be used.
1734-PDN	<ul style="list-style-type: none"> • Each POINT I/O module on the main network counts as a separate node. • Electrically connects the main network to the I/O modules, which are connected on the POINTBus backplane. • No configuration to the 1734-PDN communication interface necessary since it is transparent to the main network. • Total POINTBus backplane current of I/O modules cannot exceed 1.3 A. • Expansion power supplies may not be used.

⁽¹⁾ For example: with thick round media at 125 Kbps, you could run a maximum of 500 m (1640 ft) to a 1734-ADNX adapter on the main network. You could then wire an additional 500 m (1640 ft) of cable on the subnet connector and double the distance of the network. **Remember that this subnet needs terminating resistors and a 24V DC power connection, the same as any other DeviceNet network.**

It is important that the total amount of data coming from the subnet does not exceed the data capability of either the 1734-ADN or 1734-ADNX adapter.

- 250 bytes (248 data + 2 bytes command info) for output data (used as either COS, cyclic, or poll)
- 250 bytes (248 data + 2 bytes status info) for polled input data
- 250 bytes (248 data + 2 bytes status info) for COS/cyclic input data
- 8 bytes (6 data + 2 status info) for strobe input data

The data coming through the 1734 adapter combined with the other data from the main network cannot exceed the data capability of the

main network master scanner. If this occurs, you will need multiple master scanners on the main network and the I/O modules on the subnet will need to be split between multiple 1734-ADN or 1734-ADNX adapters.

With the 1734-PDN communication interface, the multiple masters on the main network will be able to communicate to separate groups of modules on its subnet through the same 1734-PDN communication interface, so no additional adapter would be necessary.

About the 1734D Series

The 1734D POINTBlock series is a set of DIN-rail mounted products with an integrated DeviceNet communication interface, various combinations of onboard I/O points, removable terminations, and a POINTBus expansion port.

The DeviceNet interface presents the integrated I/O as a single DeviceNet node while expansion I/O modules will appear as separate nodes.

The 1734D series includes a nonisolated DeviceNet communication interface. The 24V DC from the DeviceNet connection powers a nonisolated DC/DC converter that generates +5V DC. This +5V DC powers the 1734D series electronics and connects to the POINTBus port to power the expansion I/O electronics.

See the Select POINT I/O Modules section of this document for POINTBlock I/O module catalog numbers and specifications.

1734 DeviceNet Adapters Technical Specifications

	1734-PDN 1734D	Series	1734-ADN/X
Input voltage, nom	24V DC	10...28.8V DC	24V DC
Input voltage range	11...25V DC DeviceNet specification	11...25V DC DeviceNet specification	10...28.8V DC
Field side power requirements	400 mA @ 24V DC (+4% = 25V DC)	350 mA @ 24V DC (+4% = 25V DC)	400 mA @ 24V DC (+20% = 28.8V DC)
Inrush current	6 A for 5 ms	6 A for 5 ms	6 A for 10 ms
POINTBus current	1300 ⁽¹⁾ mA	1000 ⁽²⁾ mA	1000 mA
Power consumption at 24V	8.0 W	8.2 W	8.1 W

1734 DeviceNet Adapters Technical Specifications

	1734-PDN 1734D	Series	1734-ADN/X
Power dissipation, max.	1.2 W @ 25V	2.0 W @ 24V	2.8 W @ 28.8V
Input overvoltage protection	Reverse polarity protected		
Interruption	—	—	Output voltage will stay within specifications when input drops out for 10 ms at 10V with max load.

⁽¹⁾ 1300 mA @ 5V DC \pm 5% (4.75...5.25V).

⁽²⁾ 1000 mA @ 5V DC \pm 5% (4.75...5.25V).

PROFIBUS DP Network

PROFIBUS for Decentralized Peripherals is a standard in field bus communication in automation. that helps eliminate hard wiring, and reduces costs associated with design and installation.

PROFIBUS DP Network Considerations

Adapter	Considerations
1734-APB	A total of 63 POINT I/O modules can be assembled on a single PROFIBUS DP node. Expansion power supplies may be used to provide additional POINTBus backplane current.

Other considerations when using the APB adapter. Example, if needed (see EtherNet/IP section).

1734-APB Technical Specifications

Attribute	Value
Input voltage, nom	24V DC
Input voltage range	10...28.8V DC
Field side power requirements	400 mA @ 24V DC (+20% = 28.8V DC)
Inrush current	6 A for 10 ms
POINTBus current	1000 mA ⁽¹⁾
Power consumption at 24V	8.0 W
Power dissipation, max.	2.8 W @ 28.8V
Input overvoltage protection	Reverse polarity protected
Interruption	Output voltage will stay within specifications when input drops out for 10 ms at 10V with max load.

⁽¹⁾ 1000 mA @ 5V DC \pm 5% (4.75...5.25V).

Communication Adapter Environmental Specifications

Attribute	Value
Operating temperature	-20...55° C (-4...131° F)
Nonoperating temperature	-40...85° C (-40...185° F)
Relative humidity	5...95% noncondensing
Operating shock	30 g
Nonoperating shock	50 g
Vibration	5 g @ 10...500Hz
Enclosure type rating	None (open-style)
Mounting	DIN Rail
Certifications (when product is marked)	c-UL-us, Ex, CE , C-Tick , CI / EtherNet/IP / DeviceNet