

# PowerFlex 750-Series Safe Torque Off

Catalog Number 20-750-S



Original Instructions

## Important User Information

Read this document and the documents listed in the additional resources section about installation, configuration, and operation of this equipment before you install, configure, operate, or maintain this product. Users are required to familiarize themselves with installation and wiring instructions in addition to requirements of all applicable codes, laws, and standards.

Activities including installation, adjustments, putting into service, use, assembly, disassembly, and maintenance are required to be carried out by suitably trained personnel in accordance with applicable code of practice.

If this equipment is used in a manner not specified by the manufacturer, the protection provided by the equipment may be impaired.

In no event will Rockwell Automation, Inc. be responsible or liable for indirect or consequential damages resulting from the use or application of this equipment.

The examples and diagrams in this manual are included solely for illustrative purposes. Because of the many variables and requirements associated with any particular installation, Rockwell Automation, Inc. cannot assume responsibility or liability for actual use based on the examples and diagrams.

No patent liability is assumed by Rockwell Automation, Inc. with respect to use of information, circuits, equipment, or software described in this manual.

Reproduction of the contents of this manual, in whole or in part, without written permission of Rockwell Automation, Inc., is prohibited.

Throughout this manual, when necessary, we use notes to make you aware of safety considerations.



**WARNING:** Identifies information about practices or circumstances that can cause an explosion in a hazardous environment, which may lead to personal injury or death, property damage, or economic loss.



**ATTENTION:** Identifies information about practices or circumstances that can lead to personal injury or death, property damage, or economic loss. Attentions help you identify a hazard, avoid a hazard, and recognize the consequence.

---

### IMPORTANT

Identifies information that is critical for successful application and understanding of the product.

---

Labels may also be on or inside the equipment to provide specific precautions.



**SHOCK HAZARD:** Labels may be on or inside the equipment, for example, a drive or motor, to alert people that dangerous voltage may be present.



**BURN HAZARD:** Labels may be on or inside the equipment, for example, a drive or motor, to alert people that surfaces may reach dangerous temperatures.



**ARC FLASH HAZARD:** Labels may be on or inside the equipment, for example, a motor control center, to alert people to potential Arc Flash. Arc Flash will cause severe injury or death. Wear proper Personal Protective Equipment (PPE). Follow ALL Regulatory requirements for safe work practices and for Personal Protective Equipment (PPE).

---

This manual contains new and updated information.

### New and Updated Information

This table contains the changes made to this revision.

| Topic  | Page   |
|--|--|
| Revised Environmental Specifications to include 477 A rating.                                | <a href="#">34</a>   |
| Revised figures in Chapter 4 to show SP- and SE- wired to the external power supply +24V DC. | <a href="#">29</a> , <a href="#">30</a> , <a href="#">31</a> |

**Notes:**

|  |  |    |
|--|--|----|
|  | <b>Chapter 1</b>   |    |
| <b>Safe Torque Off Option Overview</b>         | What Is the PowerFlex 750-Series Safe Torque Off Option? . . . . . | 7  |
|  | Safety Standards Applied To Safe Torque Off Option . . . . .       | 8  |
|  | <b>Chapter 2</b>   |    |
| <b>Safety Concept</b>                          | Introduction . . . . .   | 9  |
|  | Safety Certification . . . . .                                     | 9  |
|  | Functional Proof Tests . . . . .                                   | 11 |
|  | PFD and PFH Definitions . . . . .                                  | 11 |
|  | PFD and PFH Data . . . . .   | 12 |
|  | Safe State . . . . .   | 12 |
|  | Safety Reaction Time . . . . .                                     | 12 |
|  | Considerations for Safety Ratings . . . . .                        | 13 |
|  | Contact Information if Safety Option Failure Occurs . . . . .      | 13 |
|  | <b>Chapter 3</b>   |    |
| <b>Installation and Wiring</b>                 | Access Drive Control Pod . . . . .                                 | 16 |
|  | Configure Safety Enable . . . . .                                  | 20 |
|  | Option Module Installation . . . . .                               | 23 |
|  | Wiring . . . . .   | 24 |
|  | Verify Operation . . . . .   | 25 |
|  | <b>Chapter 4</b>   |    |
| <b>Safe Torque Off Option Module Operation</b> | PowerFlex 750-Series Safe Torque Off Operation . . . . .           | 27 |
|  | <b>Appendix A</b>  |    |
| <b>Specifications</b>                          | Introduction . . . . .   | 33 |
|  | General Specifications . . . . .                                   | 33 |
|  | Environmental Specifications . . . . .                             | 34 |
|  | Certifications . . . . .   | 35 |
|  | CE Conformity . . . . .  | 35 |

**Notes:**

---

## Safe Torque Off Option Overview

The Safe Torque Off option is just one component in a safety control system. Components in the system must be chosen and applied appropriately to achieve the desired level of operational safety.

### What Is the PowerFlex 750-Series Safe Torque Off Option?

The PowerFlex 750-Series Safe Torque Off option:

- Is designed to help safely remove power from the gate firing circuits of the drive's output power devices (IGBT's). This helps prevent the drive's output power devices from switching in the pattern necessary to generate AC power to the motor.
- Can be used in combination with other safety devices to satisfy the requirements of IEC 61508, IEC 61800-5-2 SIL 3, ISO 13849-1 PL e, and Category 3 for Safe Torque Off (STO).

---

**IMPORTANT** This option is suitable for performing mechanical work on the drive system or affected area of a machine only. It does not provide electrical safety. This option should not be used as a control for starting and/or stopping the drive.

---



**ATTENTION:** Electrical Shock Hazard. Verify that all sources of AC and DC power are deenergized and locked out or tagged out in accordance with the requirements of ANSI/NFPA 70E, Part II.



**ATTENTION:** To avoid an electric shock hazard, verify that the voltage on the bus capacitors has discharged before performing any work on the drive. Measure the DC bus voltage at the +DC and -DC terminals or test points (refer to your drive's User Manual for locations). The voltage must be zero.



**ATTENTION:** In safe-off mode, hazardous voltages may still be present at the motor. To avoid an electric shock hazard, disconnect power to the motor and verify that the voltage is zero before performing any work on the motor.



**ATTENTION:** In the event of the failure of two output IGBTs in the drive, when the PowerFlex 750-Series Safe Torque Off option has controlled the drive outputs to the off state, the drive may provide energy for up to 180° of rotation in a 2-pole motor before torque production in the motor ceases.

---

## **Safety Standards Applied To Safe Torque Off Option**

The Safe Torque Off option satisfies applicable requirements in the following standards related to functional and machinery safety.

- IEC 61508: 2010 SIL 3
- EN 61800-5-2: 2007 SIL 3
- EN 61800-3: 2004 + A1:2012
- EN 62061: 2005 + A1:2013
- EN ISO 13849-1: 2008 Performance Level e, Category 3
- EN 60204-1: 2006 + A1:2009
- NFPA 79: 2007



## Safety Concept

### Introduction

This section describes the safety performance level concept and how the PowerFlex 750-Series drives can meet the requirements for SIL CL3, CAT 3, or PL e applications.

### Safety Certification

The PowerFlex 750-Series safety option is certified for use in safety applications up to and including SIL 3 according to EN 61800-5-2, IEC 61508, and EN 62061, Performance Level PL e and Category 3 according to EN ISO 3849-1. Safety requirements are based on the standards current at the time of certification.

The TÜV Rheinland group has approved the PowerFlex 750-Series safety option for use in safety-related applications where the de-energized state is considered to be the safe state. All of the examples in this manual are based on achieving de-energization as the safe state for typical Machine Safety and Emergency Shutdown (ESD) systems.

### Important Safety Considerations

The system user is responsible for:

- the set-up, safety rating, and validation of any sensors or actuators connected to the system.
- completing a system-level risk assessment and reassessing the system any time a change is made.
- certification of the system to the desired safety performance level.
- project management and proof testing.
- programming the application software and the safety option configurations in accordance with the information in this manual.
- access control to the system.
- analyzing all configuration settings and choosing the proper setting to achieve the required safety rating.

---

**IMPORTANT** When applying Functional Safety, restrict access to qualified, authorized personnel who are trained and experienced.

---



**ATTENTION:** When designing your system, consider how personnel will exit the machine if the door locks while they are in the machine. Additional safeguarding devices may be required for your specific application.

---

## Safety Category 3 Performance Definition

To achieve Safety Category 3 according to EN ISO 13849-1:2008, the safety-related parts have to be designed such that:

- the safety-related parts of machine control systems and/or their protective equipment, as well as their components, shall be designed, constructed, selected, assembled, and combined in accordance with relevant standards so that they can withstand expected conditions.
- basic safety principles shall be applied.
- a single fault in any of its parts does not lead to a loss of safety function.
- the average diagnostic coverage of the safety-related parts of the control system shall be medium.
- the mean time to dangerous failure of each of the redundant channels shall be high.
- measures against common cause failure shall be applied.

## Stop Category Definitions

The selection of a stop category for each stop function must be determined by a risk assessment.

- Stop Category 0 is achieved with immediate removal of power to the actuator, resulting in an uncontrolled coast to stop. Safe Torque Off accomplishes a Stop Category 0 stop.
- Stop Category 1 is achieved with power available to the machine actuators to achieve the stop. Power is removed from the actuators when the stop is achieved.

---

**IMPORTANT** When designing the machine application, timing and distance should be considered for a coast to stop (Stop Category 0 or Safe Torque Off). For more information regarding stop categories, refer to EN 60204-1.

---

## Performance Level and Safety Integrity Level (SIL) CL3

For safety-related control systems, Performance Level (PL), according to ISO 13849-1, and SIL levels, according to IEC 61508 and EN 62061, include a rating of the system's ability to perform its safety functions. All of the safety-related components of the control system must be included in both a risk assessment and the determination of the achieved levels.

Refer to the ISO 13849-1, IEC 61508, and EN 62061 standards for complete information on requirements for PL and SIL determination.

## Functional Proof Tests

The functional safety standards require that functional proof tests be performed on the equipment used in the system. Proof tests are performed at user-defined intervals and are dependent upon PFD and PFH values.

---

**IMPORTANT** Your specific application determines the time frame for the proof test interval.

---

## PFD and PFH Definitions

Safety-related systems can be classified as operating in either a Low Demand mode, or in a High Demand/Continuous mode.

- Low Demand mode: where the frequency of demands for operation made on a safety-related system is no greater than one per year or no greater than twice the proof-test frequency.
- High Demand/Continuous mode: where the frequency of demands for operation made on a safety-related system is greater than once per year or greater than twice the proof test interval.

The SIL value for a low demand safety-related system is directly related to order-of-magnitude ranges of its average probability of failure to satisfactorily perform its safety function on demand or, simply, average probability of failure on demand (PFD). The SIL value for a High Demand/continuous mode safety-related system is directly related to the probability of a dangerous failure occurring per hour (PFH).

## PFD and PFH Data

PFD and PFH calculations are based on the equations from Part 6 of IEC 61508.

This table provides data for a 20-year proof test interval and demonstrates the worst-case effect of various configuration changes on the data.

### PFD and PFH for 20-year Proof Test Interval

| Attribute                 | Value              |                |                |                |
|---------------------------|--------------------|----------------|----------------|----------------|
|                           | Drive Frames 1...7 | Drive Frame 8  | Drive Frame 9  | Drive Frame 10 |
| PFD                       | 3.29E-5            | 1.73E-04       | 2.65E-4        | 3.56E-4        |
| PFH                       | 3.75E-10 1/hour    | 1.99E-9 1/hour | 3.04E-9 1/hour | 4.09E-9 1/hour |
| SIL CL                    | 3                  | 3              | 3              | 3              |
| PL                        | e                  | e              | e              | e              |
| Category                  | 3                  | 3              | 3              | 3              |
| HFT                       | 1 (1002)           | 1 (1002)       | 1 (1002)       | 1 (1002)       |
| PTI (Proof Test Interval) | 20 years           | 20 years       | 20 years       | 20 years       |

## Safe State

The Safe State encompasses all operation that occurs outside of the other monitoring and stopping behavior defined as part of the Safe Torque Off Option module.

If a Safe State Fault is detected, the safety option goes to the Safe State. This includes faults related to integrity of hardware or firmware.

## Safety Reaction Time

The safety reaction time is the amount of time from a safety-related event as input to the system until the system is in the Safe State.

The safety reaction time from an input signal condition that triggers a safe stop, to the initiation of the configured Stop Type, is 10 ms (maximum) for drive Frames 1...10.

---

**IMPORTANT** An input signal condition that is present for less than the reaction time may not result in the safety function being performed. Repeated request of the safety function for less than the reaction time may result in a spurious detection of a fault.

---

## **Considerations for Safety Ratings**

The achievable safety rating of an application using the safety option installed in PowerFlex 750-Series drives is dependent upon many factors, drive options, and the type of motor.

For applications that rely on the immediate removal of power to the actuator, resulting in an uncontrolled coast to stop, a safety rating up to and including SIL CL3, PL e, and Category 3 can be achieved.

## **Contact Information if Safety Option Failure Occurs**

If you experience a failure with any safety-certified device, contact your local Rockwell Automation distributor. With this contact, you can:

- return the device to Rockwell Automation so the failure is appropriately logged for the catalog number affected and a record is made of the failure.
- request a failure analysis (if necessary) to determine the probable cause of the failure.

**Notes:**

## Installation and Wiring

Installation must be in accordance with the following steps and must be carried out by competent personnel. The Safe Torque Off option is intended to be part of the safety related control system of a machine. Before installation, a risk assessment should be performed that compares the Safe Torque Off option specifications and all foreseeable operational and environmental characteristics of the machine to which it is to be fitted.

A safety analysis of the machine section controlled by the drive is required to determine how often the safety function should be tested for proper operation during the life of the machine.



**ATTENTION:** The following information is merely a guide for proper installation. Rockwell Automation, Inc. cannot assume responsibility for the compliance or the noncompliance to any code, national, local or otherwise for the proper installation of this equipment. A hazard of personal injury and/or equipment damage exists if codes are ignored during installation.

---

## Access Drive Control Pod

1. Remove drive cover.

Frames 1...5

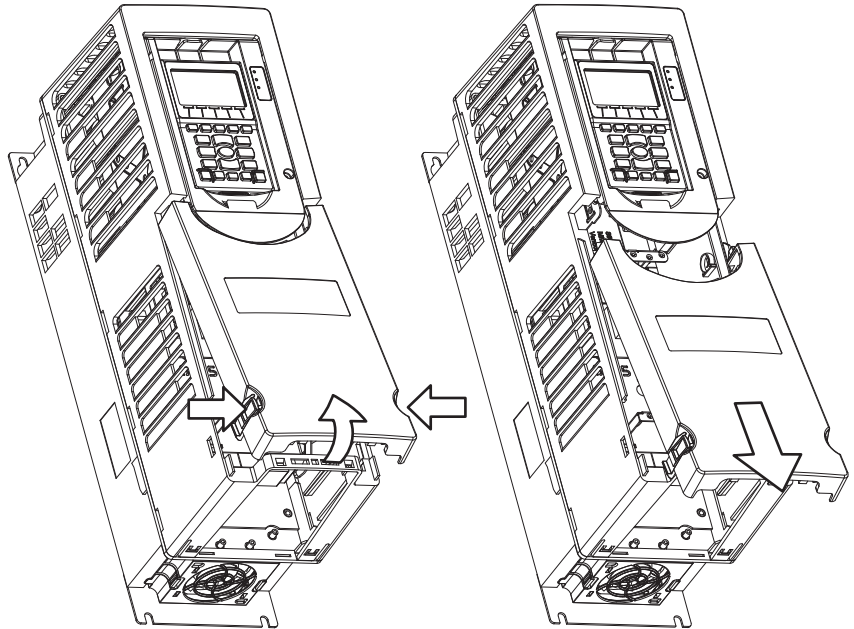

- Squeeze locking tabs and pull out bottom of cover.
- Pull cover down and away from the chassis

Frames 6...7

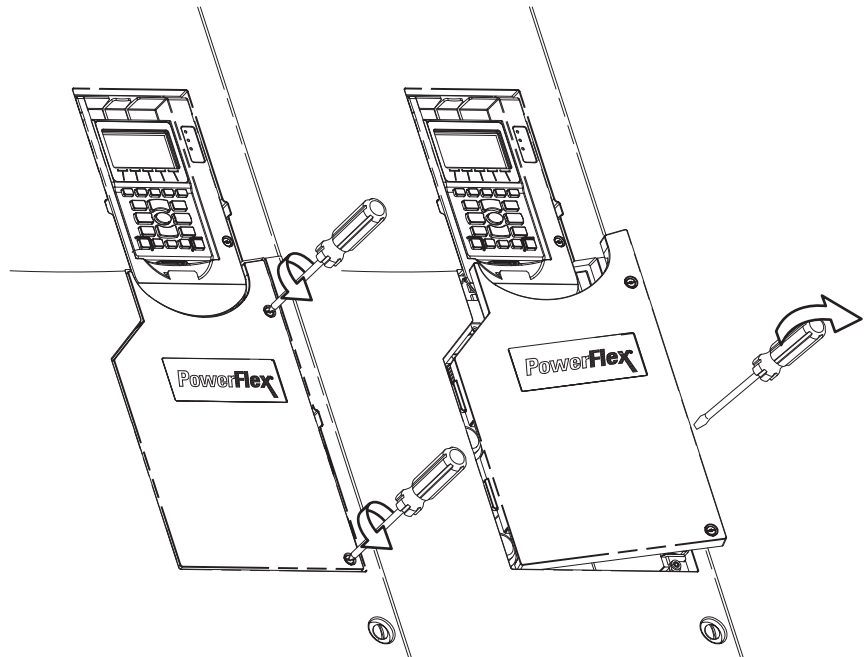

- Loosen door screws.
- Gently pry the door open to remove.



## Frames 8...10

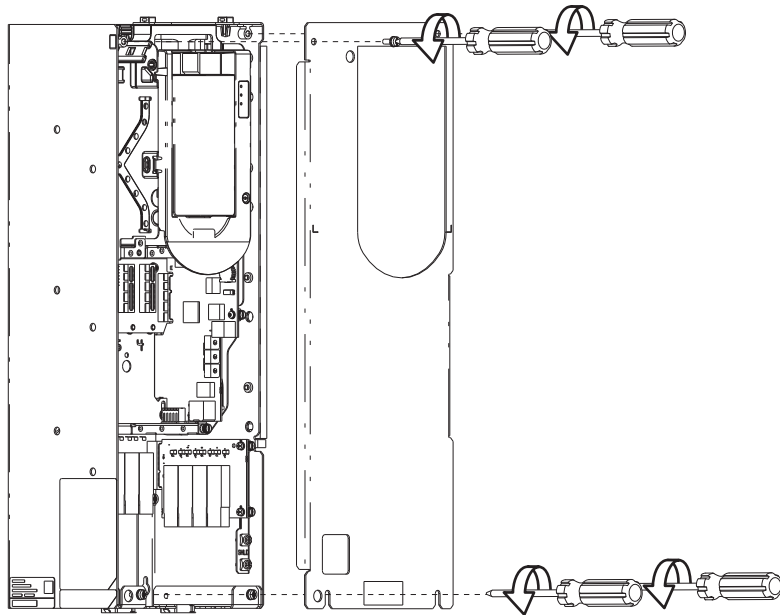

- Remove top screws.
- Loosen bottom screws.
- Remove the right front cover.

2. Frame 1 – Lift the chassis cover.  
Frames 2...7 – Lift the Human Interface Module (HIM) cradle.

Frame 1

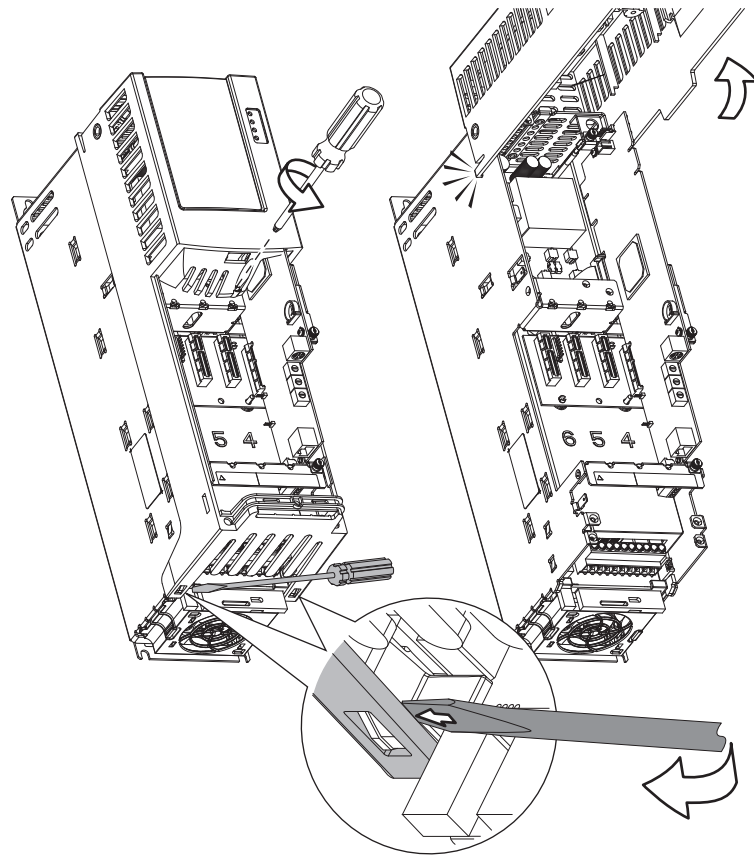

- Loosen the retention screw.
- Use a screwdriver to release the chassis cover locking tabs.
- Lift the chassis until the latch engages.

Frames 2...7

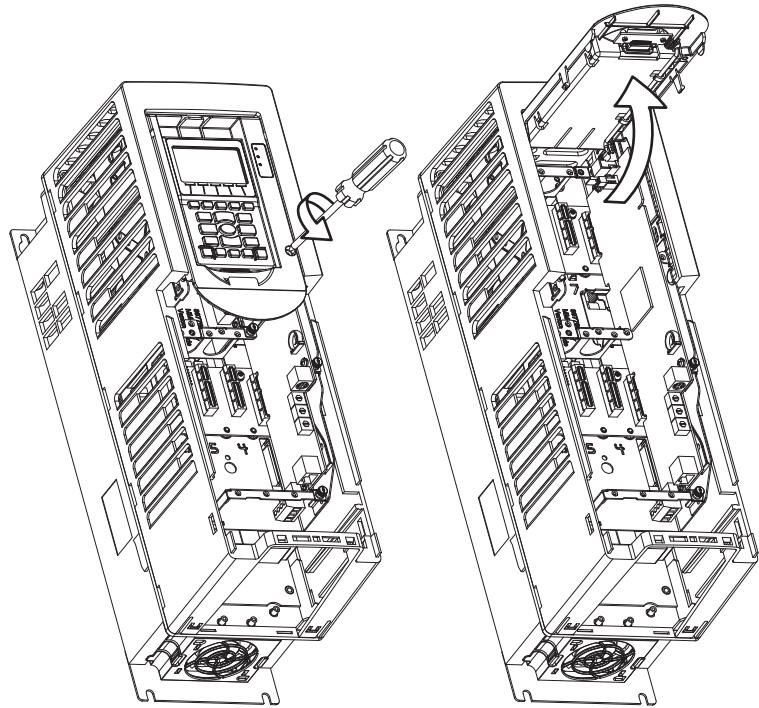

- Loosen the retention screw.
- Lift the cradle until the latch engages.

Frames 8...10

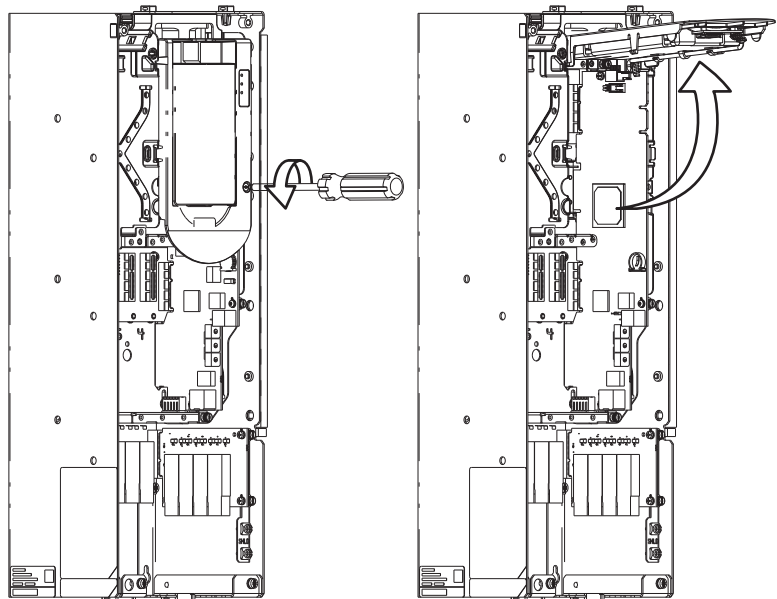

- Loosen the retention screw.
- Lift the cradle until the latch engages.

## Configure Safety Enable

### Safety Enable Jumper

When installing the Safe Torque Off option module, ensure the safety enable jumper (SAFETY) on the Main Control Board is removed.

#### *PowerFlex 753 - SAFETY Jumper Location*

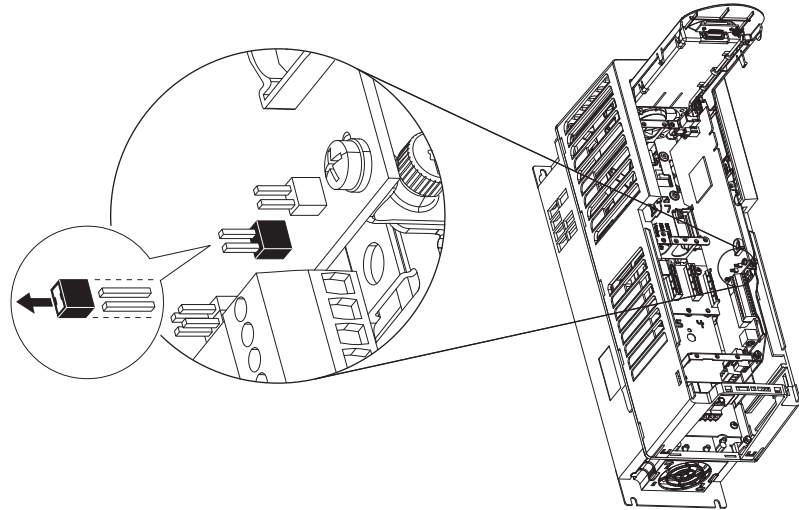

#### *PowerFlex 755 - SAFETY Jumper Location (Frames 1...7 Only)*

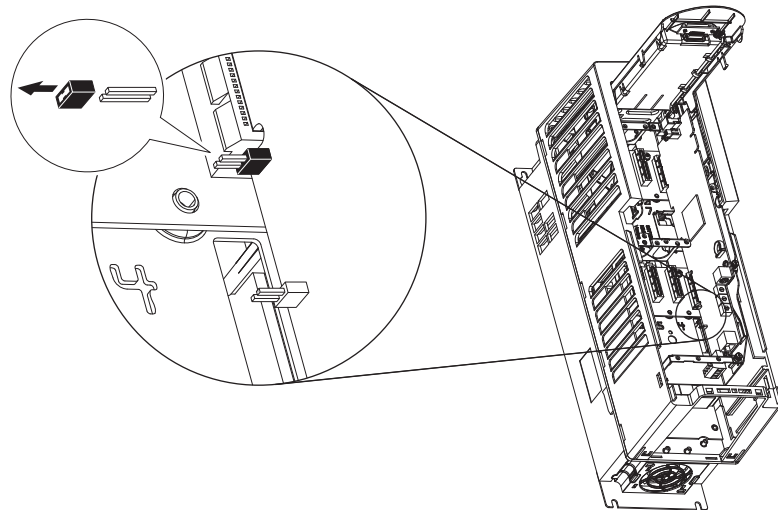

**Note:** Frame 8...10 drives do not have a safety enable jumper.

## Hardware Enable Jumper

When installing the Safe Torque Off option module, ensure the hardware enable jumper (ENABLE) on the Main Control Board is installed.

### *PowerFlex 753 - ENABLE Jumper Location*

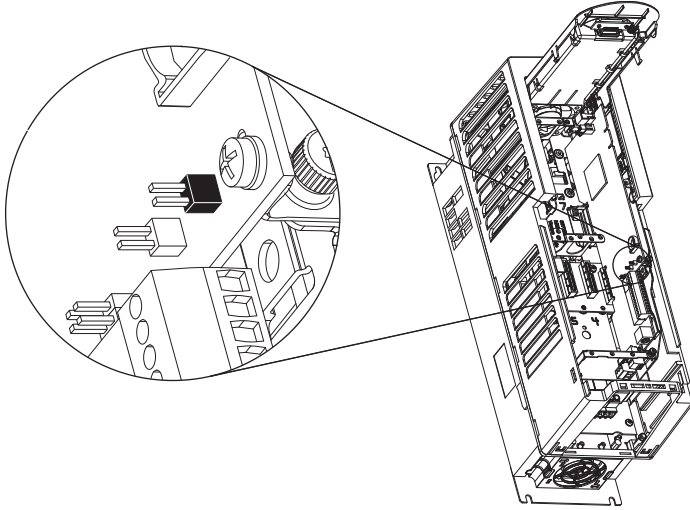

### *PowerFlex 755 - ENABLE Jumper Location (Frames 1...7)*

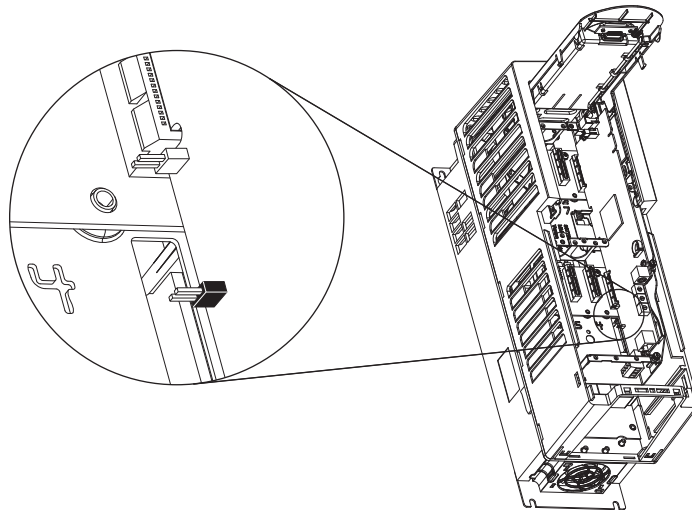

*PowerFlex 755 - ENABLE Jumper Location (Frames 8...10)*

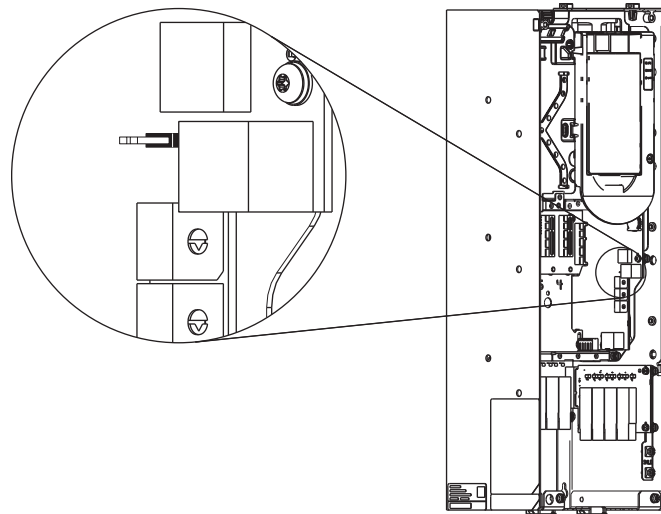

## Option Module Installation



**ATTENTION:** Hazard of equipment damage exists if an option module is installed or removed while the drive is powered. To avoid damaging the drive, verify that the voltage on the bus capacitors has discharged before performing any work on the drive.

**Frames 1...7:** Measure the DC bus voltage at the Power Terminal Block by measuring between the +DC and -DC terminals, between the +DC terminal and the chassis, and between the -DC terminal and the chassis. The voltage must be zero for all three measurements.

**Frames 8...10:** Measure the DC bus voltage at the DC+ and DC- TESTPOINT sockets on the front of the power module.

To install the Safe Torque Off option module:

1. Firmly press the module edge connector into the desired port.

**IMPORTANT** The Safe Torque Off option module can be installed in any drive port. However, when used in an Integrated Motion application, the module must be installed in port 6.

2. Tighten the top and bottom retaining screws.
  - Recommended torque = 0.45 N•m (4.0 lb•in)
  - Recommended screwdriver = T15 Hexalobular



**IMPORTANT** Do not over-tighten retaining screws.

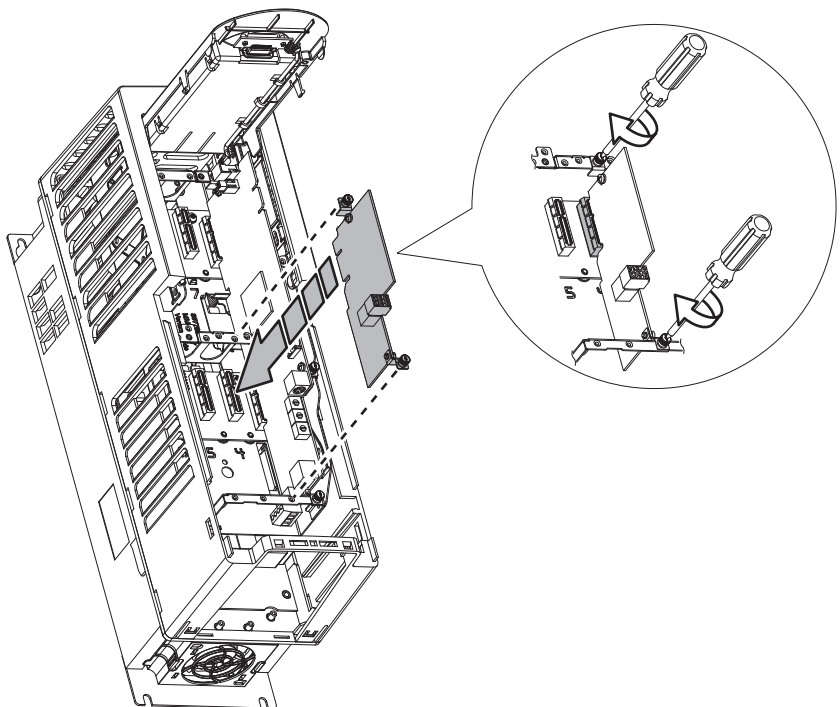

## Wiring

Important points to remember about wiring:

- Always use tinned copper wire.
- Wire with an insulation rating of 600V or greater is recommended.
- Control wires should be separated from power wires by at least 0.3 meters (1 foot).

**Table 1 - Safe Torque Off Option Terminal Block Specifications**

| Wire Size Range                 |                                 | Wire Type                      | Strip Length        |
|---------------------------------|---------------------------------|--------------------------------|---------------------|
| Maximum                         | Minimum                         |                                |                     |
| 0.8 mm <sup>2</sup><br>(18 AWG) | 0.3 mm <sup>2</sup><br>(28 AWG) | Multi-conductor shielded cable | 10 mm<br>(0.39 in.) |

**Table 2 - TB2 Terminal Designations**

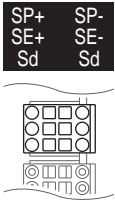
|   | Terminal | Name                   | Description   |
|---|----------|------------------------|---|
|  | SP+      | +24 Volt Safety Power  | User-supplied power: 24 volt ±10%<br>45 mA typical                                      |
|   | SP-      | Safety Power Common    |   |
|   | SE+      | +24 Volt Safety Enable | User-supplied power: 24 volt ±10%<br>25 mA typical                                      |
|   | SE-      | Safety Enable Common   |   |
|   | Sd       | Shield                 | Terminating point for wiring shields when an EMC plate or conduit box is not installed. |
|   | Sd       | Shield                 |   |

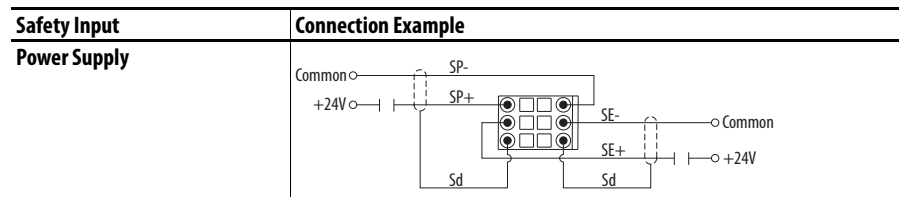
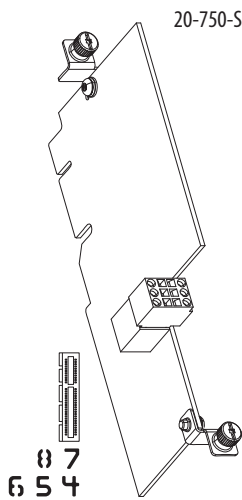

### Important Safe Torque Off Option Module Installation Notes

#### Cabling

- Safety input wiring must be protected against external damage by cable ducting, conduit, armored cable or other means.
- Shielded cable is required.

#### Power Supply Requirements

- The external power supply must conform to the Directive 2006/95/EC Low Voltage, by applying the requirements of EN61131-2 Programmable Controllers, Part 2 - Equipment Requirements and Tests and one of the following:
  - EN60950 - SELV (Safety Extra Low Voltage)
  - EN60204 - PELV (Protective Extra Low Voltage)
  - IEC 60536 Safety Class III (SELV or PELV)
  - UL 508 Limited Voltage Circuit
  - 24V DC ±10% must be supplied by a power supply that complies with IEC 60204 and IEC 61558-1.
- For planning information, refer to the guidelines in Industrial Automation Wiring and Grounding Guidelines, publication [1770-4.1](#).



**Port Assignment**

- When used in an Integrated Motion application, the Safe Torque Off option must be installed in port 6.
- Only one safety option module can be installed at a time. Multiple safety options or duplicate safety option installations are not supported.

**Jumper Settings**

- Ensure the hardware enable jumper (ENABLE) on the main control board is installed. Refer to [page 21](#) for location. If not installed, the drive will fault when powered up.
- Ensure the safety enable jumper (SAFETY) on the main control board is removed (Frames 1...7 only). Refer to [page 20](#) for location.

**Verify Operation**

Test the safety function for proper operation after initial installation of the Safe Torque Off option module. Retest the safety function at the intervals determined by the safety analysis described on [page 15](#).

Verify that both safety channels are functioning according to [Table 3](#).

**Table 3 - Channel Operation and Verification**

| Safety Function Status  | Drive In Not Enabled State | Drive In Not Enabled State | Drive In Not Enabled State | Drive Able To Run (Ready) |
|---|----------------------------|----------------------------|----------------------------|---------------------------|
| <b>Safety Channel Operation</b>   |                            |                            |                            |                           |
| <b>Safe Torque Off Option</b><br>Terminals SP+ & SP-<br>(Safety Power)  | No Power Applied           | Power Applied              | No Power Applied           | Power Applied             |
| <b>Safe Torque Off Option</b><br>Terminals SE+ & SE-<br>(Safety Enable) | No Power Applied           | No Power Applied           | Power Applied              | Power Applied             |

**IMPORTANT** If an external fault is present on the wiring or circuitry controlling the Safety Enable or Safety Power inputs for a period of time, the Safe Torque Off option will not detect this condition. When the external fault condition is removed the Safe Torque Off option will allow an enable condition.

To achieve maximum safety rating, both safety inputs SP and SE must be activated by appropriate dual channel equipment. The repeated activation of the safety function by only one input at a time may result in a spurious detection of a fault.

**TIP** No tell back contact for status is provided on the Safe Torque Off option.

**Notes:**

---

## Safe Torque Off Option Module Operation

### PowerFlex 750-Series Safe Torque Off Operation

The PowerFlex 750-Series Safe Torque Off option module (see [Figure 1](#)) disables the drive's output IGBT's by either disconnecting the power supply to the gate control driver IC or disabling the output of the gate control driver IC. The system satisfies the requirements of SIL3 for safe turn off of torque.

---

**IMPORTANT** The Safe Torque Off option does not eliminate dangerous voltages at the drive output. Input power to the drive must be turned off and safety procedures followed before performing any electrical work on the drive or motor.

---



**ATTENTION:** In the event of the failure of two output IGBTs in the drive, when the PowerFlex 750-Series Safe Torque Off option has controlled the drive outputs to the off state, the drive may provide energy for up to 180° of rotation in a 2-pole motor before torque production in the motor ceases.

---

Under normal operation, 24V DC is applied to both the Safety Power and Safety Enable inputs of the Safe Torque Off option module. If the Safety Enable or Safety Power is de-energized, the outputs of the gate control driver IC are disabled and IGBT firing is disabled. Parameter 933 [Start Inhibits] will indicate that IGBTs are inhibited and the HIM will indicate that the drive is not enabled.



**ATTENTION:** By itself, the PowerFlex 750-Series Safe Torque Off option initiates a coast-to-stop action. Additional protective measures will need to be applied when an application requires a different stopping action.

---

Figure 1 - Drive Safe Torque Off Circuitry

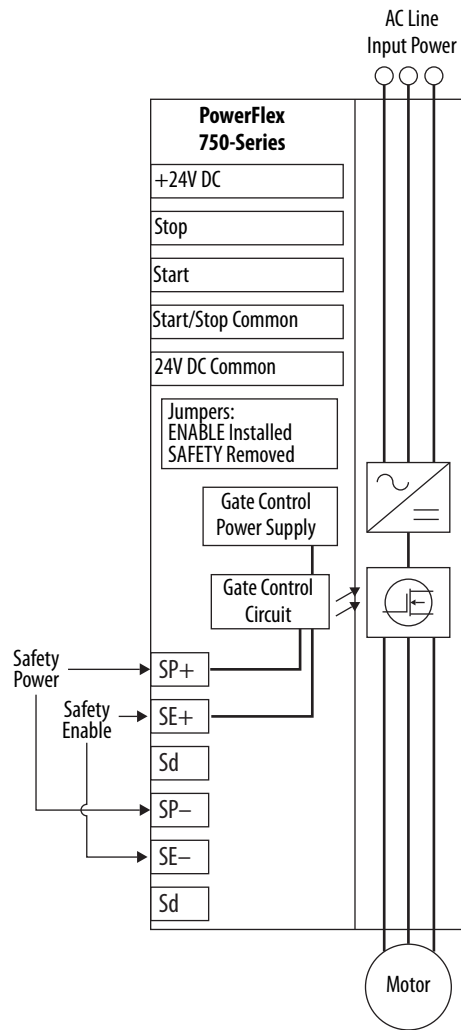

## Example 1 - PowerFlex 750-Series Drives, Frames 1...10 Safe Torque Off Connection with Coast-to-Stop Action, Dual Channel

Figure 2 - Stop Category 0 – Coast

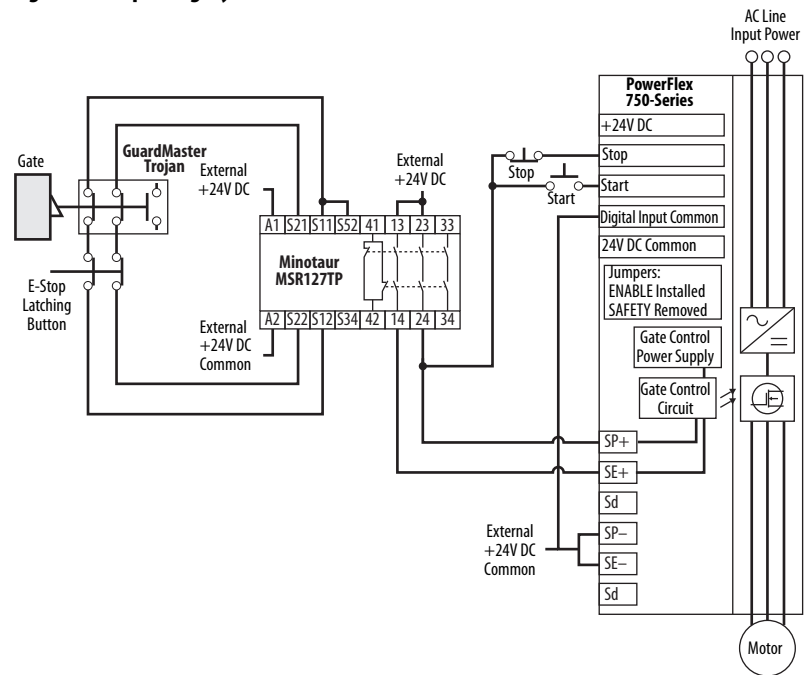

### Circuit Status

Circuit shown with guard door closed and system ready for normal drive operation.

### Operating Principle

This is a dual channel system with monitoring of the Safe Torque Off circuit and drive. Opening the guard door will switch the input circuits (S11-S12 & S21-S22) to the Minotaur monitoring safety relay unit. The output circuits (13-14 & 23-24) will cause the Safe Torque Off option and drive Enable circuit to trip and the motor will coast to stop. To restart the drive, the Minotaur safety relay must first be reset followed by a valid start command to the drive.

### Fault Detection

A single fault detected on the Minotaur safety input circuits will result in the lock-out of the system at the next operation and will not cause loss of the safety function.

## Example 2 - PowerFlex 750-Series Drives, Frames 1...10 Safe Torque Off Connection with Coast-to-Stop Action, Dual Channel

Figure 3 - Stop Category 0 – Coast

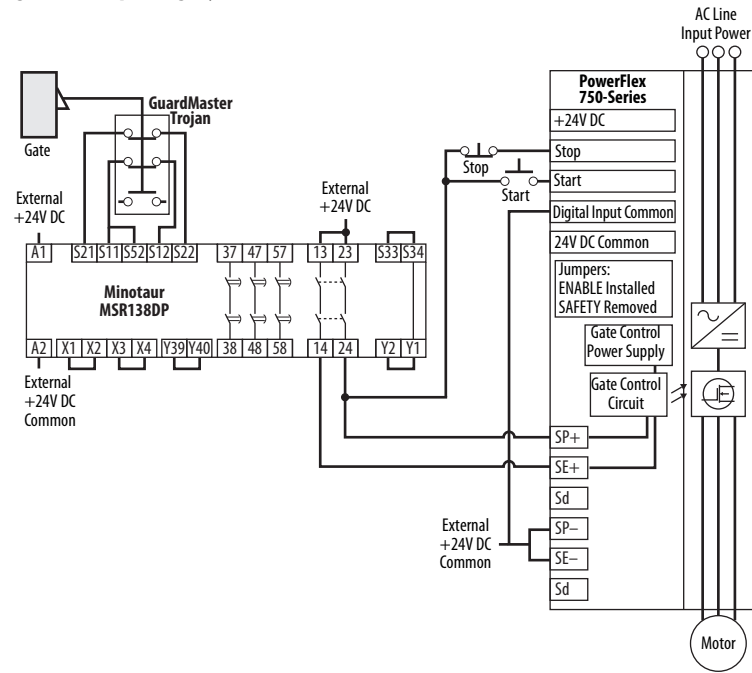

### Circuit Status

Circuit shown with guard door closed and system ready for normal drive operation.

### Operating Principle

This is a dual channel system with monitoring of the Safe Torque Off circuit and drive. Opening the guard door will switch the input circuits (S11-S12 & S21-S22) to the Minotaur monitoring safety relay unit. The output circuits (13-14 & 23-24) cause the drive Enable circuit to trip and the motor will coast to stop. To restart the drive, the Minotaur safety relay must first be reset followed by a valid start command to the drive.

### Application Considerations

When the hazard analysis for the overall machine determines the need for external mechanical brakes or other stopping means, the external means shall be activated after the removal of power for Stop Category 0.

If the Safe Torque Off option sticks ON, the motor will stop on command due to the enable input. The system cannot be reset when this fault condition exists.

### Example 3 - All Drives Safe Torque Off Connection with Controlled Stop Action, Dual Channel

Figure 4 - Stop Category 1 – Controlled

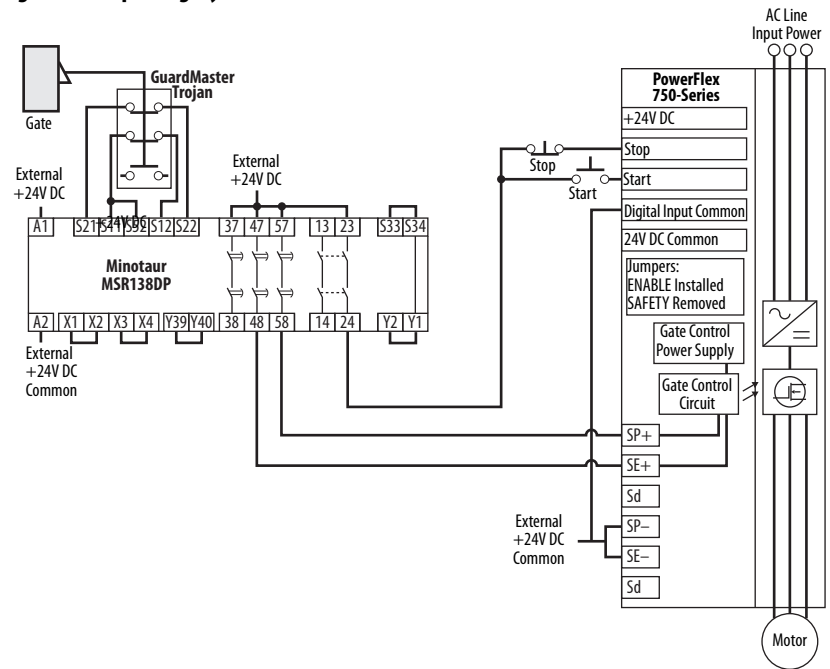

#### *Circuit Status*

Circuit shown with guard door closed and system ready for normal operation.

#### *Operating Principle*

This is a dual channel system with monitoring of the Safe Torque Off circuit and drive. Opening the guard door will switch the input circuits (S11-S12 & S21-S22) to the Minotaur monitoring safety relay unit. The output circuits (23-24) will issue a Stop command to the drive and cause a controlled deceleration. After the programmed delay, the timed output circuits (47-48 & 57-58) will cause the Safe Torque Off option and the drive Enable circuit to trip. If the motor is rotating when the trip occurs, it will coast to stop. To restart the drive, the Minotaur safety relay must first be reset followed by a valid start command to the drive.

#### *Fault Detection*

A single fault detected on the Minotaur safety input circuits will result in the lock-out of the system at the next operation and will not cause loss of the safety function.

If the Safe Torque Off option sticks ON, the motor will stop on command due to the enable input. The system cannot be reset when this fault condition exists.

**Notes:**



## Specifications

### Introduction

This appendix provides general specifications for the Safe Torque Off Option module.

### General Specifications

| Attribute                     | Value   |
|-------------------------------|---|
| Standards                     | EN 60204-1, IEC 61508, EN 61800-3, EN 61800-5-1, EN 61800-5-2, EN 62061, EN ISO 13489 |
| Safety category               | Cat. 3 and PL e per ISO 13849-1; SIL CL3 per IEC 61508 and EN 62061                   |
| Power supply (user I/O)       | 24V DC $\pm 10\%$ , 0.8 . . . 1.1 x rated voltage <sup>(1)</sup> PELV or SELV         |
| Power consumption             | 4.4 watts   |
| Safety enable SE+, SE-        | 24V DC, 25 mA   |
| Safety power SP+, SP-         | 24V DC, 45 mA   |
| Input ON Voltage, min         | 24V DC $\pm 10\%$ , 21.6 . . . 26.4V DC   |
| Input OFF Voltage, max        | 5V  |
| Input OFF Current, max        | 2.5 mA @ 5V DC  |
| Conductor type                | Multi-conductor shielded cable  |
| Conductor size <sup>(2)</sup> | 0.3 . . . 0.8 mm <sup>2</sup> (28 . . . 18 AWG)                                       |
| Strip length                  | 10 mm (0.39 in.)  |

(1) Safety outputs need additional fuse for reverse voltage protection of the control circuit. Install a 6 A slow-blow or 10 A fast-acting fuse.

(2) Refer to Industrial Automation Wiring and Grounding Guidelines, publication 1770-4.1.

## Environmental Specifications

| Category  | Specification  |                |                          |   |         |   |      |    |      |    |       |    |       |     |         |
|---|--|----------------|--------------------------|---|---------|---|------|----|------|----|-------|----|-------|-----|---------|
| Maximum Surrounding Air Temperature                     |  |                |                          |   |         |   |      |    |      |    |       |    |       |     |         |
| IP20, NEMA/UL Open Type                                 | 0...50 °C (32...122 °F) Frame 1...5, All Ratings   |                |                          |   |         |   |      |    |      |    |       |    |       |     |         |
| IP00, NEMA/UL Open Type                                 | 0...50 °C (32...122 °F) Frame 6...7, 12...456 A Ratings  |                |                          |   |         |   |      |    |      |    |       |    |       |     |         |
| IP20, NEMA/UL Type 1 (w/Hood)                           | 0...40 °C (32...104 °F) Frame 7, 477 A Rating  |                |                          |   |         |   |      |    |      |    |       |    |       |     |         |
| IP20, NEMA/UL Type 1 (w/Label)                          | 0...40 °C (32...104 °F) Frame 1...5, All Ratings   |                |                          |   |         |   |      |    |      |    |       |    |       |     |         |
| IP20, NEMA/UL Type 1                                    | 0...40 °C (32...104 °F) <sup>(1)</sup> Frame 6...7, All Ratings  |                |                          |   |         |   |      |    |      |    |       |    |       |     |         |
| IP00, NEMA/UL Open Type                                 | 0...40 °C (32...104 °F) <sup>(1)</sup> Frame 8...10, All Ratings   |                |                          |   |         |   |      |    |      |    |       |    |       |     |         |
| IP54, NEMA 12   | 0...40 °C (32...104 °F) <sup>(1)</sup> Frame 8...10, All Ratings   |                |                          |   |         |   |      |    |      |    |       |    |       |     |         |
| Flange Mount – Front                                    |  |                |                          |   |         |   |      |    |      |    |       |    |       |     |         |
| IP20, NEMA/UL Open Type                                 | 0...50 °C (32...122 °F) Frame 2...5, All Ratings   |                |                          |   |         |   |      |    |      |    |       |    |       |     |         |
| IP00, NEMA/UL Open Type                                 | 0...50 °C (32...122 °F) Frame 6...7, 12...456 A Ratings  |                |                          |   |         |   |      |    |      |    |       |    |       |     |         |
|   | 0...40 °C (32...104 °F) Frame 7, 477 A Rating  |                |                          |   |         |   |      |    |      |    |       |    |       |     |         |
| Back/Heat Sink  |  |                |                          |   |         |   |      |    |      |    |       |    |       |     |         |
| IP66, NEMA/UL Type 4X                                   | 0...40 °C (32...104 °F) Frame 2...7, All Ratings   |                |                          |   |         |   |      |    |      |    |       |    |       |     |         |
| Stand-alone/Wall Mount – IP54, NEMA/UL Type 12          | 0...40 °C (32...104 °F) Frame 2...7, All Ratings   |                |                          |   |         |   |      |    |      |    |       |    |       |     |         |
| Storage Temperature (all const.)                        | -40...70 °C (-40...158 °F)   |                |                          |   |         |   |      |    |      |    |       |    |       |     |         |
| Atmosphere  | <p><b>Important:</b> Drive <b>must not</b> be installed in an area where the ambient atmosphere contains volatile or corrosive gas, vapors, or dust. If the drive is not going to be installed for a period of time, it must be stored in an area where it will not be exposed to a corrosive atmosphere.</p> <p><b>Important:</b> Drives used with the safety function shall be protected against contaminants to an IP54 level. This can be accomplished by using IP54 rated enclosure or providing a dust free environment.</p> |                |                          |   |         |   |      |    |      |    |       |    |       |     |         |
| UV Radiation  | The HIM and IP54, NEMA/UL Type 12 drive plastics are not UV rated.   |                |                          |   |         |   |      |    |      |    |       |    |       |     |         |
| Relative Humidity                                       | 5...95% non-condensing   |                |                          |   |         |   |      |    |      |    |       |    |       |     |         |
| Shock - Operating                                       | <p>Frame 1...6: 15 g peak for 11 ms duration (±1.0 ms)</p> <p>Frame 7: 10 g peak for 11 ms duration (±1.0 ms)</p> <p>Frame 8...10: Power Core - 10 g peak for 11 ms duration (±1.0 ms) in Cabinet w/Option Bay - 5 g peak for 11 ms duration (±1.0 ms)</p>   |                |                          |   |         |   |      |    |      |    |       |    |       |     |         |
| Shock - Packaged for Shipment                           | <p>Frame 1...2: 381 mm (15 in.) drop height</p> <p>Frame 3...4: 330 mm (13 in.) drop height</p> <p>Frame 5: 305 mm (12 in.) drop height</p> <p>Frame 6...10: Meets International Safe Transit Association (ISTA) test procedure 2B</p>   |                |                          |   |         |   |      |    |      |    |       |    |       |     |         |
| Vibration - Operating                                   | <p>Frame 1...2: 1.000 mm (0.040 in.) displacement, 2 g peak</p> <p>Frame 3...5: 1.000 mm (0.040 in.) displacement, 1.5 g peak</p> <p>Frame 6...7: 1.000 mm (0.040 in.) displacement, 1 g peak</p> <p>Frame 8...10: Power Core, Drive in Cabinet w/Option Bay - 1.000 mm (0.040 in.) displacement, 1 g peak</p>   |                |                          |   |         |   |      |    |      |    |       |    |       |     |         |
| Vibration - Packaged for Shipment Sinusoidal Loose Load | <p>Frame 1...5: 20.0 mm (0.8 in.) peak to peak, 2...5.186 Hz; 1.1 g peak from 5.186...20 Hz</p> <p>Frame 6...10: Meets ISTA 2B packaging standards</p>   |                |                          |   |         |   |      |    |      |    |       |    |       |     |         |
| Random Secured  | <p>Frame 1...5:</p> <table border="1"> <thead> <tr> <th>Frequency (Hz)</th> <th>PSD (g<sup>2</sup>/Hz)</th> </tr> </thead> <tbody> <tr> <td>1</td> <td>0.00005</td> </tr> <tr> <td>4</td> <td>0.01</td> </tr> <tr> <td>16</td> <td>0.01</td> </tr> <tr> <td>40</td> <td>0.001</td> </tr> <tr> <td>80</td> <td>0.001</td> </tr> <tr> <td>200</td> <td>0.00001</td> </tr> </tbody> </table> <p>Frame 6...10: Meets International Safe Transit Association (ISTA) test procedure 2B</p>   | Frequency (Hz) | PSD (g <sup>2</sup> /Hz) | 1 | 0.00005 | 4 | 0.01 | 16 | 0.01 | 40 | 0.001 | 80 | 0.001 | 200 | 0.00001 |
| Frequency (Hz)  | PSD (g <sup>2</sup> /Hz)   |                |                          |   |         |   |      |    |      |    |       |    |       |     |         |
| 1   | 0.00005  |                |                          |   |         |   |      |    |      |    |       |    |       |     |         |
| 4   | 0.01   |                |                          |   |         |   |      |    |      |    |       |    |       |     |         |
| 16  | 0.01   |                |                          |   |         |   |      |    |      |    |       |    |       |     |         |
| 40  | 0.001  |                |                          |   |         |   |      |    |      |    |       |    |       |     |         |
| 80  | 0.001  |                |                          |   |         |   |      |    |      |    |       |    |       |     |         |
| 200   | 0.00001  |                |                          |   |         |   |      |    |      |    |       |    |       |     |         |

(1) Maximum surrounding air temperature of 50 °C (122 °F) with derating. See Derating Guidelines in the PowerFlex 750-Series AC Drives Technical Data, publication [750-TD001](#).

## Certifications

See the Product Certification link at [www.rockwellautomation.com/products/certification/](http://www.rockwellautomation.com/products/certification/) for Declarations of Conformity, Certificates, and other certifications details.

| Certification <sup>(1)</sup> | Value   |
|------------------------------|---|
| c-UL-us <sup>(2)</sup>       | UL Listed, certified for US and Canada.   |
| CE                           | European Union 2004/108/EC and 2014/30/EU EMC Directive, compliant with:<br>EN 61800-3; PowerFlex 750-Series AC Drive, Emissions and Immunity<br>EN 62061; Safety Function, Immunity<br>European Union 2006/42/EC Machinery Directive:<br>EN ISO 13849-1; Safety Function<br>EN ISO 13849-2; Safety Function<br>EN 60204-1; Safety Function<br>EN 62061; Safety Function<br>EN 61800-5-2; Safety Function |
| C-Tick                       | Australian Radiocommunications Act, compliant with:<br>EN 61800-3; categories C2 and C3   |
| TÜV                          | Certified by TÜV for Functional Safety:<br>up to SIL CL3, according to EN 61800-5-2, IEC 61508, and EN 62061;<br>up to Performance Level PL e and Category 4, according to EN ISO 13849-1;<br>when used as described in this PowerFlex 750-Series Safe Torque Off User Manual, publication 750-UM002.   |

(1) When product is marked, refer to [www.rockwellautomation.com/products/certification/](http://www.rockwellautomation.com/products/certification/) for Declarations of Conformity Certificates.

(2) Underwriters Laboratories Inc. has not evaluated the safe-off, safe torque-off, or safe speed-monitoring options for functional safety.

## CE Conformity

CE Declarations of Conformity are available online at:  
[www.rockwellautomation.com/products/certification/](http://www.rockwellautomation.com/products/certification/)

The 20-750-S Safe Torque Off module is in conformity with the essential requirements of the 2006/42/EC Machinery Directive and the 2004/108/EC EMC Directive when installed and maintained in accordance with the instructions contained in this document. The following standards have been applied to demonstrate conformity:

### Machinery Directive (2006/42/EC)

- EN ISO 13849-1:2008 Safety of machinery - Safety related parts of control systems - Part 1: General principles for design
- EN 60204-1:2006 + A1:2009 Safety of machinery - Electrical equipment of machines - Part 1: General requirements
- EN 62061:2005 + A1:2013 Safety of machinery - Functional safety of safety-related electrical, electronic and programmable electronic control systems
- EN 61800-5-2:2007 Adjustable speed electrical power drive systems - Part 5-2: Safety requirement - Functional
- IEC 61508 Part 1...7:2010 Functional safety of electrical/electronic/programmable electronic safety-related systems

### **EMC Directive (2004/108/EC and 2014/30/EU)**

- EN 61800-3:2004 + A1:2012 - Adjustable speed electric power drive systems - Part 3: EMC requirements and specific test methods



## Rockwell Automation Support

Rockwell Automation provides technical information on the Web to assist you in using its products.

At <http://www.rockwellautomation.com/support> you can find technical and application notes, sample code, and links to software service packs. You can also visit our Support Center at <https://rockwellautomation.custhelp.com/> for software updates, support chats and forums, technical information, FAQs, and to sign up for product notification updates.

In addition, we offer multiple support programs for installation, configuration, and troubleshooting. For more information, contact your local distributor or Rockwell Automation representative, or visit <http://www.rockwellautomation.com/services/online-phone>.

## Installation Assistance

If you experience a problem within the first 24 hours of installation, review the information that is contained in this manual. You can contact Customer Support for initial help in getting your product up and running.

|                                 |  |
|---------------------------------|--|
| United States or Canada         | 1.440.646.3434   |
| Outside United States or Canada | Use the <a href="#">Worldwide Locator</a> at <a href="http://www.rockwellautomation.com/rockwellautomation/support/overview.page">http://www.rockwellautomation.com/rockwellautomation/support/overview.page</a> , or contact your local Rockwell Automation representative. |

## New Product Satisfaction Return

Rockwell Automation tests all of its products to help ensure that they are fully operational when shipped from the manufacturing facility. However, if your product is not functioning and needs to be returned, follow these procedures.

|                       |   |
|-----------------------|---|
| United States         | Contact your distributor. You must provide a Customer Support case number (call the phone number above to obtain one) to your distributor to complete the return process. |
| Outside United States | Please contact your local Rockwell Automation representative for the return procedure.  |

## Documentation Feedback

Your comments will help us serve your documentation needs better. If you have any suggestions on how to improve this document, complete this form, publication [RA-DU002](#), available at <http://www.rockwellautomation.com/literature/>.

Rockwell Automation maintains current product environmental information on its website at <http://www.rockwellautomation.com/rockwellautomation/about-us/sustainability-ethics/product-environmental-compliance.page>.

Rockwell Otomasyon Ticaret A.Ş., Kar Plaza İş Merkezi E Blok Kat:6 34752 İçerenköy, İstanbul, Tel: +90 (216) 56984000

[www.rockwellautomation.com](http://www.rockwellautomation.com)

### Power, Control and Information Solutions Headquarters

Americas: Rockwell Automation, 1201 South Second Street, Milwaukee, WI 53204-2496 USA, Tel: (1) 414.382.2000, Fax: (1) 414.382.4444  
Europe/Middle East/Africa: Rockwell Automation NV, Pegasus Park, De Kleeflaan 12a, 1431 Drogen, Belgium, Tel: (32) 2 663 0600, Fax: (32) 2 663 0640  
Asia Pacific: Rockwell Automation, Level 14, Core F, Cyberport 3, 100 Cyberport Road, Hong Kong, Tel: (852) 2887 4788, Fax: (852) 2508 1846