



# VersaView 6300B Book Mount Box PCs and 6300T Book Mount Box Thin Clients

Bulletin Numbers 6300B-BMAx, 6300B-BMBx, and 6300T-BAx1



***Allen-Bradley***

by ROCKWELL AUTOMATION

User Manual

Original Instructions

## Important User Information

Read this document and the documents listed in the additional resources section about installation, configuration, and operation of this equipment before you install, configure, operate, or maintain this product. Users are required to familiarize themselves with installation and wiring instructions in addition to requirements of all applicable codes, laws, and standards.

Activities including installation, adjustments, putting into service, use, assembly, disassembly, and maintenance are required to be carried out by suitably trained personnel in accordance with applicable code of practice.

If this equipment is used in a manner not specified by the manufacturer, the protection provided by the equipment may be impaired.

In no event will Rockwell Automation, Inc. be responsible or liable for indirect or consequential damages resulting from the use or application of this equipment.

The examples and diagrams in this manual are included solely for illustrative purposes. Because of the many variables and requirements associated with any particular installation, Rockwell Automation, Inc. cannot assume responsibility or liability for actual use based on the examples and diagrams.

No patent liability is assumed by Rockwell Automation, Inc. with respect to use of information, circuits, equipment, or software described in this manual.

Reproduction of the contents of this manual, in whole or in part, without written permission of Rockwell Automation, Inc., is prohibited.

Throughout this manual, when necessary, we use notes to make you aware of safety considerations.



**WARNING:** Identifies information about practices or circumstances that can cause an explosion in a hazardous environment, which may lead to personal injury or death, property damage, or economic loss.

---



**ATTENTION:** Identifies information about practices or circumstances that can lead to personal injury or death, property damage, or economic loss. Attentions help you identify a hazard, avoid a hazard, and recognize the consequence.

---

**IMPORTANT** Identifies information that is critical for successful application and understanding of the product.

---

Labels may also be on or inside the equipment to provide specific precautions.



**SHOCK HAZARD:** Labels may be on or inside the equipment, for example, a drive or motor, to alert people that dangerous voltage may be present.

---



**BURN HAZARD:** Labels may be on or inside the equipment, for example, a drive or motor, to alert people that surfaces may reach dangerous temperatures.

---



**ARC FLASH HAZARD:** Labels may be on or inside the equipment, for example, a motor control center, to alert people to potential Arc Flash. Arc Flash will cause severe injury or death. Wear proper Personal Protective Equipment (PPE). Follow ALL Regulatory requirements for safe work practices and for Personal Protective Equipment (PPE).

---

## Safety Guidelines

The VersaView® 6300B book mount box PCs and 6300T book mount box thin clients in this publication must be operated only by qualified personnel. Quality personnel are those who, based on their training and experience, are able to identify risks and potential hazards while working with these computers.

The VersaView 6300B book mount box PCs and 6300T book mount box thin clients are only for indoor use. The computers can be damaged if operated outdoors.

The VersaView 6300B book mount box PCs and 6300T book mount box thin clients are open equipment, which means the following:

- This equipment can only be integrated in housings or cabinets where the computer is operated from the front panel.
- The housing or cabinet in which the computer is mounted can only be accessed with a key or tool, and only by qualified personnel.
- Before a housing or cabinet can be opened, all power must first be disconnected.

## Proper Disposal of the Computer

You cannot dispose of computer equipment like other waste material. Most computers and monitors contain heavy metals that can contaminate the earth. Therefore, check with local health and sanitation agencies for ways to dispose of monitor equipment safely.

### Battery Removal



This computer contains a sealed lithium battery that could need replacement during the life of the computer. At the end of its life, collect the battery that is contained in this computer separately from any unsorted municipal waste.

### Waste Electrical and Electronic Equipment (WEEE)



At the end of its life, collect this equipment separately from any unsorted municipal waste.

# Notes:

	Safety Guidelines . . . . .	3
	Proper Disposal of the Computer . . . . .	3
	<b>Preface</b>	
	Catalog Numbers . . . . .	7
	Summary of Changes . . . . .	7
	Additional Resources . . . . .	8
	<b>Chapter 1</b>	
<b>About the Box PC and Box Thin Client</b>	Computer Dimensions . . . . .	10
	Computer and Thin Client Connections . . . . .	11
	<b>Chapter 2</b>	
<b>Install the Box PC or Box Thin Client</b>	Unpack the Computer . . . . .	13
	Prepare for Installation . . . . .	13
	Environment and Enclosure Information . . . . .	13
	UL/cUL Mark Compliance . . . . .	14
	European Union Directive Compliance . . . . .	14
	Installation Guidelines . . . . .	14
	Mounting Requirements . . . . .	15
	Required Tools and Hardware for Installation . . . . .	15
	Install the Box PC or Box Thin Client . . . . .	15
	Connect Peripheral Cables . . . . .	15
	Grounding and Bonding . . . . .	15
	DC Power Supply Guidelines . . . . .	16
	Install the Ground Wire . . . . .	16
	Connect DC Power . . . . .	16
	Install the Factory-supplied DC Power Connector Assembly . . . . .	17
	<b>Chapter 3</b>	
<b>Operate the Box PC or Thin Client</b>	Operating Guidelines . . . . .	19
	Start the Box PC or Box Thin Client . . . . .	19
	Light-emitting Diode and Button Descriptions . . . . .	19
	Restart or Reset the VersaView 6300B Box PC . . . . .	21
	Restart the VersaView 6300B Box PC . . . . .	21
	Reset the VersaView 6300B Box PC . . . . .	21
	Shut Down the VersaView 6300B Box PC . . . . .	22

---

**Configure, Restore, and Update  
System Settings**

**Chapter 4**

Access the Set-up Utility ..... 23  
Common Set-up Modifications ..... 24  
Initial Steps to Back Up or Restore a Windows OS Image ..... 24  
    Download the Accessory Files ..... 24  
    Create a Bootable USB Drive ..... 25  
Back Up the OS Image ..... 25  
Restore the OS Image ..... 27  
Update to a New UEFI ..... 28  
    Verify or Create a FAT32-formatted USB Drive ..... 28  
    Download the UEFI Update Files ..... 29  
Restore Factory Defaults Through a DIP Switch ..... 33  
    For VersaView 6300B-BMAx Box PCs and  
    6300T-BAx1 Thin Clients ..... 33  
    For VersaView 6300B-BMBx Box PCs ..... 34

**Clean the Box PC and Box Thin  
Client**

**Chapter 5**

Clean the Vent Holes ..... 37

**Troubleshoot the System**

**Chapter 6**

Thermal Alarms ..... 39  
Troubleshooting ..... 39  
Load the System Defaults ..... 40  
Ship or Transport the Computer ..... 40  
Dispose of the Computer ..... 40

**Replace Components**

**Chapter 7**

Replacement Parts ..... 41  
Voltage Precautions ..... 41  
Electrostatic Discharge Precautions ..... 41  
Pre-configuration ..... 42  
Post-configuration ..... 42  
Remove the Cover ..... 43  
    For VersaView 6300B-BABx Box PCs and  
    6300T-BAx1 Thin Clients ..... 43  
    For VersaView 6300B-BMBx Box PCs ..... 44  
Replace the Battery ..... 44  
    For VersaView 6300B-BMBx Box PCs ..... 45  
Reinstall the Cover ..... 47  
    For VersaView 6300B-BABx Box PCs and  
    6300T-BAx1 Thin Clients ..... 47  
    For VersaView 6300B-BMBx Box PCs ..... 48

This manual is a user guide for VersaView® 6300B book mount box PCs and 6300T book mount box thin clients. It provides procedures to the following:

- Install the computer.
- Make computer connections.
- Operate the computer.
- Troubleshoot the computer.

A general knowledge of automation technology is needed to understand and follow the instructions in this publication.

Knowledge of personal computers and Microsoft Windows® operating systems<sup>(1)</sup> are required to understand and follow the instructions in this publication.

## Catalog Numbers

This publication is applicable to these VersaView box PCs and box thin clients. For your catalog number, see the product label on the side of your computer.

VersaView book mount box PCs with no front panel doors	6300B-BMAx
VersaView book mount box PCs with one or two front panel doors	6300B-BMBx
VersaView book mount box thin clients with no front panel doors	6300T-BAx1

## Summary of Changes

This publication contains the following new or updated information. This list includes only substantive updates and is not intended to reflect all changes.

Topic	Page
Added third paragraph and photograph of Cat. No. 6300B-BMBx.	9
Added Cat. Nos. 6300B-BMBx dimensions and acceptable mounting positions to Figure 1.	10
Added Figure 3, VersaView 6300B-BMBx Peripheral Connections.	11
Added footnote to table in Parts List section.	13
Added temperature ranges for Cat. Nos. 6300B-BMBx in the second bullet point and the footnote.	14
Added the third bullet point about active fan cooling for expansion cards.	14
Revised graphic and added table for the inrush current bullet point.	16
Added both Important tables and Table 1 to Install the Factory-supplied DC Power Connector Assembly section.	17
Added Table 3, LEDs and Buttons on Cat. Nos. 6300B-BMBx.	21
Added Initial Steps to Back Up or Restore a Windows OS Image section.	24
Added Back Up the OS Image section.	25
Added Restore the OS Image section.	27
Expanded Update to a New UEFI section.	28
Added Restore Factory Defaults Through a DIP Switch section.	33
Added Dispose of the Computer section.	40
Added the subsection, For VersaView 6300B-BMBx Box PCs, in Remove the Cover section.	44
Added the subsection, For VersaView 6300B-BMBx Box PCs, in Remove the Battery section.	45
Added the subsection, For VersaView 6300B-BMBx Box PCs, in Reinstall the Cover section.	48

(1) VersaView 6300T thin clients do not operate with Microsoft Windows operating systems.

## Additional Resources

These documents contain additional information about related products from Rockwell Automation.

Resource	Description
VersaView 6300B Box PCs and 6300T Box Thin Client Installation Instructions, publication <a href="#">6300B-IN001</a>	Provides basic installation guidelines and instructions for VersaView 6300B box PCs and 6300T box thin clients.
VersaView 6300 Industrial Computer and Monitor Specifications Technical Data, publication <a href="#">IC-TD003</a>	Provides technical specifications about all VersaView 6300 industrial PCs, thin clients, and monitors.
ThinManager® 11.2 User Guide, publication <a href="#">TM-UM001</a>	Provides instructions to define sources, deploy content, configure devices, and user access between a server and thin clients.
Industrial Automation Wiring and Grounding Guidelines, publication <a href="#">I770-4.1</a>	Provides general guidelines for installing a Rockwell Automation industrial system.
Product Certifications website, <a href="http://rok.auto/certifications">rok.auto/certifications</a>	Provides declarations of conformity, certificates, and other certification details.

You can view or download publications at [rok.auto/literature](http://rok.auto/literature).



## About the Box PC and Box Thin Client

The Allen-Bradley® VersaView® 6300B book mount box PCs and 6300T book mount box thin clients have a fanless design, which is optimal for applications that require low maintenance. The most compact PCs in this family (Cat. Nos. 6300B-BMAx) and box thin clients (Cat. Nos. 6300T-BAX1) feature Intel (Apollo Lake) Atom processors. Slightly larger box PC models (Cat. Nos. 6300B-BMBx) feature Intel Core i-class processors for mid-size applications.



Cat. Nos. 6300B-BMAx and 6300T-BAX1

The following features are available for the VersaView 6300B box PCs (Cat. Nos. 6300B-BMAx) and 6300T box thin clients (Cat. Nos. 6300T-BAX1):

- For the 6300B box PCs, available with Microsoft Windows® 10 IoT Enterprise 2019 LTSC<sup>(1)</sup>
- For the 6300T box thin clients, they are ThinManager® ready
- For the 6300B box PCs, SSD storage (no drives in 6300T box thin clients)
- One DisplayPort video output supports up to 4K high resolution
- 2 x Ethernet and 2 x USB 3.0 (Type A) ports
- Fanless design for 24V DC SELV input power



Cat. No. 6300B-BMBx

The following features are available for the VersaView 6300B box PCs (Cat. Nos. 6300B-BMBx):

- Available with Microsoft Windows 10 IoT Enterprise 2019 LTSC<sup>(2)</sup>
- 4 x Ethernet, 3 x USB 3.0 (Type A), 2 x USB 2.0 (Type A), 1 x RS-232 (DB9M), and 1 x DVI-D ports
- 1 x CFast card slot
- Up to 2 PCIe x4 expansion slots
- Extractable SSD storage<sup>(2)</sup>
- Fanless design for 24V DC SELV input power

(1) All 6300B book mount box PCs are ThinManager compatible.

(2) One model is available with no storage drive and no Windows operating system.

# Computer Dimensions

The following figure shows the dimensions of the VersaView 6300B box PCs and 6300T thin clients.

**Figure 1 - VersaView 6300B and 6300T Dimensions**

All dimensions are in mm (in.). Both illustrations are not-to-scale.

**6300B-BMAx Box PCs and 6300T-BAx1 Thin Clients**

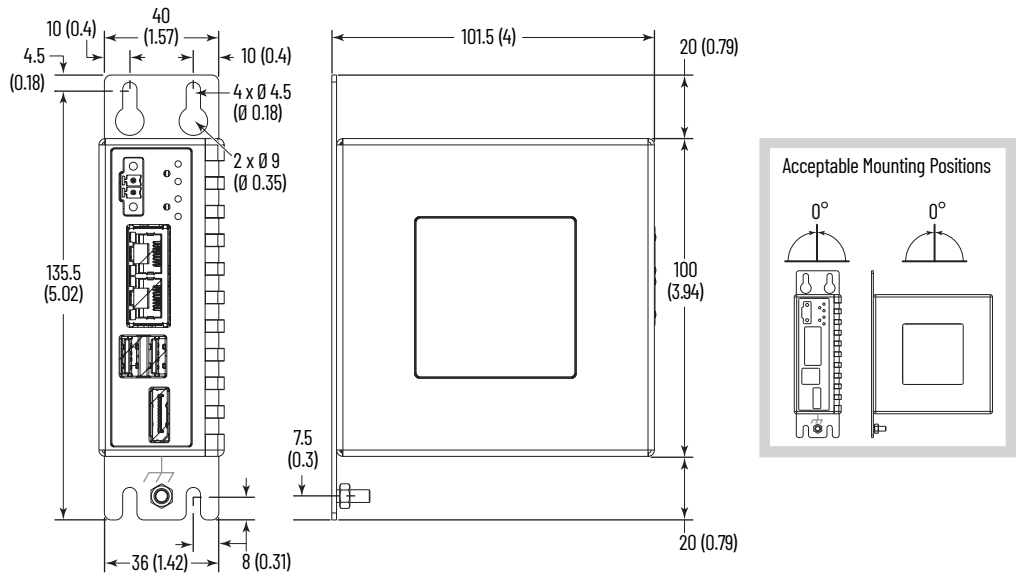

**6300B-BMBx Box PCs (shown with both front doors closed)**

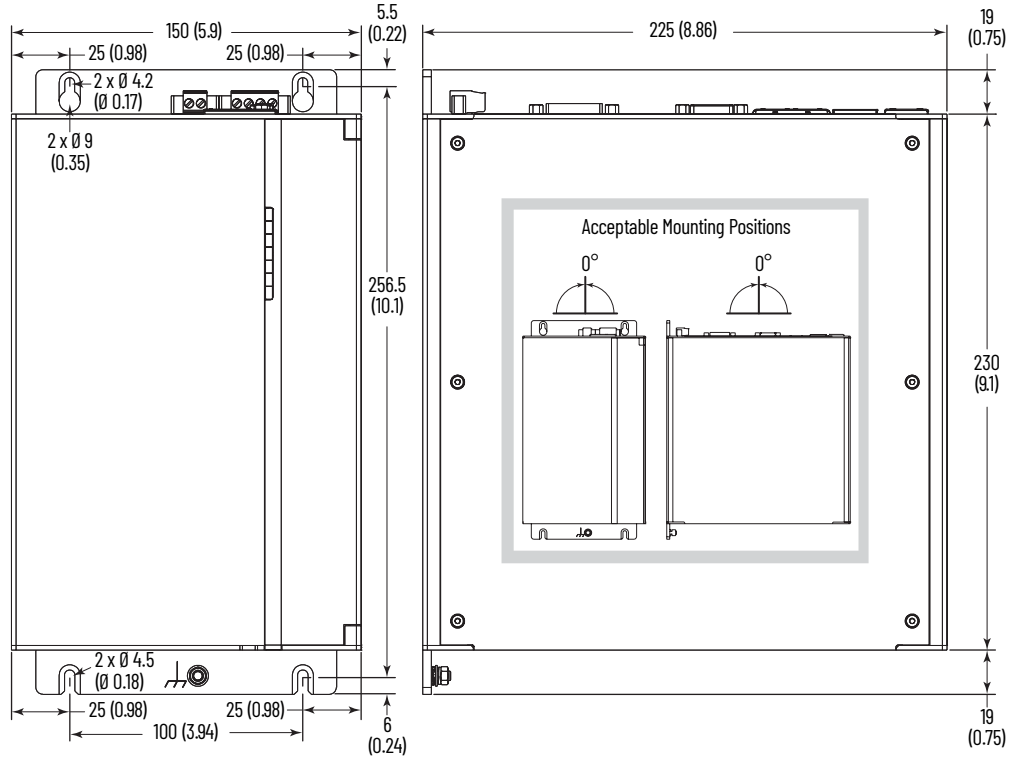

## Computer and Thin Client Connections

The next two figures show the connections of VersaView 6300B box PCs and 6300T thin clients.

**Figure 2 - VersaView 6300B-BABx and 6300T-BAx1 Connections**

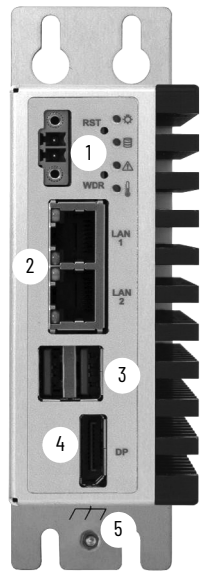

No.	Description
1	24V DC power input connection
2	2 x Ethernet LAN port
3	2 x USB 3.0 (Type A) port
4	DisplayPort video output
5	Ground (earth) screw

**Figure 3 - VersaView 6300B-BMBx Connections**

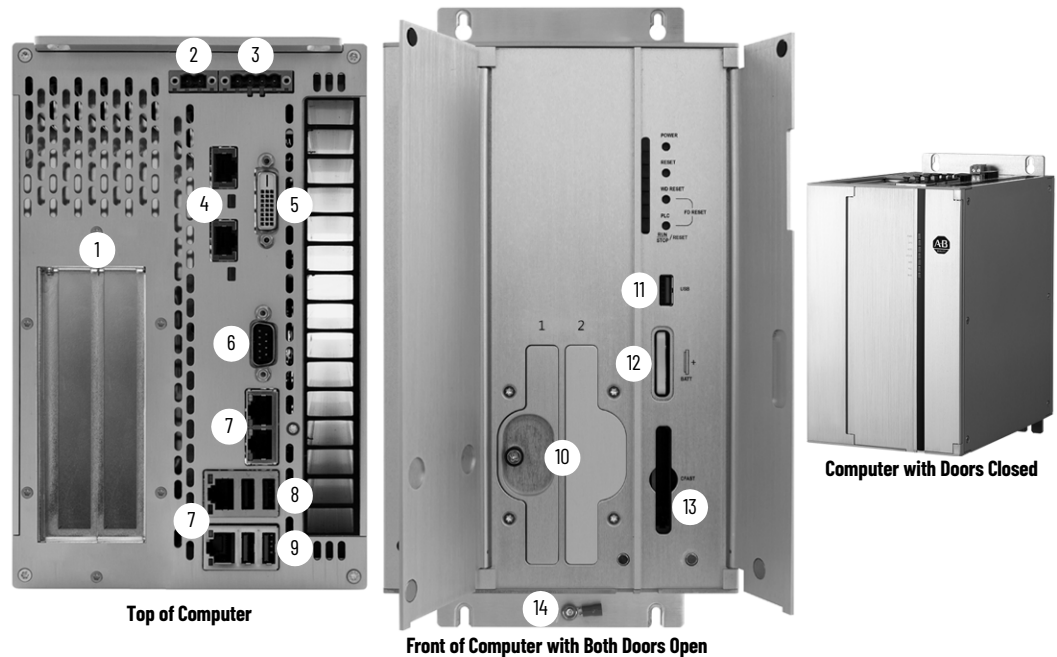

No.	Description
1	2 x PCIe x4 (Gen 3) expansion slot
2	24V DC power input connection
3	UPS connection <sup>(1)</sup>
4	2 x RVL Out <sup>(2)</sup>
5	DVI-D port

No.	Description
6	Serial port, RS-232 (DB9M)
7	4 x Ethernet LAN port
8	2 x USB 2.0 (Type A) port
9	2 x USB 3.0 (Type A) port
10	Up to 2 SSD SATA III extractable drawers

No.	Description
11	USB 3.0 (Type A) port
12	Battery slot
13	CFAST SATA III card slot
14	Ground (earth) screw

(1) Uninterruptible Power Source, which is a future option.  
 (2) Remote Video Link, which is a future option.

**Notes:**

## Install the Box PC or Box Thin Client

Follow these guidelines and procedures to help you plan your installation, and mount and power up the box PC or box thin client.

### Unpack the Computer

Before you unpack the computer, inspect the shipping carton for damage. If damage is visible, immediately contact the shipper and request assistance. Otherwise, proceed with unpacking.

Keep the original packing material in case you must return the computer for repair or transport it to another location.

The box PC or box thin client ship with the following items.

#### Parts List

Item	Description
Hardware	<ul style="list-style-type: none"> <li>Factory installed mounting bracket<sup>(1)</sup></li> <li>DC power connector assembly kit</li> </ul>
Document	VersaView® 6300B Book Mount Box PC and 6300T Book Mount Box Thin Clients Installation Instructions, publication <a href="#">6300B-IN001</a>

(1) Cat. Nos. 6300B-BMAx box PCs and 6300T-BAx1 thin clients have mounting brackets that can be removed and replaced with other brackets.

### Prepare for Installation

Read and follow these precautions for you install the box PC or box thin client.

#### Environment and Enclosure Information



**ATTENTION:** This equipment is intended for use in a Pollution Degree 2 industrial environment, in overvoltage Category II applications (as defined in IEC 60664-1), at altitudes up to 2000 m (6561 ft) without derating.

This equipment is considered Group 1, Class A industrial equipment according to IEC/EN 61326-1. Without appropriate precautions, there can be potential difficulties with electromagnetic compatibility in other environments due to conducted as well as radiated disturbance.

This equipment is considered open equipment, which means it must be mounted in an enclosure where the equipment can be operated from the front panel.

The enclosure in which this equipment is installed must be accessed only with a key or tool, and only by trained and authorized personnel.

In addition to this publication, see the following:

- Industrial Automation Wiring and Grounding Guidelines, publication [1770-4.1](#), for more installation requirements
- UL 50, CSA C22.2 No. 94.1, and IEC 60529, as applicable, for explanations of the degrees of protection provided by enclosures

## UL/cUL Mark Compliance

Equipment with the UL/cUL mark complies with the requirements of UL 61010-1, UL 61010-2-201, CSA C22.2 No. 61010-1, and CSA C22.2 No. 61010-2-201. A copy of the certificate of compliance is available at [rok.auto/certifications](http://rok.auto/certifications).

## European Union Directive Compliance

This computer meets the European Union Directive requirements when installed within the European Union or EEA regions and have the CE marking. A copy of the declaration of the conformity is available at [rok.auto/certifications](http://rok.auto/certifications).



**ATTENTION:** This equipment is intended to operate in an industrial or control room environment, which uses some form of power isolation from the public low-voltage mains. Obtain permission from the local power authority before you connect any computer configuration that draws more than 75 W of AC power directly from the public mains.

All I/O cables must be used only indoors.

Connect peripheral cables to the appropriate I/O ports on the computer. To comply with EN 61326-1, see [Connect Peripheral Cables on page 15](#) for the required cable types.

## Installation Guidelines

Follow these guidelines to make sure that your computer provides service with excellent reliability.

- When choosing the installation site, consider the following:
  - The site must have sufficient power
  - The site must be indoors
  - The site must not expose the computer to direct sunlight
- The computers can operate in a surrounding air temperature as follows:
  - 0...55 °C (32...131 °F) with the Intel Atom x5 processor
  - 0...50 °C (32...122 °F) with the Intel Atom x7 processor, and Intel Core i3 and i5 processors
  - 0...45 °C (32...113 °F) with Intel Core i7 processors<sup>(1)</sup>

The surrounding air temperature must not exceed the maximum temperature for your computer, especially when the computer is mounted in an enclosure.

- Active fan cooling is needed when you use expansion cards in Cat. Nos. 6300B-BMBx box PCs with total power consumption between 10...20 W, with 20 W as the maximum.
- The computers can be stored in a surrounding air temperature range of -10...+60 °C (14...140 °F).
- The humidity of the ambient air must not exceed 80% noncondensing.

(1) Temperature range without forced ventilation. With forced ventilation, 0...50 °C (0...122 °F).

## Mounting Requirements

Follow these requirements to mount the box PC or thin client.

- Choose a suitable mounting height.
- Only mount the computer in a vertical (upright) position where the ground screw is at the bottom, as shown in [Figure 1 on page 10](#).
- Mount the computer so there is at least 20 mm (0.8 in.) of clearance on each side for the circulation necessary for cooling.

## Required Tools and Hardware for Installation

The following tools and hardware are needed for book mount installations.

- Drill and 4 mm drill bit
- #2 Phillips screwdriver
- Four M4x20 stainless steel screws (customer supplied)
- Safety glasses

## Install the Box PC or Box Thin Client

VersaView 6300B box PCs and VersaView 6300T box thin clients are shipped with book mount brackets that are factory-installed.

To mount the computer, perform the following steps.

1. Use the dimensions in [Figure 1 on page 10](#) to locate and drill holes for the four M4x20 stainless steel screws.
2. Install the four customer-supplied screws but leave enough space to hang the brackets.
3. Align the keyhole slots on the top bracket with the top two screws.
4. Align the slots on the bottom bracket with the bottom two screws.
5. Slide the computer downward until all four screws are at the top of each bracket slot.
6. Tighten the four screws.

## Connect Peripheral Cables

Connect peripheral cables to the appropriate I/O ports on the computer. For available connections, see [Figure 2](#) or [Figure 3](#) on [page 11](#).

To comply with EN 61326-1, use the following for cable types. All I/O cables must be used only indoors, and USB cables must be less than 3 m (9.84 ft) long.

Cable Type	Required Attribute	Cable Type	Required Attribute
LAN	Shielded	DisplayPort	Shielded
USB (2.0 and 3.0)		RVL <sup>(1)</sup>	
RS-232 DB9M		DC power	Unshielded
DVI-D		UPS connection <sup>(1)</sup>	

(1) A future option.

## Grounding and Bonding

Whenever two connected pieces of equipment are far apart, it is possible that their ground connections could be at a different potential level.

To overcome these possible spikes, the following bonding methods are recommended:

- Method 1: Connect the data cable shields to the equipotential bonding rail on both sides before you connect the cable to the interfaces.

- Method 2: Use an equipotential bonding cable (16 mm<sup>2</sup> or 6 AWG) to connect the grounds between this VersaView 6300B box PC or 6300T thin client and a connected monitor.

## DC Power Supply Guidelines

Follow these guidelines to select the DC power supply for the computer.

- The computer must be powered with a voltage of 24V DC (18...32V DC input voltage range).
- The nominal output power must be 25% larger than the drained power.
- The output voltage rise time has to be less than 100 ms.
- Consider the working temperature and the thermal derating of the power supply.
- The inrush current can be represented by the following figure:

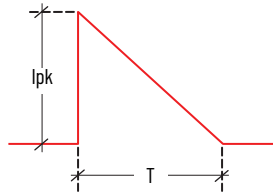

Symbol	Definition	6300B-BMAx, 6300T-BAx1	6300B-BMBx
Ipk	Peak current	10 A	<13 A
T	Pulse width time	400 μs	0.2 ms

## Install the Ground Wire

1. Turn off the main power switch or breaker.
2. Remove the supplied nut, eyelet terminal, and washers from the ground screw.
3. For earth ground, fasten a 2.5 mm<sup>2</sup> (14 AWG) or larger external wire to the eyelet terminal.

Use a ground wire with an insulation color that is approved by local inspection authority.

4. Install the ground wire to the ground screw in the following sequence.



Sequence No.	Description
1	Toothed washer
2	Eyelet terminal
3	Washer

Sequence No.	Description
4	Lock washer
5	Nut

5. Tighten the nut to the ground screw.

## Connect DC Power



**ATTENTION:** When you connect power to the thin client or computer for the first time, these actions occur:

- The default UEFI setting automatically starts the computer after it is plugged into a power source.
- For VersaView 6300B box PCs with a Microsoft Windows operating system (OS), you must read and accept an End User Setup procedure.

**Do not disconnect power from the system until after the Windows Setup procedure is completed. If power is disconnected during this procedure, it can result in a corrupted system image.**

If the system image is corrupted, then follow the steps to [Restore the OS Image on page 27](#).



Operate the box PC or box thin client in an industrial or control room environment, which uses some form of power isolation from the public, low-voltage mains.



**ATTENTION:** For VersaView 6300B book mount box PCs with a Windows OS, perform the following:

- Supply the computer with its own disconnect. Use an uninterruptible power source (UPS) to help protect against unexpected power failure or power surges.
- Always shut down the Windows OS before you disconnect power to the computer to minimize performance degradation and operating system failures.

If the system image is corrupted, then follow the steps to [Restore the OS Image on page 27](#).

All VersaView DC powered models require a safety extra low voltage (SELV)<sup>(1)</sup> power supply per UL. The power supply is internally protected against reverse polarity.

To minimize ground loop currents and noise, Allen-Bradley recommends that DC powered models use only one grounded connection. See [Install the Ground Wire on page 16](#) for the ground connection on these models.

Follow these steps to connect the computer to a DC power source.



You need the following tools for this installation:

- Adjustable torque screwdriver with M2 and M3 flat-blade screw bits
- Wire stripper, cutter, and crimper tool
- Cutting pliers

## Install the Factory-supplied DC Power Connector Assembly

This connector assembly provides strain relief for the DC power wires by reducing their movement. To assemble and attach the connector assembly, perform the following steps.

**IMPORTANT** DC power wires must be of stranded copper and sized according to [Table 1](#).

1. Remove the DC terminal block from the computer chassis.
2. Open the power connector assembly kit that ships with the computer (A on [page 18](#)).
3. Insert the cable tie through the slots of the appropriate connector half (B on [page 18](#)).
4. Strip the end of each DC power wire to the length in [Table 1](#).
5. Insert each stripped end into the DC terminal block as shown in [Table 1](#).



**IMPORTANT** The DC terminal block in the photos is only for illustrative purposes. Your DC terminal block can differ in size, shape, and color to what is shown in the photos.

(1) Where SELV is as defined in IEC 61010-2-201.

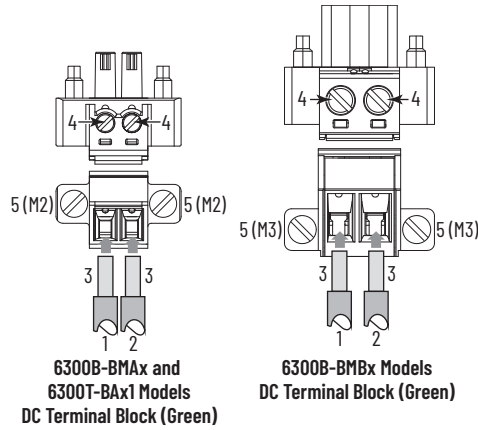
**Table 1 - DC Terminal Block Connection Specifications**



Item	Description	6300B-BMAx and 6300T-BAx1 Models	6300B-BMBx Models
1	DC+ (24V DC nominal) recommended power wire size	1.5 mm <sup>2</sup> (16 AWG)	2.5 mm <sup>2</sup> (14 AWG)
2	DC- (0V DC) recommended power wire size		
3	Stripped wire length	7 mm (0.275 in.)	
4	Torque range to secure DC power wires	0.22...0.25 N•m (0.16...0.18 ft•lb)	0.5...0.6 N•m (0.37...0.4 ft•lb)
5	Torque value to reinstall DC terminal block to computer	0.3 N•m (0.22 ft•lb)	

6. Tighten the screws on top of the terminal block to secure the DC power wires to the torque value in [Table 1](#).
7. Slide the connector half with the attached tie onto the end of the DC terminal block (C on [page 18](#)).
8. Tighten the cable tie so it is snug against the terminal wires.
9. Use cutting pliers to cut the excess part of the cable tie (D on [page 18](#)).
10. Install the white label supplied with the kit (E).
  -  The white label can be used for identification or other information.
11. Align and install the other connector clamp half to complete the assembly (F).
  -  When installed correctly, both tabs of the clamp half lock into place.
12. Reconnect the DC terminal block with the connector assembly to the computer chassis.
 

Torque the DC terminal block flange screws to the values in [Table 1 on page 18](#).
13. Turn on the main power switch or breaker.

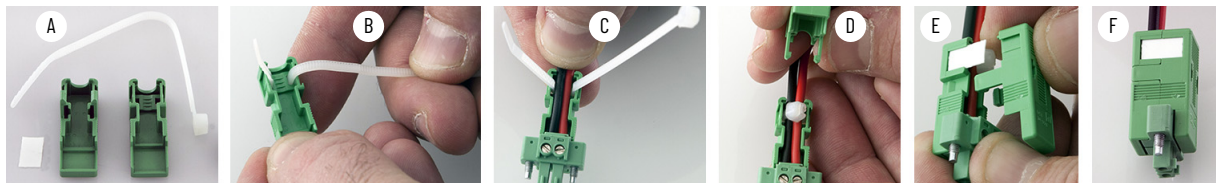

## Operate the Box PC or Thin Client

### Operating Guidelines

Follow these operating guidelines for your VersaView® 6300B box PC or 6300T thin client.

- When the box PC or box thin client is mounted in an enclosure, keep the enclosure door closed during operation so dust and other airborne contamination do not infiltrate the thin client or computer. Open the door only for routine maintenance.
- For box PCs with a Microsoft Windows® operating system (OS), always use the proper power down procedures as required, such as the Shut Down command in the Windows OS.
- After you shut down the box PC or box thin client, do not apply power again until shutdown is complete.

### Start the Box PC or Box Thin Client

Follow these steps to start your VersaView 6300B box PC or 6300T thin client.

---

#### IMPORTANT

The following steps apply to when the thin client or computer must be started manually, and DC power has been connected already.

See [Connect DC Power on page 16](#) for when power is applied to the box PC or box thin client for the first time.

---

1. Make sure all necessary peripheral devices are connected to the corresponding I/O ports on the box PC or box thin client.
2. Make sure any connected components with separate power supplies (such as an external display) are turned on first.
3. To power on the box PC or box thin client, press the system or power reset button on the front panel. For button locations, see [Table 2](#) or [Table 3 on page 20](#).

### Light-emitting Diode and Button Descriptions

After a VersaView 6300B box PC or 6300T thin client is powered on, various light-emitting diodes (LEDs) monitor its state. Use these LEDs to determine if they are lit and what color they emit.

There are also buttons on the computer to reset computer states that are monitored by the LEDs.

The following tables detail what LEDs and buttons are on each 6300B box PC and 6300T box thin client.

Table 2 - LEDs and Buttons on Front Panel of VersaView 6300B-BMAx Box PCs and VersaView 6300T-BAX1 Box Thin Clients

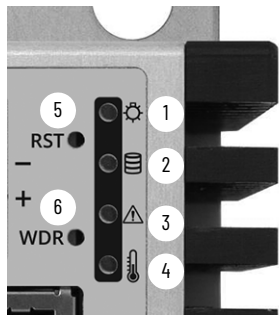

No.	Description	Color	Function
1	Standby/power on LED	No color	The computer is powered off.
		Green	The computer is powered on.
		Yellow	The computer is safe to power off; the operating system has been shut down successfully. <sup>(1)</sup>
		Flashing green	The computer is in a low-power state; the current session information is being stored in the RAM.
2	Mass storage LED	Yellow	When lit, access to a mass storage device (SSD, or CF) is happening through a SATA channel.
3	Watchdog error LED	Red	When lit, the watchdog timer has expired.
4	Thermal alarm/low battery LED	Flashing red	When flashing, a thermal sensor on the motherboard near the CPU has exceeded the thermal limit of 85 °C (185 °F).
5	System reset button	—	For the main reset of the system. Press this button once to restart the computer and reset the system state.
6	Watchdog reset button	—	Press this button once to reset the watchdog error LED.

(1) Microsoft Windows® operating systems are not installed on VersaView 6300T thin client models.

Table 3 - LEDs and Buttons on the Front Panel of VersaView 6300B-BMBx Box PCs<sup>(1)</sup>

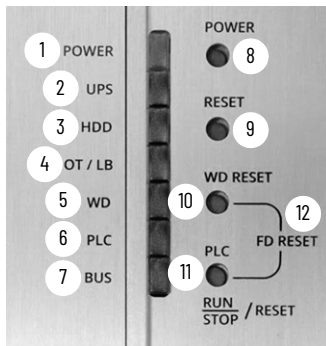

No.	Description	Color	Function
1	Power on LED	No color	The computer is powered off.
		Green	The computer is powered on.
		Yellow	The computer is safe to power off; the operating system has been shut down successfully.
2	UPS LED (optional item)	No color	No uninterruptible power supply (UPS) battery pack is installed.
		Green	The computer is powered by an external 24V DC source, and the UPS is not being used.
		Yellow	The UPS battery pack is disconnected.
		Flashing green	The computer is being powered by the UPS because the external 24V DC source is lost.
3	Mass storage LED	Yellow	When lit, access to a mass storage device (SSD or CFast) is happening through a SATA channel.
		Red	A thermal sensor on the motherboard near the CPU has exceeded the thermal limit of 85 °C (185 °F).
4	Thermal alarm/low battery LED	Flashing red	The real-time clock (RTC) battery is lower than 2.5V. Replace before the battery goes lower and risks loss of date and time.
		Red	The watchdog timer has expired.
5	Watchdog error LED	Red	The watchdog timer has expired.
6	PLC status LED <sup>(2)</sup>	—	
7	BUS status LED <sup>(2)</sup>	—	
8	Power on reset button	—	Turns the computer on or off.
9	System reset button	—	Forces an internal reset, as if power was lost temporarily and then returned. <b>IMPORTANT:</b> Use this button only if there are no better options, like keyboard or mouse commands. System reset can cause data loss and possible corruption to the operating system.
10	Watchdog reset button	—	Turns off the watchdog LED (item 5).
11	PLC run/stop/reset button <sup>(3)</sup>	—	
12	Factory default reset button <sup>(3)</sup>	—	

(1) You must open the front right door to access the buttons that are described in items 8...12.

(2) Not applicable.

(3) Not implemented.

**Table 4 - LAN LEDs on the Front Panel of VersaView 6300B-BMAx Box PCs and VersaView 6300T-BAx1 Box Thin Clients, and on the Top Panel of VersaView 6300B-BMBx Box PCs**

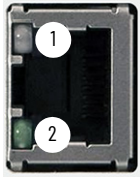

No.	Description	Color	Function
1	Data link	No color	No data link is present.
		Green	Data link is established.
		Flashing green	Data link is established and there is data transfer.
2	Data speed	No color	10 Mbps
		Green	100 Mbps
		Yellow	1000 Mbps (1 Gbps)

## Restart or Reset the VersaView 6300B Box PC

### IMPORTANT

The instructions in this section are only for VersaView 6300B book mount box PCs with Windows operating systems.

VersaView 6300T book mount box thin clients can be restarted or shut down through the ThinManager® software on the server. For more information, see the ThinManager 11.2 User Guide, publication [TM-UM001](#).

## Restart the VersaView 6300B Box PC

### IMPORTANT

A connected keyboard, mouse, and display are needed for some of the following steps.

Use either of the following methods to restart the box PC.

- From the Start menu, click or choose Restart.
- Press Ctrl+Alt+Delete, and then click or choose Restart.

During a restart, the box PC does the following:

- Clears the RAM.
- Starts the POST.
- Initializes peripheral devices.
- Loads the Windows OS.

Use a connected display to view the progress of the POST, initializing of any peripheral devices, and the startup dialogs for any installed Windows OS.

## Reset the VersaView 6300B Box PC

### IMPORTANT

Use this method only if there are no better options, like keyboard or mouse commands. System reset can cause data loss and possible corruption to the operating system.

Use this method when power has been interrupted temporarily, and the box PC is unresponsive when power returns.

If methods to restart the box PC are unsuccessful, then press the system reset button on the front panel of the box PC.

For the system reset button location, see [Table 2](#) and [Table 3](#) on [page 20](#).

## Shut Down the VersaView 6300B Box PC

---

**IMPORTANT** The instructions in this section are only for VersaView 6300B box PCs with Windows operating systems.

VersaView 6300T thin clients can be shut down through the ThinManager software on the server. For more information, see the ThinManager 11.2 User Guide, publication [TM-UM001](#).

---

**IMPORTANT** A connected keyboard, mouse, and display are needed for the following steps.

---

Use either of the following methods to shut down the box PC.

- From the Start menu, click or choose Shut Down.
- Press Ctrl+Alt+Delete, and then click or choose Shut Down.

## Configure, Restore, and Update System Settings

Each VersaView® 6300B box PC and 6300T thin client has a set-up utility, which is a hardware configuration program that is built into the universal extensible firmware interface (UEFI).

You can run the set-up utility to do the following:

- Change the system configuration.
- Set the time and date as part of a commissioning step.



A commissioning step is one of the following situations:

- When the VersaView 6300B box PC or 6300T thin client is powered up initially
- When the Windows OS image is restored (only on VersaView 6300B box PCs)
- When the UEFI is upgraded

Information is included in this chapter to restore and back up the Microsoft Windows® OS image, and to upgrade the UEFI.

- Redefine communication ports to help prevent any conflicts.
- Read the current amount of system memory.
- Change the boot drive order.
- Set or change the password or make other changes to the security settings.

### Access the Set-up Utility

Follow these steps to access the set-up utility in your box PC or box thin client.

---

**IMPORTANT** To perform these steps, an external display and keyboard must be connected to the computer.

---

1. Start or restart your computer.
2. During POST, press F2 to access the set-up utility.
3. The following screens are accessible through the set-up utility:
  - Main (default screen when you access the utility)
  - Advanced
  - Security
  - Boot



If you wish to change the boot order temporarily, press F10 during POST to access the boot menu directly.

- Exit
4. Use the following keys to navigate in the set-up utility (numeric keypad keys are in parentheses):
    - Up (8) and down (2) arrows to toggle between fields in the current menu
    - PgUp (9) and PgDn (3) to toggle between the previous or next page on scrollable menus

- Home (7) and End (1) to move to the top and bottom items in the current menu
- Within a field, F5 or minus (-) to select the next lower value, and F6 or plus (+) to select the next higher value
- Left (4) and right (6) arrows to select menus on the menu bar

## Common Set-up Modifications

With pre-arranged configurations, there is usually no need to change specific items. Some exceptions are as follows:

- Change the system date and time
  - Available on the Main menu
  - On box PCs with Microsoft Windows OS, you can also change these settings through the Control Panel > Date and Time
- View UEFI version and system memory
  - Under the System Information setting on the Main menu
  - On box PCs with Microsoft Windows OS, you can view these settings by Windows > System Information
- Modify the boot device order
  - Under the Boot menu; use to prioritize storage devices
- Modify network configuration
  - Under the Advanced menu; use when a LAN with a pre-boot execution environment (PXE) is needed
- Add passwords
  - Under the Security menu; use when system security is needed

## Initial Steps to Back Up or Restore a Windows OS Image



Before you can back up or restore the Microsoft Windows OS image on your computer, you must first download the accessory files (system image, and backup and restore files) and then create a bootable USB drive.

### Download the Accessory Files

To download the accessory files, perform the following steps.

#### IMPORTANT

To perform these steps, an external display and keyboard must be connected to the computer.

1. Access the Rockwell Automation® Product Compatibility and Download Center (PCDC) website at: <https://compatibility.rockwellautomation.com/Pages/home.aspx>.
2. On the home page, click Find Downloads.
3. On the Find Downloads page, use your computer model as the search criteria.
4. Follow the instructions on the PCDC site to find your accessory files.
  -  You must be registered with the Rockwell Automation PCDC website and accept a User Agreement before you can download files.
5. Select and download the accessory files to your computer desktop.
  -  Use the appropriately named batch (BAT) file to [Back Up the OS Image on page 25](#) or to [Restore the OS Image on page 27](#).

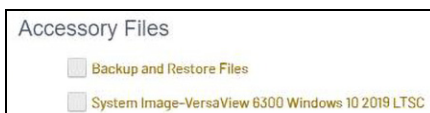



## Create a Bootable USB Drive

To create a bootable USB drive, you need the following:

- A display
- A keyboard
- A USB drive (16 GB minimum)
- A utility installed on your computer that can create a bootable USB drive



Rufus is a commonly used utility and the one used in the following examples. Rufus is free software that can be downloaded at <https://rufus.ie/>.

Other utilities can offer slightly different methods to create a bootable USB drive. In those cases, follow their instructions.

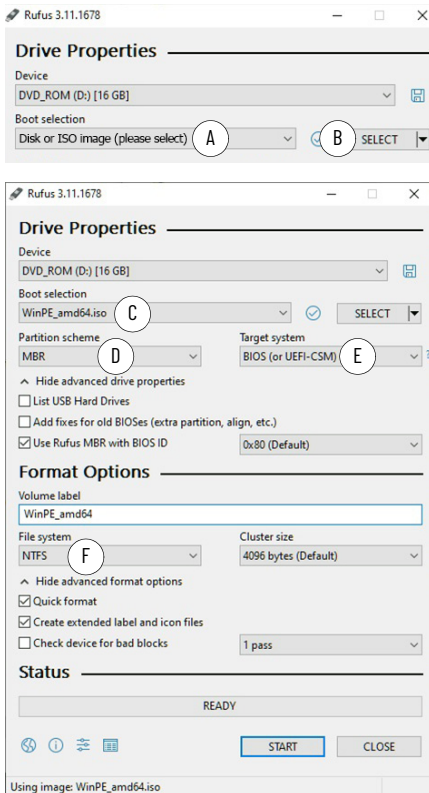

To create a bootable USB drive, perform the following steps.

1. Connect the USB drive to your computer.
2. To create a bootable USB drive, open the Rufus utility.
3. On Drive Properties, select 'Disk or ISO image (please select)' from the boot selection pull-down menu (A).
4. Click Select (B), and browse to your computer desktop.
5. Select the ISO file that you downloaded from the Rockwell Automation PCDC site. The ISO file name now appears in the boot selection field (C).
6. Select the following from other pull-down menus:
  - From partition scheme, select MBR (D)
  - From target system, select BIOS (or UEFI-CSM) (E)
  - From file system, select NTFS (F)
7. After the above fields have been changed, click Start.
8. A warning appears that any data on the drive will be erased; click OK.
9. Use the Status portion of the dialog box to monitor the boot progress.
10. When the boot process is completed, click Close.



The field 'Volume label' contains the name of the downloaded ISO file that you selected but you can change the volume name.

## Back Up the OS Image

To back up the OS image on your computer, perform the following steps.

### IMPORTANT

Before you can back up the OS image, you must first [Download the Accessory Files on page 24](#) and [Create a Bootable USB Drive on page 25](#).

To perform these steps, an external display, mouse, and keyboard must be connected to the computer.

1. Copy the BackupImage.bat file on your computer desktop to the bootable USB drive.
2. Restart the computer.
3. During POST, press F10 to access the Boot menu.
4. Use the down arrow to toggle down and select the bootable USB drive that you created, and then press Enter.





## Restore the OS Image

To restore the OS image on your computer, perform the following steps.

---

**IMPORTANT** Before you can restore the OS image, you must first [Download the Accessory Files on page 24](#) and [Create a Bootable USB Drive on page 25](#).  
When you restore the OS image, all files on your computer storage drive are erased.  
To perform these steps, an external display, mouse, and keyboard must be connected to the computer.

---

1. Copy the WIM and BAT files on your computer desktop to the bootable USB drive.
2. Restart the computer.
3. During POST, press F10 to access the Boot menu.
4. Use the down arrow to toggle down and select the bootable USB drive that you created, and then press Enter.



The Microsoft Windows Protective Environment (WinPE) then boots from the USB drive.

5. Navigate to the directory where the BAT file is located.  
For example, type **D:** and press Enter if you know that the BAT file is on the D drive.
6. Once in the directory, type **RestoreImageUEFI.bat NameFile.wim** where **NameFile** is the name of the file that you wish to restore.

---

**IMPORTANT** The image file name cannot have any space characters; use underscore characters instead.

---

The screen capture below is merely an example of a possible file name but it illustrates the correct character structure.

```
D:\>RestoreImageUEFI.bat System_Image-VersaView_6300_Windows_10_2019_LTSC.wim
```

7. After you have added that information, press Enter.  
You receive a confirmation screen similar to the following:

```
*****
* This script is going to delete all the data in the following device: *
* Name of Device: 240GB SATA Flash Drive *
* Capacity: 240 GB (1GB = 1000MB) *
* Are You sure you want to continue? (Y or N) *
*****
(Y or N):
```

---

**IMPORTANT** The device name and capacity of your computer can differ from what is shown in the above example.

---

8. If the targeted drive is correct, press **Y** and then Enter.  
The following script appears after the restoration process is completed.

```
Applying image
[=====100.0%=====]
The operation completed successfully.
Boot files successfully created.
D:\>
```

9. After the OS image is restored, do one of the following:
  - To restart the computer, type **exit** and then press Enter.
  - To shut down the computer, type **wpeutil shutdown** and then press Enter.

The OS image has been restored successfully to your computer storage drive.

## Update to a New UEFI

Sometimes a new UEFI is released to enhance the performance of your computer or to correct an anomaly. In such cases, you can download UEFI upgrades at the Rockwell Automation® Product Compatibility and Download Center (PCDC) website at <https://compatibility.rockwellautomation.com/Pages/home.aspx>.

### Verify or Create a FAT32-formatted USB Drive

To update the UEFI, you must use a FAT32-formatted USB drive. To verify if a USB drive is FAT32-formatted, perform the following steps.

---

**IMPORTANT** To perform these steps, an external display, keyboard, and FAT32-formatted USB drive must be connected to the computer.

---

1. Connect a USB drive to the computer.
2. In Windows Explorer, right-click on the USB drive icon and select Properties.

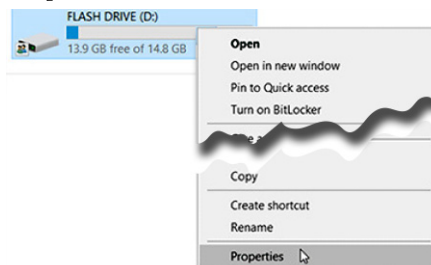

3. In Properties, verify if the file system is FAT32.

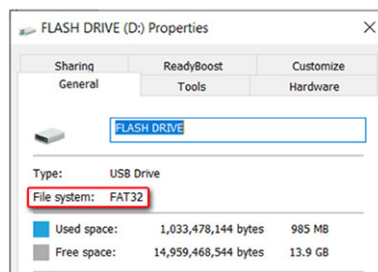

4. Click Cancel to exit Properties.
5. If the drive is FAT32-formatted, proceed to [Download the UEFI Update Files on page 29](#).

If the drive is not FAT32-formatted, proceed to [step 6](#).

---

**IMPORTANT** Before you proceed, verify that no content is on the USB drive. If the drive must be FAT32-formatted, any content on the drive is erased and lost.

---

6. Right-click on the drive icon and select Format.

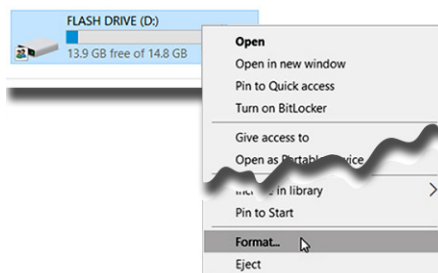

- In Format Flash Drive, select FAT32 from the file system pull-down menu.

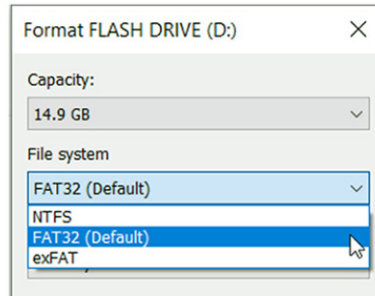

- Click Start to format the drive to FAT32. A confirmation box appears after formatting is completed; click OK.

## Download the UEFI Update Files

To update the UEFI, perform the following steps.

---

**IMPORTANT** To perform these steps, an external display, mouse, and keyboard must be connected to the computer.

---

- Access the Rockwell Automation PCDC website at: <https://compatibility.rockwellautomation.com/Pages/home.aspx>.
- On the home page, click Find Downloads.
- On the Find Downloads page, use your computer model as the search criteria.
- To find your UEFI file, follow the instructions on the PCDC site.
 

 You must be registered with the Rockwell Automation PCDC website to download files.  
You must accept a User Agreement before files can be downloaded.
- Download the UEFI file to the FAT32-formatted USB drive connected to your computer.

### *For VersaView 6300B-BMAx Box PCs and 6300T-BAx1 Thin Clients*

To update the UEFI on VersaView 6300B-BMAx box PCs and 6300T-BAx1 thin clients, perform the following steps.

- Verify that the following files are on your USB drive:
  - ShellFlash64.efi
  - UEFI upgrade (.cap) file
- Restart the computer.
- During POST, press F10 to enter the Boot menu.
- On the Boot menu, use the down (2) arrow to toggle down and select Internal Shell, and press Enter.



The internal UEFI shell appears.

```
UEFI Interactive Shell v2.1
EDK II
UEFI v2.50 (Phoenix Technologies Ltd., 0x12345678)
Mapping table
  FS1: Alias(s) :HD1j0b:;BLK6:
        PciRoot (0x0) /Pci (0x15,0x0) /USB (0x9,0x0) /HD (1,MBR,0xD941
  FS0: Alias(s) :HD0b0a1:;BLK1:
        PciRoot (0x0) /Pci (0x12,0x0) /Sata (0x1,0x0,0x0) /HD (1,GPT,C
```

5. Type **FSx:** (where 'x' is the number that is shown for your mapped USB drive) and press Enter.



To verify that you moved to the USB drive, use the command '**dir**' and confirm that the downloaded files are there.

6. To flash the UEFI, type **ShellFlash64.efi /file [FILE NAME].cap /force** and press Enter.

```
Shell> fs1:
FS1:\> ShellFlash64.efi /file MB962RW_20200624_001.cap /force

Phoenix SCT Flash for Shell U4.28.1.0, Build 181011
Copyright (c) 2011-2018 Phoenix Technologies Ltd.

The tool will start flashing in 5 seconds, press ESC to abort.
SecureFlash BIOS detected.
Read BIOS image from file.
Initialize Flash module.
```

The UEFI update procedure starts automatically.

7. Once the UEFI flash procedure is completed, the computer restarts automatically.

```
WARNING: System is going to shutdown and do capsule update!
WARNING: System will shutdown or reboot in 5 seconds!
```

The UEFI has been updated for 6300B-BMAx box PCs and 6300T-BAx1 box thin clients.

#### For VersaView 6300B-BMBx Box PCs

To update the UEFI on VersaView 6300B-BMBx box PCs, perform the following steps.

1. Verify that the following files are on your USB drive:
  - ShellFlash64.efi
  - AfuEfix64.efi
  - UEFI upgrade (.bin) file
2. Start or restart your computer.
3. During POST, press F2 to access the set-up utility.
4. Use the right (6) arrow to toggle over to the Advanced tab.
5. On Advanced, use the down (2) arrow to toggle down and select PCI-FW Configuration, and then press Enter.

```
Main  Advanced  Chipset  Security  Boot  Save & Exit
▶ Intel RC ACPI Settings
▶ CPU Configuration
▶ Power & Performance
▶ PCH-FW Configuration
▶ Thermal Configuration
▶ RTD3 settings
▶ Intel ICC
```

- On PCI-FW Configuration, toggle down and select Firmware Update Configuration, and then press Enter.

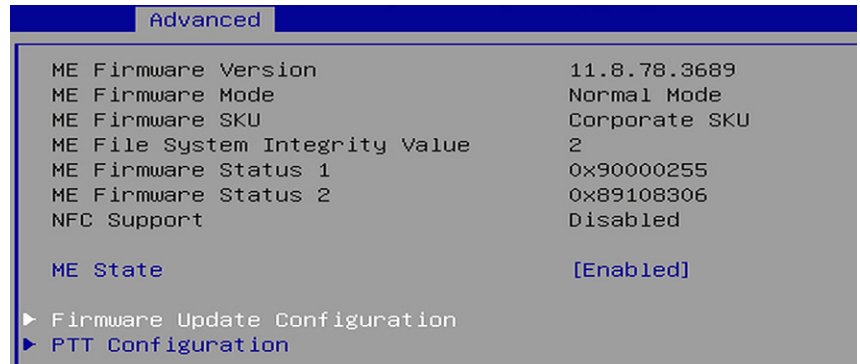

- Enable Me FW Image Re-Flash, and then press Enter.

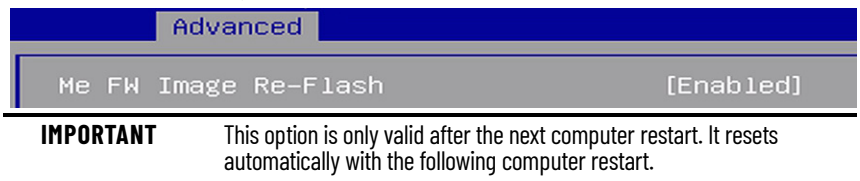

- A confirmation box appears; select Yes and press Enter.



- Restart the computer.
- During POST, press F2 to enter the set-up utility.
- Use the right (6) arrow to toggle over to the Save & Exit tab.
- On Save & Exit, use the down (2) arrow to toggle down and select 'Launch EFI Shell from the filesystem device', and then press Enter.

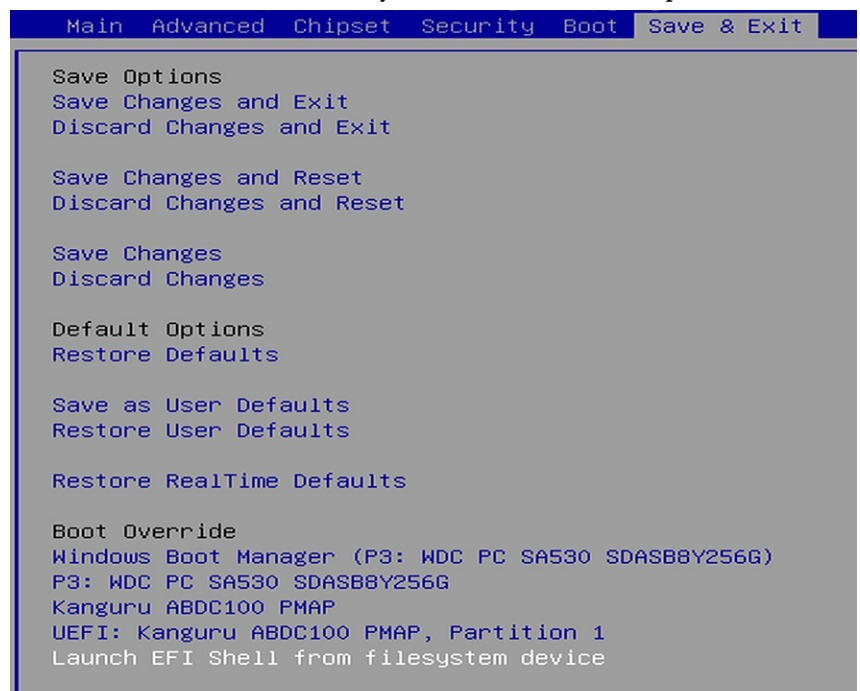

The internal UEFI shell appears.

```
UEFI Interactive Shell v2.1
EDK II
UEFI v2.70 (American Megatrends, 0x0005000C)
Mapping table
FS0: Alias(s):HD0q0b:;BLK1:
      PciRoot(0x0)/Pci(0x14,0x0)/USB(0x10,0x0)/HD(1,MBR,0xD9417
FS1: Alias(s):HD1d65535a1:;BLK4:
      PciRoot(0x0)/Pci(0x17,0x0)/Sata(0x3,0xFFFF,0x0)/HD(1,GPT,
```

13. Type **FSx:** (where 'x' is the number that is shown for your mapped USB drive) and press Enter.



To verify that you moved to the USB drive, use the command **'dir'** and confirm that the downloaded files are there.

14. To update the UEFI, type **AfuEfix64.efi "NAME\_OF\_THE\_BIN\_FILE.bin" /x /me /p /b /n** and press Enter.

```
Shell> fs0:
FS0:\> AfuEfix64.efi "9322082A.01_RA_MB1351_Signed.bin" /x /me /p /b /n
```



**WARNING:** Do not disconnect power from the computer until after the UEFI update procedure is completed.

Power loss during this procedure can render the computer inoperable.

15. Once the UEFI update procedure is completed, restart the computer.

**IMPORTANT**

In some instances, the computer restarts more than once before POST.

16. During POST, press F2 to enter the set-up utility.
17. Use the right (6) arrow to toggle over to the Save and Exit tab.
18. Use the down (2) arrow to toggle down and select a default option.

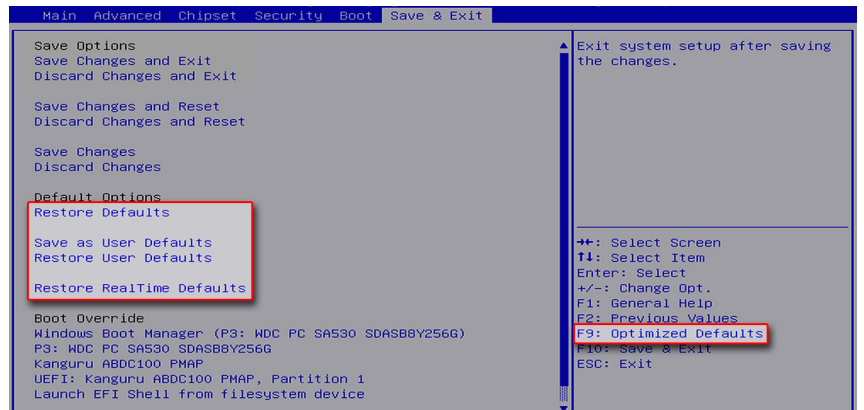

UEFI Setting	Function
Restore Defaults	Restores the default values for all set-up options.
Save as User Defaults	Save the changes done already as user defaults.
Restore User Defaults	Restores the user defaults to all set-up options.
Restore RealTime Defaults	Restores the real-time default settings.



You can also press F9 to select Optimized Defaults.

19. After you have selected the preferred UEFI setting, press F10 to save and exit.

The UEFI has been updated for 6300B-BMBx box PCs.



## Restore Factory Defaults Through a DIP Switch

This section is for when the UEFI set-up utility cannot be entered, which can happen when a created password is forgotten or a critical setup item was erroneously changed.

If the UEFI setup utility cannot be entered, then a DIP switch must be accessed and changed to reset to the UEFI factory-default settings.

### For VersaView 6300B-BMAx Box PCs and 6300T-BAX1 Thin Clients

To access and reset the DIP switch, perform the following steps.

---

**IMPORTANT** To perform these steps, an external display and keyboard must be connected to the computer.

---

1. Turn off the power to the computer.
2. Remove the computer cover as detailed in [For VersaView 6300B-BABx Box PCs and 6300T-BAX1 Thin Clients on page 43](#).
3. Locate the DIP switch bank SW1.

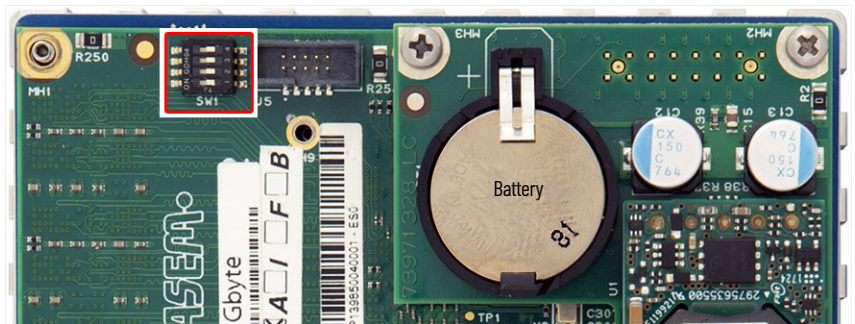

4. Move switch 3 of bank SW1 to on (factory reset).

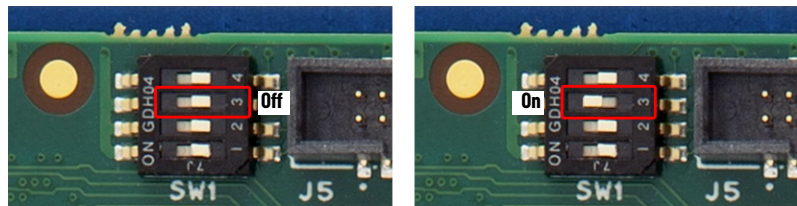

5. Reinstall the cover as detailed in [For VersaView 6300B-BABx Box PCs and 6300T-BAX1 Thin Clients on page 43](#).
6. Turn on power to the computer.
7. During POST, press F2 to enter the UEFI set-up utility.
8. When the computer enters the UEFI set-up utility, turn off power to the computer.
9. Remove the computer cover as detailed in [For VersaView 6300B-BABx Box PCs and 6300T-BAX1 Thin Clients on page 43](#).
10. Move switch 3 of bank SW1 to off.
11. Reinstall the cover as detailed in [For VersaView 6300B-BABx Box PCs and 6300T-BAX1 Thin Clients on page 43](#).
12. Turn on power to the computer.
13. During POST, press F2 to enter the UEFI set-up utility.
14. Use the right (6) arrow to toggle over to the Save and Exit tab.

## For VersaView 6300B-BMBx Box PCs

To access and reset the DIP switch, perform the following steps.

---

**IMPORTANT** To perform these steps, an external display and keyboard must be connected to the computer.

---

1. Turn off the power to the computer.
2. Remove the computer cover as detailed in [For VersaView 6300B-BMBx Box PCs on page 44](#).
3. Locate the DIP switch bank SW4.
4. Move switch 3 of bank SW4 to on (factory reset).

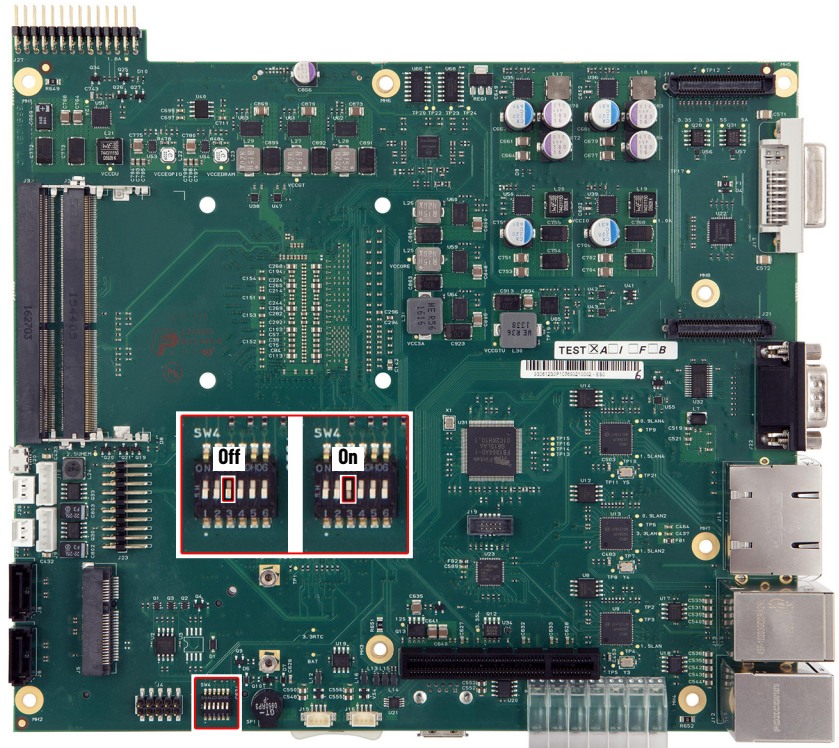

5. Reinstall the cover as detailed in [For VersaView 6300B-BMBx Box PCs on page 48](#).
6. Turn on power to the computer.
7. During startup, the following warning appears instead of POST.

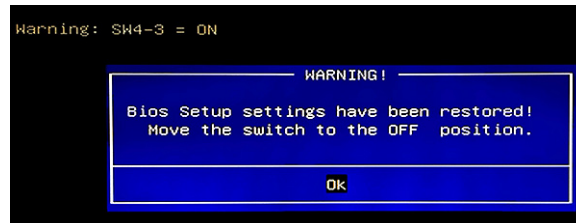

8. Press Enter.

---

**IMPORTANT** The blue Warning box disappears after you press OK, but the 'Warning: SW4-3 = ON' message remains until you turn off power to the computer.

---

9. Turn off power to the computer.
10. Remove the computer cover as detailed in [For VersaView 6300B-BMBx Box PCs on page 44](#).
11. Move switch 3 of bank SW4 to off.

12. Reinstall the cover as detailed in [For VersaView 6300B-BMBx Box PCs on page 48](#).
13. Turn on power to the computer.
14. During POST, press F2 to enter the UEFI set-up utility.
15. Use the right (6) arrow to toggle over to the Save and Exit tab.
16. Use the down (2) arrow to toggle down and select Restore RealTime Defaults or press F9 to select Optimized Defaults.

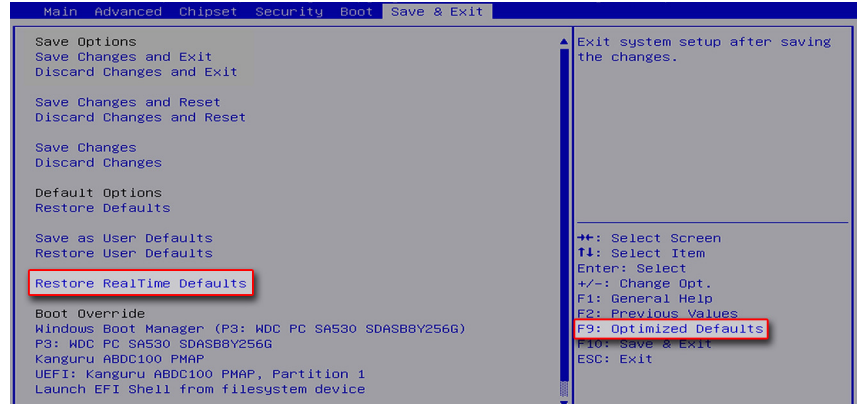

17. After you have selected the preferred UEFI setting, press F10 to save and exit.

**Notes:**

## **Clean the Box PC and Box Thin Client**

For optimal performance, it is important to clean the VersaView® 6300B box PC and 6300T thin clients periodically.

### **Clean the Vent Holes**

Perform the following steps to clean VersaView 6300B box PC and 6300T thin clients.

1. Disconnect power from the computer at the power source.
2. Vacuum dust and debris from any vent holes or heatsink.
3. Reconnect power to the computer at the power source.

## Notes:

## Troubleshoot the System

### Thermal Alarms

The VersaView® 6300B box PCs and 6300T thin clients have light-emitting diodes (LEDs) that light when the computer reaches its operating temperature. See [Table 2](#) and [Table 3](#) on [page 20](#) for where these LEDs are.

The internal temperature is measured near the CPU. The LEDs light when a thermal limit of 85 °C (185 °F) is reached.

Follow these steps to determine where an operating threshold has been reached.

1. Shut down the computer by using the appropriate method.  
For more information, see [Shut Down the VersaView 6300B Box PC on page 22](#).
2. Apply power to the computer.
3. During POST, press F2 to access the UEFI set-up utility:
4. On the Main screen, click Advanced.
5. On the Advanced screen, click Thermal.  
Use this menu to determine if there is an issue with internal voltages or component temperatures.

### Troubleshooting

Follow these steps to identify and isolate an issue with computer operation.

1. Shut down the computer by using the appropriate method.  
For more information, see [Shut Down the VersaView 6300B Box PC on page 22](#).
2. Disconnect power to the computer.
3. Disconnect all peripheral devices from the computer.
4. If a keyboard and mouse are used, verify that they are properly connected.
5. If an external display is used, verify that it is properly connected.
6. Connect power to the computer. During POST, one of three events occurs:
  - The startup process is completed.
  - A nonfatal error occurs and the related error message is displayed.
  - A fatal error occurs and the startup process terminates.

If	Then
The computer starts	Reconnect all peripheral devices one at a time until the issue occurs.
The issue is with a specific software or driver	Reinstall the software or driver.

If an issue cannot be identified by the above steps or a fatal error occurs, see [Rockwell Automation Support](#) on the back page for technical support.

## Load the System Defaults

If the computer fails after you make changes in the set-up menus, load the system default settings to correct the error. These default settings have been selected to optimize computer performance.

Follow these steps to load the system defaults.

---

**IMPORTANT** An external display, keyboard, and mouse must be connected to perform these steps.

---

1. Restart the computer as specified in [Restart or Reset the VersaView 6300B Box PC on page 21](#).
2. During POST, press F2 to access the UEFI set-up utility.
3. On the Main screen, click Exit.
4. On the Exit screen, press the down arrow key to access Load Optimized Defaults.
5. Press Enter to select Load Optimized Defaults, which are the system defaults.
6. Press F10 to save your changes and exit.  
The change resets the system automatically.

## Ship or Transport the Computer

If you must ship the computer via common carrier or otherwise transport it to another location for service or any other reason, you must first uninstall the computer and place it in its original packing material.



**ATTENTION:** Do not ship or transport the computer when it is installed in a machine, panel, or rack. To avoid damage to the computer, you must uninstall the computer and place it in its original packing material before you ship it.

Rockwell Automation is not responsible for damage to a computer that is shipped or transported while installed in a machine, panel, or rack.

---

## Dispose of the Computer



At the end of its life, collect the computer separately from any unsorted municipal waste.

---

You cannot dispose of computer equipment like other waste material. Most computers and monitors contain heavy metals that can contaminate the earth. Therefore, check with local health and sanitation agencies for ways to dispose monitor equipment safely.

When a storage drive is part of what you plan to dispose, then erase any data on it permanently or destroy the drive before it is disposed.



## Replace Components

VersaView® 6300B box PC and 6300T thin clients have replacement parts and upgrade accessories. This chapter explains how to replace or add these components to the box PC or box thin clients.

### Replacement Parts

You can view a list of replacement parts at <https://www.rockwellautomation.com/en-us/products/hardware/allen-bradley/industrial-computers-monitors/industrial-computers.html>.

Review the specifications of a new component before you install it to verify that it is compatible with the computer. Record the model, serial number, and any other pertinent information of new components for future reference.

---

**IMPORTANT** We recommend that you use only Allen-Bradley® approved replacement parts.

---

### Voltage Precautions

Disconnect all power to the computer before you install or remove components.



**SHOCK HAZARD:** Failure to disconnect power can result in damage to the computer.



**RISQUE D'ÉLECTROCUTION:** Couper l'alimentation électrique afin d'éviter d'endommager l'ordinateur.

### Electrostatic Discharge Precautions



**ATTENTION:** Electrostatic discharge (ESD) can damage static-sensitive devices or microcircuitry:

- Disconnect all power before you work on the computer as detailed in [Voltage Precautions](#).
- Observe proper packaging and grounding techniques to help prevent damage.

Follow these ESD precautions:

- Transport the computer and replacement parts in static-safe containers, such as conductive tubes, bags, or boxes.
- Keep electrostatic-sensitive parts in their containers until they arrive at the designated static-free work area.
- Cover the designated work area with approved static-dissipating material:
  - Use an anti-static wriststrap that is connected to the work surface.
  - Use properly grounded tools and equipment.

- Keep the designated work area free of nonconductive materials, such as ordinary plastic assembly aids and foam packing.
- Avoid contact with pins, leads, or circuitry.
- Always hold components with a printed circuit board (PCB) by its edges and place it with the assembly side down.

## Pre-configuration

---

**IMPORTANT**

Before you install hardware or perform maintenance procedures that require access to internal components, we recommend that you first back up all computer data to avoid loss.

---



**ATTENTION:** Make sure to read and understand all installation and removal procedures before you configure the computer hardware.

---

Follow these steps before you remove the computer cover or replace a hardware component.

1. Shut down the computer and all peripherals that are connected to it.
2. To avoid exposure to high energy levels, disconnect all cables from power outlets.  
If necessary, label each cable to expedite reassembly.
3. Disconnect all peripheral cables from the I/O ports.
4. Loosen the mounting screws and remove the computer from its mounting.

## Post-configuration

Follow these steps after you install or replace a hardware component.

1. Reinstall the computer to its mounting.
2. Tighten the mounting screws.
3. Reinstall any peripherals and system cables that were previously removed.
4. Reconnect all external cables and power to the computer.
5. Turn on the main power switch or breaker.

## Remove the Cover

To install, replace, or upgrade internal computer components, you must first remove the cover.

### For VersaView 6300B-BABx Box PCs and 6300T-BAx1 Thin Clients



You need the following tools to remove the cover:

- #2 Phillips screwdriver to loosen the four mounting screws
- Torx T6 screwdriver to remove the six cover screws

1. Follow the steps for [Pre-configuration on page 42](#).
2. Remove the four screws that secure the mounting bracket to the back side of the computer.



3. Remove the mounting bracket.
4. Remove the six screws that secure the computer cover.

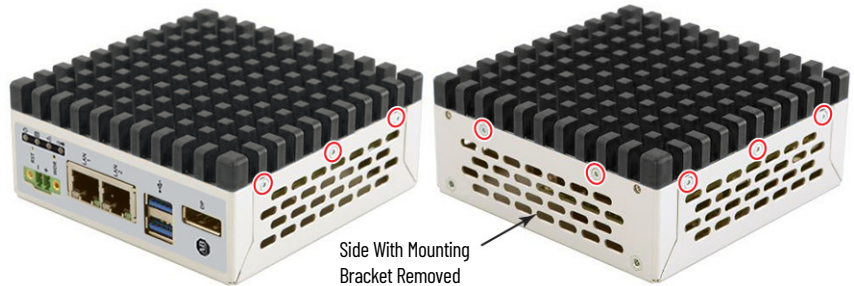

5. Remove the cover, and place it on a static-free surface so the motherboard is facing up.



6. After you install, replace, or upgrade internal computer components, perform the steps in [Reinstall the Cover on page 47](#).

## For VersaView 6300B-BMBx Box PCs



You need a #2 Phillips screwdriver to remove the six cover screws.

1. Follow the steps for [Pre-configuration on page 42](#).
2. With the screwdriver, remove these six screws that secure the left side cover.

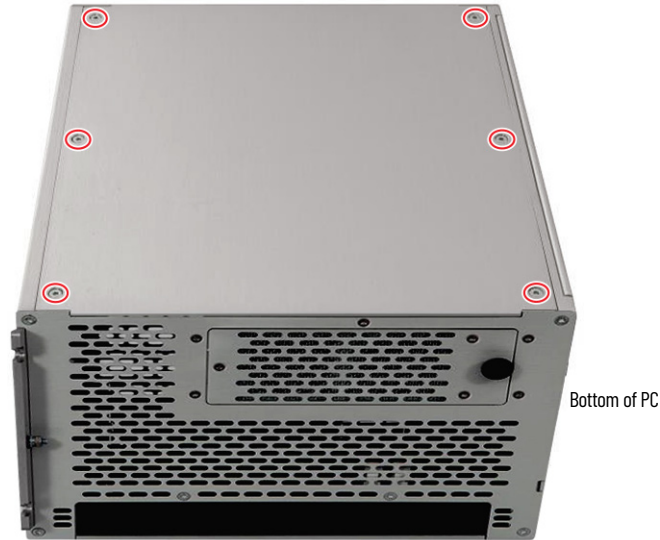

3. After you install, replace, or upgrade internal computer components, perform the steps in [Reinstall the Cover on page 47](#).

## Replace the Battery

### IMPORTANT

Battery replacement requires work near static-sensitive equipment. Therefore, only service personnel must replace the battery.

All VersaView 6300B box PCs and 6300T box thin clients use nonvolatile memory that requires a real-time clock (RTC) lithium battery to retain system information when power is removed.

This battery must be replaced during the life of the computer. The battery life depends on the amount of time the computer is on, or on-time.

The thermal light-emitting diode (LED) on the front of all VersaView 6300B box PCs and 6300T box thin clients flashes red when the RTC battery is lower than 2.5V.

For the thermal LED locations, see [Table 2](#) and [Table 3](#) on [page 20](#).

Follow these steps to replace the RTC battery.

## For VersaView 6300B-BABx Box PCs and 6300T-BAx1 Thin Clients

1. To access the battery, first perform the steps in [For VersaView 6300B-BABx Box PCs and 6300T-BAx1 Thin Clients on page 43](#).

2. Locate the RTC battery on the upper tier of the motherboard.

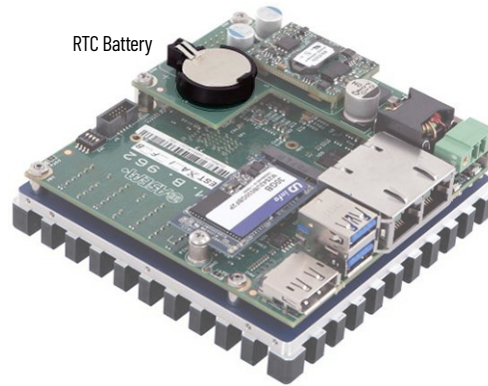

3. Remove the battery and replace it with the same model (Lithium CR2032 3v coin).

Install the new battery so the positive polarity side faces up.



**WARNING:** Replace the battery with the same model. There is a risk of explosion if the battery is replaced with the wrong type.



**AVERTISSEMENT:** Remplacer la batterie par le même modèle, sinon il y a risque d'explosion.

4. Follow the steps in [Post-configuration on page 42](#).

**IMPORTANT**

If you replace the battery, then all UEFI settings return to their default settings. UEFI settings other than default must be reconfigured after you replace the battery.



At the end of its life, collect the battery that is contained in this computer separately from any unsorted municipal waste.

## For VersaView 6300B-BMBx Box PCs

The RTC battery is available from the front panel of these box PCs.



A metal extractor is supplied with these box PCs, which you use to remove the battery holder.

1. Follow the steps for [Pre-configuration on page 42](#).
2. Open the right front panel door to access the battery holder.

- Use the metal extractor to latch onto the back (open) side of the battery holder.



- Extract the battery holder from the computer.
- Remove the battery and replace it with the same model (Lithium CR2032 3v coin).  
Insert the new battery so the positive polarity side is on the back side of the battery holder.



**WARNING:** Replace the battery with the same model. There is a risk of explosion if the battery is replaced with the wrong type.



**AVERTISSEMENT:** Remplacer la batterie par le même modèle, sinon il y a risque d'explosion.

- Reinstall the battery holder in the computer.

**IMPORTANT**

If you replace the battery, then all UEFI settings return to their default settings. UEFI settings other than default must be reconfigured after you replace the battery.



At the end of its life, collect the battery that is contained in this computer separately from any unsorted municipal waste.

## Reinstall the Cover

To reinstall the cover, perform the following steps.

### For VersaView 6300B-BABx Box PCs and 6300T-BAx1 Thin Clients



You need the following tools to replace the cover:

- #2 Phillips screwdriver to reinstall the four mounting screws
- Torx T6 screwdriver to reinstall the six cover screws

1. Turn the motherboard over and return the cover to the computer. Reinstall the cover so that the I/O connections on the motherboard align with the corresponding openings on the front panel of the computer.
2. Reinstall and tighten the six screws that secure the computer cover.

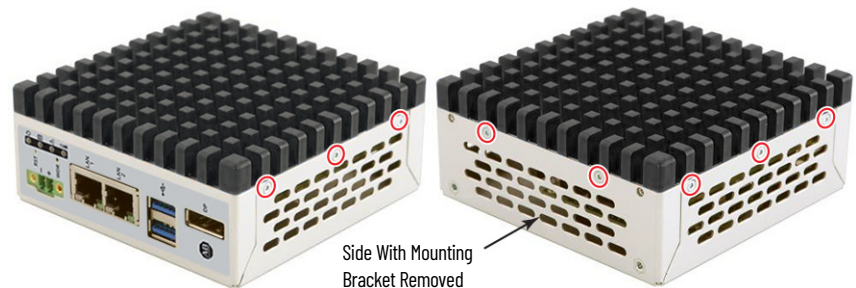

3. Reinstall the mounting bracket to the back side of the computer.
  - a. Align the mounting bracket so the end with the ground screw is at the bottom.  
For the correct alignment, see [Figure 1 on page 10](#).
  - b. Reinstall the four screws that secure the mounting bracket to the back side of the computer.  
Torque each screw to a value of 0.4...0.5 N•m (3.5...4.4 ft•lb).
4. Follow the steps for [Post-configuration on page 42](#).

## For VersaView 6300B-BMBx Box PCs



You need a #2 Phillips screwdriver to reinstall the six cover screws.

1. Reinstall the left side cover.
2. With the screwdriver, reinstall the six screws that secure the left side cover.

Torque each screw to a value of 0.4...0.5 N•m (3.5...4.4 ft•lb).



3. Follow steps 3...5 for [Post-configuration on page 42](#).





# Rockwell Automation Support

Use these resources to access support information.

<b>Technical Support Center</b>	Find help with how-to videos, FAQs, chat, user forums, and product notification updates.	<a href="http://rok.auto/support">rok.auto/support</a>
<b>Knowledgebase</b>	Access Knowledgebase articles.	<a href="http://rok.auto/knowledgebase">rok.auto/knowledgebase</a>
<b>Local Technical Support Phone Numbers</b>	Locate the telephone number for your country.	<a href="http://rok.auto/phonesupport">rok.auto/phonesupport</a>
<b>Literature Library</b>	Find installation instructions, manuals, brochures, and technical data publications.	<a href="http://rok.auto/literature">rok.auto/literature</a>
<b>Product Compatibility and Download Center (PCDC)</b>	Download firmware, associated files (such as AOP, EDS, and DTM), and access product release notes.	<a href="http://rok.auto/pcdc">rok.auto/pcdc</a>

## Documentation Feedback

Your comments help us serve your documentation needs better. If you have any suggestions on how to improve our content, complete the form at [rok.auto/docfeedback](http://rok.auto/docfeedback).

## Waste Electrical and Electronic Equipment (WEEE)



At the end of its life, collect this equipment separately from any unsorted municipal waste.





Rockwell Automation maintains current product environmental information on its website at [rok.auto/pec](http://rok.auto/pec).

Allen-Bradley, expanding human possibility, FactoryTalk, Rockwell Automation, ThinManager, and VersaView are trademarks of Rockwell Automation, Inc.

Microsoft and Windows are trademarks of Microsoft Corp.

Trademarks not belonging to Rockwell Automation are property of their respective companies.

Rockwell Otomasyon Ticaret A.Ş. Kar Plaza İş Merkezi E Blok Kat:6 34752, İçerenköy, İstanbul, Tel: +90 (216) 5698400 EEE Yönetmeliğine Uygundur

Connect with us.    

**rockwellautomation.com** ————— expanding **human possibility**<sup>™</sup>

AMERICAS: Rockwell Automation, 1201 South Second Street, Milwaukee, WI 53204-2496 USA, Tel: (1) 414.382.2000, Fax: (1) 414.382.4444

EUROPE/MIDDLE EAST/AFRICA: Rockwell Automation NV, Pegasus Park, De Kleetlaan 12a, 1831 Diegem, Belgium, Tel: (32) 2 663 0600, Fax: (32) 2 663 0640

ASIA PACIFIC: Rockwell Automation, Level 14, Core F, Cyberport 3, 100 Cyberport Road, Hong Kong, Tel: (852) 2887 4788, Fax: (852) 2508 1846

Publication 6300B-UM001B-EN-P - December 2020

Supersedes Publication 6300B-UM001A-EN-P - July 2020

Copyright © 2020 Rockwell Automation, Inc. All rights reserved. Printed in the U.S.A.