

# Compact 5000 I/O Serial Module

Catalog Number 5069-SERIAL

Topic	Page
Install a System	5
Required Components	5
Install the Module	6
Install the End Cap	7
Connect the Serial Cable	7
Power the System	8
Remove the Module	8
Specifications	11
Additional Resources	11

The Compact 5000™ I/O serial module provides a network interface to RS-232, RS-422, and RS-485 devices.

The modules are used as local I/O modules with CompactLogix™ 5380 or Compact GuardLogix® 5380 controllers or as remote I/O modules with CompactLogix 5380 or Compact GuardLogix 5380 controllers and some other Logix 5000™ controllers. The modules are configured with the Studio 5000 Logix Designer® application.

For more information on how to use a 5069-SERIAL module, see the publications that are listed in [Additional Resources on page 11](#).



**ATTENTION:** Read this document and the documents listed in the Additional Resources section about installation, configuration and operation of this equipment before you install, configure, operate or maintain this product. Users are required to familiarize themselves with installation and wiring instructions in addition to requirements of all applicable codes, laws, and standards.

Activities including installation, adjustments, putting into service, use, assembly, disassembly, and maintenance are required to be carried out by suitably trained personnel in accordance with applicable code of practice.

If this equipment is used in a manner not specified by the manufacturer, the protection provided by the equipment may be impaired.

**注意:** 在安装、配置、操作和维护本产品前, 请阅读本文档以及“其他资源”部分列出的有关设备安装、配置和操作的相应文档。除了所有适用规范、法律和标准的相关要求之外, 用户还必须熟悉安装和接线说明。

安装、调整、投运、使用、组装、拆卸和维护等各项操作必须由经过适当训练的专业人员按照适用的操作规范实施。

如果未按照制造商指定的方式使用该设备, 则可能会损害设备提供的保护。

**ATENCIÓN:** Antes de instalar, configurar, poner en funcionamiento o realizar el mantenimiento de este producto, lea este documento y los documentos listados en la sección Recursos adicionales acerca de la instalación, configuración y operación de este equipo. Los usuarios deben familiarizarse con las instrucciones de instalación y cableado y con los requisitos de todos los códigos, leyes y estándares vigentes.

El personal debidamente capacitado debe realizar las actividades relacionadas a la instalación, ajustes, puesta en servicio, uso, ensamblaje, desensamblaje y mantenimiento de conformidad con el código de práctica aplicable.

Si este equipo se usa de una manera no especificada por el fabricante, la protección provista por el equipo puede resultar afectada.

**ATENÇÃO:** Leia este e os demais documentos sobre instalação, configuração e operação do equipamento que estão na seção Recursos adicionais antes de instalar, configurar, operar ou manter este produto. Os usuários devem se familiarizar com as instruções de instalação e fiação além das especificações para todos os códigos, leis e normas aplicáveis.

É necessário que as atividades, incluindo instalação, ajustes, colocação em serviço, utilização, montagem, desmontagem e manutenção sejam realizadas por pessoal qualificado e especializado, de acordo com o código de prática aplicável.

Caso este equipamento seja utilizado de maneira não estabelecida pelo fabricante, a proteção fornecida pelo equipamento pode ficar prejudicada.

**ВНИМАНИЕ:** Перед тем как устанавливать, настраивать, эксплуатировать или обслуживать данное оборудование, прочитайте этот документ и документы, перечисленные в разделе «Дополнительные ресурсы». В этих документах изложены сведения об установке, настройке и эксплуатации данного оборудования. Пользователи обязаны ознакомиться с инструкциями по установке и прокладке соединений, а также с требованиями всех применимых норм, законов и стандартов.

Все действия, включая установку, наладку, ввод в эксплуатацию, использование, сборку, разборку и техническое обслуживание, должны выполняться обученным персоналом в соответствии с применимыми нормами и правилами.

Если оборудование используется не предусмотренным производителем образом, защита оборудования может быть нарушена.

**注意:** 本製品を設置、構成、稼働または保守する前に、本書および本機器の設置、設定、操作についての参考資料の該当箇所に記載されている文書に目を通してください。ユーザは、すべての該当する条例、法律、規格の要件に加えて、設置および配線の手順に習熟している必要があります。

設置調整、運転の開始、使用、組立て、解体、保守を含む諸作業は、該当する実施規則に従って訓練を受けた適切な作業員が実行する必要があります。

本機器が製造メーカーにより指定されていない方法で使用されている場合、機器により提供されている保護が損なわれる恐れがあります。

**ACHTUNG:** Lesen Sie dieses Dokument und die im Abschnitt „Weitere Informationen“ aufgeführten Dokumente, die Informationen zu Installation, Konfiguration und Bedienung dieses Produkts enthalten, bevor Sie dieses Produkt installieren, konfigurieren, bedienen oder warten. Anwender müssen sich neben den Bestimmungen aller anwendbaren Vorschriften, Gesetze und Normen zusätzlich mit den Installations- und Verdrahtungsanweisungen vertraut machen.

Arbeiten im Rahmen der Installation, Anpassung, Inbetriebnahme, Verwendung, Montage, Demontage oder Instandhaltung dürfen nur durch ausreichend geschulte Mitarbeiter und in Übereinstimmung mit den anwendbaren Ausführungsvorschriften vorgenommen werden.

Wenn das Gerät in einer Weise verwendet wird, die vom Hersteller nicht vorgesehen ist, kann die Schutzfunktion beeinträchtigt sein.

**ATTENTION :** Lisez ce document et les documents listés dans la section Ressources complémentaires relatifs à l'installation, la configuration et le fonctionnement de cet équipement avant d'installer, configurer, utiliser ou entretenir ce produit. Les utilisateurs doivent se familiariser avec les instructions d'installation et de câblage en plus des exigences relatives aux codes, lois et normes en vigueur.

Les activités relatives à l'installation, le réglage, la mise en service, l'utilisation, l'assemblage, le démontage et l'entretien doivent être réalisées par des personnes formées selon le code de pratique en vigueur.

Si cet équipement est utilisé d'une façon qui n'a pas été définie par le fabricant, la protection fournie par l'équipement peut être compromise.

**주의:** 본 제품 설치, 설정, 작동 또는 유지 보수하기 전에 본 문서를 포함하여 설치, 설정 및 작동에 관한 참고 자료 섹션의 문서들을 반드시 읽고 숙지하십시오. 사용자는 모든 관련 규정, 법규 및 표준에서 요구하는 사항에 대해 반드시 설치 및 배선 지침을 숙지해야 합니다.

설치, 조정, 가동, 사용, 조립, 분해, 유지보수 등 모든 작업은 관련 규정에 따라 적절한 교육을 받은 사용자를 통해서만 수행해야 합니다.

본 장비를 제조사가 명시하지 않은 방법으로 사용하면 장비의 보호 기능이 손상될 수 있습니다.

**ATTENZIONE** Prima di installare, configurare ed utilizzare il prodotto, o effettuare interventi di manutenzione su di esso, leggere il presente documento ed i documenti elencati nella sezione "Altre risorse", riguardanti l'installazione, la configurazione ed il funzionamento dell'apparecchiatura. Gli utenti devono leggere e comprendere le istruzioni di installazione e cablaggio, oltre ai requisiti previsti dalle leggi, codici e standard applicabili.

Le attività come installazione, regolazioni, utilizzo, assemblaggio, disassemblaggio e manutenzione devono essere svolte da personale adeguatamente addestrato, nel rispetto delle procedure previste.

Qualora l'apparecchio venga utilizzato con modalità diverse da quanto previsto dal produttore, la sua funzione di protezione potrebbe venire compromessa.

**DIKKAT:** Bu ürünün kurulumu, yapılandırılması, işletilmesi veya bakımı öncesinde bu dokümanı ve bu ekipmanın kurulumu, yapılandırılması ve işletimi ile ilgili İlav Kaynaklar bölümünde yer listelenmiş dokümanları okuyun. Kullanıcılar yürürlükteki tüm yönetmelikler, yasalar ve standartların gereksinimlerine ek olarak kurulum ve kablolama talimatlarını da öğrenmek zorundadır.

Kurulum, ayarlama, hizmet alma, kulanma, parçaları birleştirme, parçaları sökme ve kabloları sökme gibi aktiviteler sadece uygun eğitimleri almış kişiler tarafından yürürlükteki uygulama yönetmeliklerine uygun şekilde yapılabilir.

Bu ekipman üretici tarafından belirlenmiş amacın dışında kullanılırsa, ekipman tarafından sağlanan koruma bozulabilir.

**注意事項:** 在安装、設定、操作或維護本產品前, 請先閱讀此文件以及列於「其他資源」章節中有關安裝、設定與操作此設備的文件。使用者必須熟悉安裝和配線指示, 並符合所有法規、法律和標準要求。

包括安裝、調整、交付使用、使用、組裝、拆卸和維護等動作都必須交由已經過適當訓練的人員進行, 以符合適用的實作法規。

如果將設備用於非製造商指定的用途時, 可能會造成設備所提供的保護功能受損。

**POZOR:** Než začnete instalovat, konfigurovat či provozovat tento výrobek nebo provádět jeho údržbu, přečtěte si tento dokument a dokumenty uvedené v části Dodatečné zdroje ohledně instalace, konfigurace a provozu tohoto zařízení. Uživatelé se musejí vedle požadavků všech relevantních vyhlášek, zákonů a norem nutně seznámit také s pokyny pro instalaci elektrické zapojení.

Činnosti zahrnující instalaci, nastavení, uvedení do provozu, užívání, montáž, demontáž a údržbu musí vykonávat vhodně proškolený personál v souladu s příslušnými prováděcími předpisy.

Pokud se toto zařízení používá způsobem neodpovídajícím specifikaci výrobce, může být narušena ochrana, kterou toto zařízení poskytuje.

**UWAGA:** Przed instalacją, konfiguracją, użytkowaniem lub konserwacją tego produktu należy przeczytać niniejszy dokument oraz wszystkie dokumenty wymienione w sekcji Dodatkowe źródła omawiające instalację, konfigurację i procedury użytkowania tego urządzenia. Użytkownicy mają obowiązek zapoznać się z instrukcjami dotyczącymi instalacji oraz oprzewodowania, jak również z obowiązującymi kodeksami, prawem i normami.

Działania obejmujące instalację, regulację, przekazanie do użytkowania, użytkowanie, montaż, demontaż oraz konserwację muszą być wykonywane przez odpowiednio przeszkolony personel zgodnie z obowiązującym kodeksem postępowania.

Jeśli urządzenie jest użytkowane w sposób inny niż określony przez producenta, zabezpieczenie zapewniane przez urządzenie może zostać ograniczone.

**BSI** Las detta dokument samt dokumentet, som står listat i avsnittet Övriga resurser, om installation, konfigurering och drift av denna utrustning innan du installerar, konfigurerar eller börjar använda eller utföra underhållsarbete på produkten. Användare måste bekanta sig med instruktioner för installation och kabeldragning, förutom krav enligt gällande koder, lagar och standarder.

Åtgärder som installation, justering, service, användning, montering, demontering och underhållsarbete måste utföras av personal med lämplig utbildning enligt lämpligt bruk.



Om denna utrustning används på ett sätt som inte anges av tillverkaren kan det hända att utrustningens skyddsanordningar försätts ur funktion.

**LET OP:** Lees dit document en de documenten die genoemd worden in de paragraaf Aanvullende informatie over de installatie, configuratie en bediening van deze apparatuur voordat u dit product installeert, configureert, bedient of onderhoudt. Gebruikers moeten zich vertrouwd maken met de installatie en de bedringsinstructies, naast de vereisten van alle toepasselijke regels, wetten en normen.

Activiteiten zoals het installeren, afstellen, in gebruik stellen, gebruiken, monteren, demonteren en het uitvoeren van onderhoud mogen uitsluitend worden uitgevoerd door hiervoor opgeleid personeel en in overeenstemming met de geldende praktijkregels.

Indien de apparatuur wordt gebruikt op een wijze die niet is gespecificeerd door de fabrikant, dan bestaat het gevaar dat de beveiliging van de apparatuur niet goed werkt.

## North American Hazardous Location Approval

The following information applies when operating this equipment in hazardous locations.	Informations sur l'utilisation de cet équipement en environnements dangereux.
<p>Products marked "CL I, DIV 2, GP A, B, C, D" are suitable for use in Class I Division 2 Groups A, B, C, D, Hazardous Locations and nonhazardous locations only. Each product is supplied with markings on the rating nameplate indicating the hazardous location temperature code. When combining products within a system, the most adverse temperature code (lowest "T" number) may be used to help determine the overall temperature code of the system. Combinations of equipment in your system are subject to investigation by the local Authority Having Jurisdiction at the time of installation.</p>	<p>Les produits marqués "CL I, DIV 2, GP A, B, C, D" ne conviennent qu'à une utilisation en environnements de Classe I Division 2 Groupes A, B, C, D dangereux et non dangereux. Chaque produit est livré avec des marquages sur sa plaque d'identification qui indiquent le code de température pour les environnements dangereux. Lorsque plusieurs produits sont combinés dans un système, le code de température le plus défavorable (code de température le plus faible) peut être utilisé pour déterminer le code de température global du système. Les combinaisons d'équipements dans le système sont sujettes à inspection par les autorités locales qualifiées au moment de l'installation.</p>
 <p><b>WARNING:</b> <b>Explosion Hazard –</b></p> <ul style="list-style-type: none"> <li>Do not disconnect equipment unless power has been removed or the area is known to be nonhazardous.</li> <li>Do not disconnect connections to this equipment unless power has been removed or the area is known to be nonhazardous. Secure any external connections that mate to this equipment by using screws, sliding latches, threaded connectors, or other means provided with this product.</li> <li>Substitution of components may impair suitability for Class I, Division 2.</li> <li>If this product contains batteries, they must only be changed in an area known to be nonhazardous.</li> </ul>	 <p><b>AVERTISSEMENT:</b> <b>Risque d'Explosion –</b></p> <ul style="list-style-type: none"> <li>Couper le courant ou s'assurer que l'environnement est classé non dangereux avant de débrancher l'équipement.</li> <li>Couper le courant ou s'assurer que l'environnement est classé non dangereux avant de débrancher les connecteurs. Fixer tous les connecteurs externes reliés à cet équipement à l'aide de vis, loquets coulissants, connecteurs filetés ou autres moyens fournis avec ce produit.</li> <li>La substitution de composants peut rendre cet équipement inadapté à une utilisation en environnement de Classe I, Division 2.</li> <li>S'assurer que l'environnement est classé non dangereux avant de changer les piles.</li> </ul>

## Environment and Enclosure



### ATTENTION:

This equipment is intended for use in a Pollution Degree 2 industrial environment, in overvoltage Category II applications (as defined in EN/IEC 60664-1), at altitudes up to 2000 m (6562 ft) without derating.

This equipment is not intended for use in residential environments and may not provide adequate protection to radio communication services in such environments.

This equipment is supplied as open-type equipment for indoor use. It must be mounted within an enclosure that is suitably designed for those specific environmental conditions that will be present and appropriately designed to prevent personal injury resulting from accessibility to live parts. The enclosure must have suitable flame-retardant properties to prevent or minimize the spread of flame, complying with a flame spread rating of 5VA or be approved for the application if nonmetallic. The interior of the enclosure must be accessible only by the use of a tool. Subsequent sections of this publication may contain more information regarding specific enclosure type ratings that are required to comply with certain product safety certifications.

In addition to this publication, see the following:

- Industrial Automation Wiring and Grounding Guidelines, publication [1770-4.1](#), for more installation requirements.
- NEMA Standard 250 and EN/IEC 60529, as applicable, for explanations of the degrees of protection provided by enclosures.

## Special Conditions for Safe Use



### WARNING:

- This equipment is not resistant to sunlight or other sources of UV radiation.
- This equipment shall be mounted in an ATEX/IECEx Zone 2 certified enclosure with a minimum ingress protection rating of at least IP54 (in accordance with EN/IEC 60079-15) and used in an environment of not more than Pollution Degree 2 (as defined in EN/IEC 60664-1) when applied in Zone 2 environments. The enclosure must be accessible only by the use of a tool.
- This equipment shall be used within its specified ratings defined by Rockwell Automation.
- Provision shall be made to prevent the rated voltage from being exceeded by transient disturbances of more than 140% of the peak rated voltage when applied in Zone 2 environments.
- The instructions in the user manual shall be observed.
- This equipment must be used only with ATEX/IECEx certified Rockwell Automation backplanes.
- Secure any external connections that mate to this equipment by using screws, sliding latches, threaded connectors, or other means provided with this product.
- Do not disconnect equipment unless power has been removed or the area is known to be nonhazardous.
- Earthing is accomplished through mounting of modules on rail.
- Devices shall be used in an environment of not more than Pollution Degree 2.
- When installed in a non-hazardous area, the module may alternatively be installed in a controlled environment that provides equivalent protection.
- When used in a Class I, Division 2, hazardous location, this equipment must be mounted in a suitable enclosure with proper wiring method that complies with the governing electrical codes.
- Do not touch. Product surfaces may reach high temperatures.

## Prevent Electrostatic Discharge

---



**ATTENTION:** This equipment is sensitive to electrostatic discharge, which can cause internal damage and affect normal operation. Follow these guidelines when you handle this equipment:

- Touch a grounded object to discharge potential static.
  - Wear an approved grounding wriststrap.
  - Do not touch connectors or pins on component boards.
  - Do not touch circuit components inside the equipment.
  - Use a static-safe workstation, if available.
  - Store the equipment in appropriate static-safe packaging when not in use.
- 

## Electrical Safety Considerations

---



**ATTENTION:**

- In case of malfunction or damage, no attempts at repair should be made. The module should be returned to the manufacturer for repair. Do not dismantle the module.
  - This equipment is certified for use only within the surrounding air temperature range of 0 °C...+60 °C (+32 °F...+140 °F). The equipment must not be used outside of this range.
  - Use only a soft dry anti-static cloth to wipe down equipment. Do not use any cleaning agents.
  - All wiring must comply with applicable electrical installation requirements (e.g., N.E.C. article 501-4(b)).
  - Wire conductor and insulation ratings shall support minimum temperature rating of 85 °C (185 °F)
- 

## European Hazardous Location Approval

---

The following applies to products marked   II 3 G. Such modules:

- Are Equipment Group II, Equipment Category 3, and comply with the Essential Health and Safety Requirements relating to the design and construction of such equipment given in Annex II to Directive 2014/34/EU. See the EC Declaration of Conformity at <http://www.rockwellautomation.com/products/certification> for details.
  - The type of protection is “Ex nA IIC T4 Gc” according to EN 60079-15.
  - Comply to Standards EN 60079-0:2012+A11:2013, EN 60079-15:2010, reference certificate number <DEMKO 15ATEX 1484X>.
  - Are intended for use in areas in which explosive atmospheres caused by gases, vapors, mists, or air are unlikely to occur, or are likely to occur only infrequently and for short periods. Such locations correspond to Zone 2 classification according to ATEX directive 2014/34/EU.
- 

## IEC Hazardous Location Approval

---

The following applies to products with IECEx certification:

- Are intended for use in areas in which explosive atmospheres caused by gases, vapors, mists, or air are unlikely to occur, or are likely to occur only infrequently and for short periods. Such locations correspond to Zone 2 classification to IEC 60079-0.
  - The type of protection is “Ex nA IIC T4 Gc” according to IEC 60079-15.
  - Comply to Standards IEC 60079-0:6th Edition, IEC 60079-15:4th Edition>, reference IECEx certificate number <IECEx UL 15.0055X.>.
-

## Module Overview

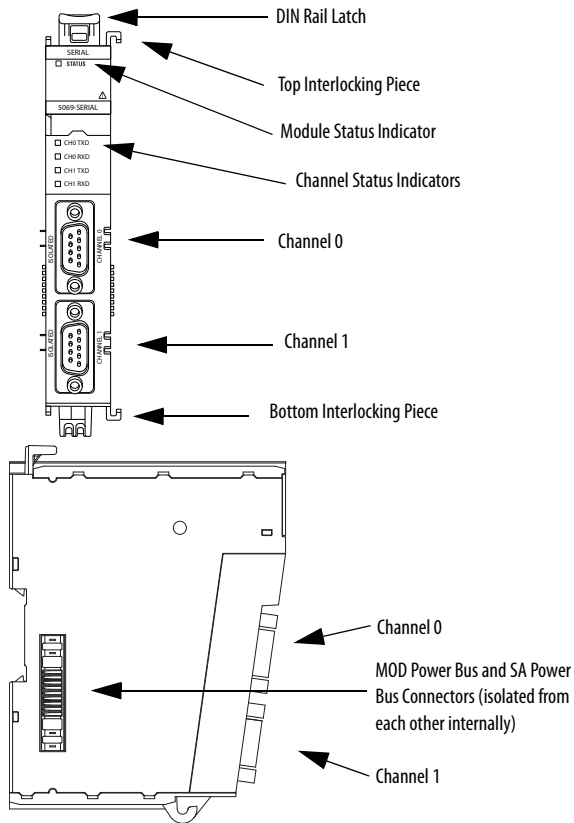

## Required Components

To install the module, you need these physical components.

Component	Description
End cap	An end cap ships with the Compact GuardLogix 5380 controllers and the Compact 5000 I/O EtherNet/IP adapter.
Tools	<ul style="list-style-type: none"> <li>Screwdriver</li> <li>9-Pin Serial Cable</li> </ul>

## Dimensions

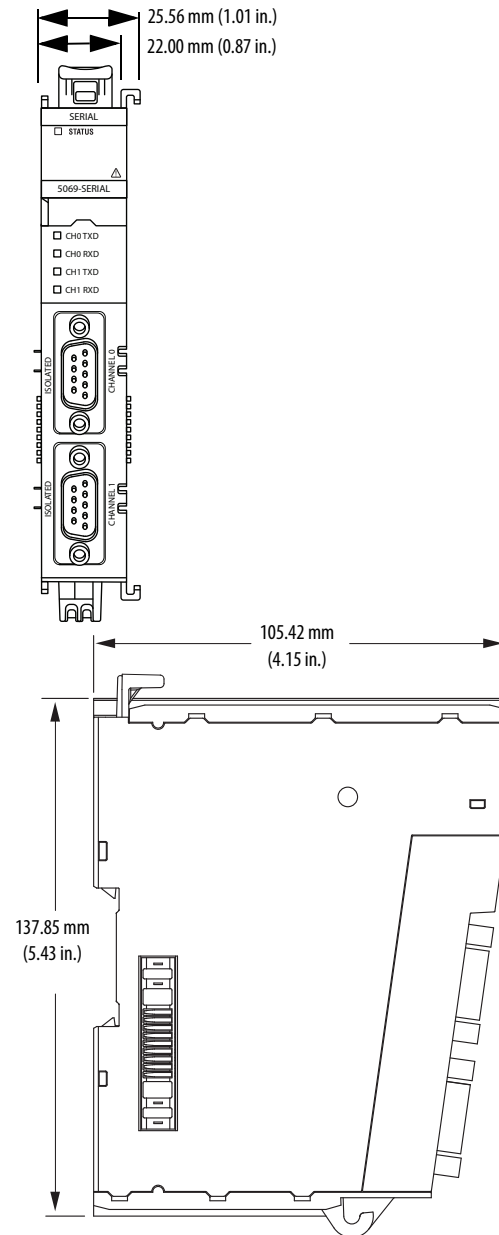

## Install a System

Before you install the module, you must install one of the following:

- CompactLogix 5380 or Compact GuardLogix 5380 controller when the module is a local Compact 5000 I/O module.
- Compact 5000 I/O EtherNet/IP adapter when the module is a remote Compact 5000 I/O module.

For more information on how to install these components, see [Additional Resources on page 11](#).

## Ground Considerations

You must ground DIN rails according to the Industrial Automation Wiring and Grounding Guidelines, publication [1770-4.1](#).



**ATTENTION:** This product is grounded through the DIN rail to chassis ground. Use zinc-plated yellow chromate-passivated steel DIN rail to ensure proper grounding. The use of other DIN rail materials (for example, aluminum or plastic) that can corrode, oxidize, or are poor conductors, can result in improper or intermittent grounding. Secure DIN rail to mounting surface approximately every 200 mm (7.8 in.) and use end-anchors appropriately. Be sure to ground the DIN rail properly. See Industrial Automation Wiring and Grounding Guidelines, Rockwell Automation publication [1770-4.1](#) for more information

You can use the EN50022 - 35 x 7.5 mm (1.38 x 0.30 in.) DIN rails with a Compact 5000 I/O module.

## System Power Considerations

The following components provide system power based on the system in which you are installing the module:

- CompactLogix 5380 or Compact GuardLogix 5380 controller when the module is a local Compact 5000 I/O module.
- Compact 5000 I/O EtherNet/IP adapter when the module is a remote Compact 5000 I/O module.

The following power types are available:

- **Module (MOD) power** - System-side power that is required to operate the Compact 5000 I/O system. MOD power is provided through the MOD power RTB and passed across the MOD power bus.
- **Sensor/Actuator (SA) power** - Field-side power that is used to power field-side devices. SA power is provided through the SA power RTB and passed across the SA power bus.

A 5069-FPD field potential distributor can also provide SA power to a Compact 5000 I/O system.

You must use SELV/PELV listed power supplies for MOD and SA power if 5069-SERIAL will connect to Compact GuardLogix 5380 controller and all other Functional Safety I/O modules.

### IMPORTANT

We recommend that you use separate external power supplies for MOD power and SA power respectively. This practice can help prevent unintended consequences that can result if you use one supply.

If you use separate external power supplies, the loss of power from one external power supply does not affect the availability of power from the other supply. For example, if separate external power supplies are used and SA power is lost, MOD power remains available for the 5069 Compact I/O modules.

For more information on MOD power and SA power, see the following:

- CompactLogix 5380 and Compact GuardLogix 5380 Controllers User Manual, publication [5069-UM001](#)
- EtherNet/IP Communication Modules in Logix 5000™ Control Systems User Manual, publication [ENET-UM004](#)
- Compact 5000 I/O Serial Module User Manual, publication [5069-UM003](#)
- Compact 5000 I/O and 5069 Compact Guard I/O™ Safety Modules Specifications Technical Data, publication [5069-TD001](#)

## Install the Module



**WARNING:** If you insert or remove the module while backplane power is on, an electric arc can occur. This arc could cause an explosion in hazardous location installations.

The module does not support "Removal and Insertion Under Power" (RIUP) capability. Do not connect or disconnect the module while power is applied. Be sure that power is removed before proceeding.

Based on your system configuration, install the I/O module next to one of the following:

- CompactLogix 5380 or Compact GuardLogix 5380 controller,
- Compact 5000 I/O EtherNet/IP adapter
- Compact 5000 I/O module

To install the module, complete these steps.

1. Confirm that MOD power and all sources of SA power are off. If you remove the module with power applied, the system MOD power bus and SA power bus are affected. For example, you can interrupt MOD power to the other modules in the system. Unintended consequences can occur as a result.
2. If an end cap is installed on the right-most module that is installed in the system, remove it and keep for later use.
 

**ATTENTION:** Do not discard the end cap. Use this end cap to cover the exposed interconnections on the last module on the DIN rail. Failure to do so could result in equipment damage or injury from electric shock.
3. Confirm that the DIN rail latch is closed.
4. If the DIN rail latches are open, gently push the rear latch back until the front latch pops up and clicks.

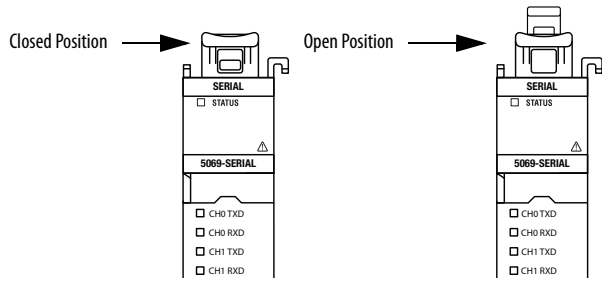

- Align the interlocking pieces of the module with the device on the left.

The top interlocking pieces engage first.

- Push the module toward the DIN rail until a click indicates that the module is locked in place.

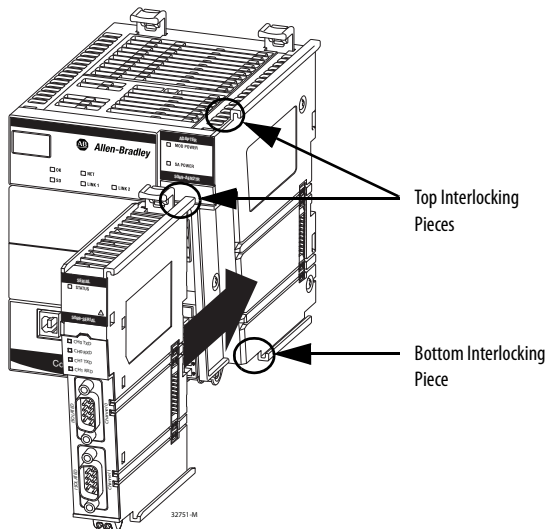

- Verify that the module is installed in one of the following ways:
  - If the module is installed on a Compact GuardLogix 5380 controller or Compact 5000 I/O EtherNet/IP adapter, the front of the Compact 5000 I/O module is set back slightly from the front of the controller or adapter, respectively.
  - If the module is installed on a Compact 5000 I/O module, the fronts of both modules are flush with each other.

## Install the End Cap

You must install an end cap on the last module in your system.

- Align the end cap with the interlocking pieces on the module.
- Push the end cap toward the DIN rail until it locks in place.

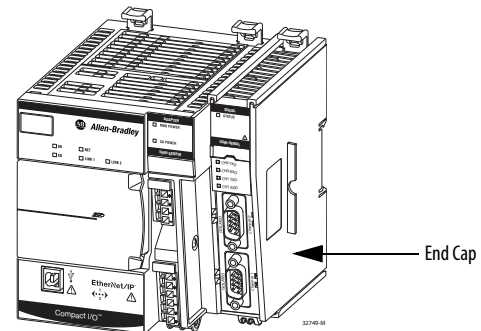
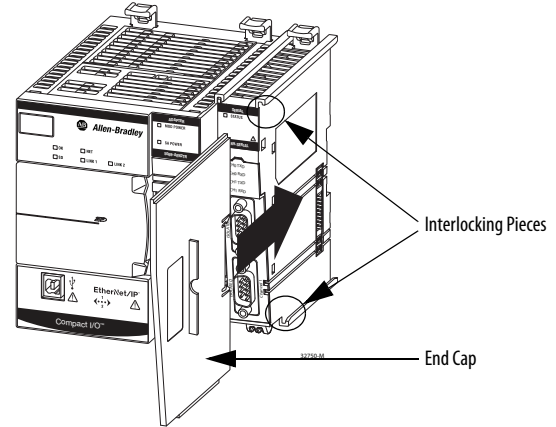

## Connect the Serial Cable



**WARNING:** For equipment with single-point (RS232C/422/etc) serial communication connections, include the following:

- If you connect or disconnect the serial cable with power applied to this module or the serial device on the other end of the cable, an electric arc can occur. This arc could cause an explosion in hazardous location installations.
- Be sure that power is removed or the area is nonhazardous before proceeding.

If you are connecting to both channels on the serial module, we recommend connecting to channel 1 first.

- Confirm that MOD power and all sources of SA power are turned off.

2. Connect the serial cable to the desired channel.

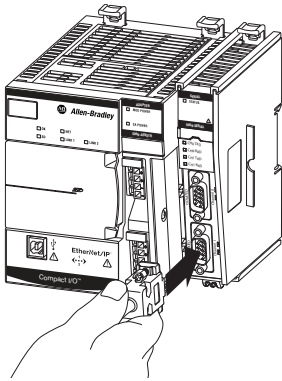

3. Tighten the screws on both sides of the serial cable.

5. Pull the module off the DIN rail.

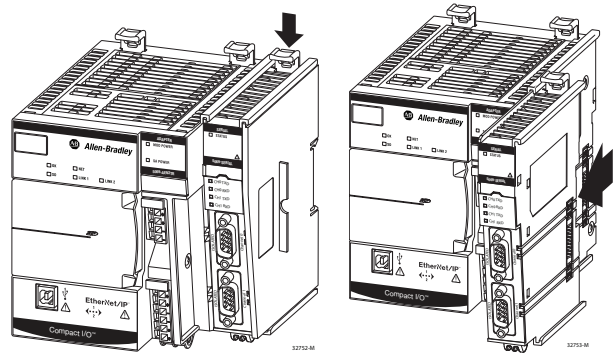

6. To replace the module, follow the steps that are described beginning at [Install the Module on page 6](#).

## Power the System

After you install all Compact 5000 I/O modules, you can turn on MOD power and, if used, SA power.

For more information, see [System Power Considerations on page 6](#).

## Remove the Module

1. Confirm that MOD power and all sources of SA power are turned off.

**IMPORTANT** Before you remove power from the MOD power RTB and, if used, SA power RTB, consider the effect on your system.

When you remove MOD power and SA power from a CompactLogix 5380 controller, Compact GuardLogix 5380 controller, or a Compact 5000 I/O EtherNet/IP adapter, you shut down power to all Compact 5000 I/O modules. That is, all system-side and field-side power is removed.

We strongly recommend that you take the appropriate actions to help prevent unintended consequences that can result from a system power shutdown before removing MOD power and SA power.

2. If necessary, remove the end cap from the right side of the module.
3. If desired, complete the following steps to disconnect the serial cable from the module:
  - a. Loosen the screws on both sides of the serial cable.
  - b. Pull the serial cable out of the module.
4. Press the DIN rail latch down until it clicks and let go of the latch.

## Communication Port Pins

The following image shows the pin layout for the serial module. Tables 1...3 reflect the media that you use.

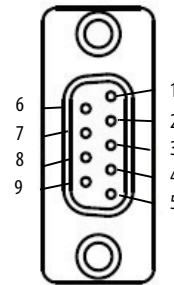

**Table 1 - Pin RS-232C**

Pin	RS-232C	Input (i)/ Output (o) <sup>(1)</sup>	Wiring	
			No Handshaking	Handshaking
1	Data Carrier Detect (DCD)	(i)	-(2)	-
2	Receive Data (RXD)	(i)	A <sup>(3)</sup>	A
3	Transmit Data (TXD)	(o)	A	A
4	Data Terminal Ready (DTR)	(o)	B <sup>(4)</sup>	B
5	Common (COM)	-	A	A
6	Data Set Ready (DSR)	(i)	-	-
7	Request To Send (RTS)	(o)	B	A
8	Clear To Send (CTS)	(i)	-	A
9	-	-	-	-

(1) From 5069-SERIAL

(2) Not used

(3) A = Changing signal level (Active/Inactive)

(4) B = Fixing signal level (Active/Inactive)



**Table 2 - Pin RS-422**

Pin	RS-422	Input (i)/Output (o) <sup>(2)</sup>	Wiring
1	_ <sup>(1)</sup>	-	-
2	Receive Data + (RXD+)	(i)	A <sup>(3)</sup>
3	Transmit Data + (TXD+)	(o)	A
4	-	-	-
5	Common (COM)	-	A
6	-	-	-
7	Transmit Data - (TXD-)	(o)	A
8	Receive Data - (RXD-)	(i)	A
9	-	-	-

(1) Not used

(2) From 5069-SERIAL

(3) A = Changing signal level (Active/Inactive)

**Table 3 - Pin - RS-485**

Pin	RS-485	Input (i)/Output (o) <sup>(2)</sup>	Wiring
1	_ <sup>(1)</sup>	-	-
2	-	-	-
3	Transmit/Receive Data + (TRXD+)	(i/o)	A <sup>(3)</sup>
4	-	-	-
5	Common (COM)	-	A
6	-	-	-
7	Transmit/Receive Data - (TRXD-)	(i/o)	A
8	-	-	-
9	-	-	-

(1) Not used

(2) From 5069-SERIAL

(3) A = Changing signal level (Active/Inactive)

## Wire the Module

Wire the module based on the media you plan to connect to it.

### RS-232

The RS-232 can be wired in multiple ways as shown in the following images.

**IMPORTANT** If you wire the module incorrectly, the control between wiring and output signal can fail.

#### 5069-SERIAL to DTE Device without Hardware Handshaking

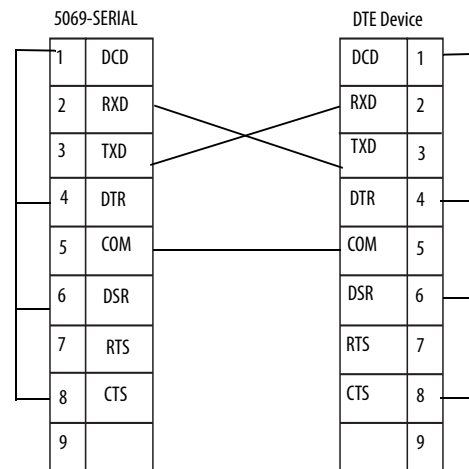

#### 5069-SERIAL to DTE Device with "Half-duplex"

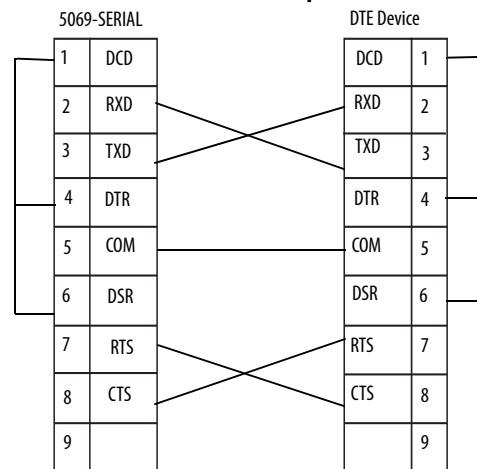

**5069-SERIAL to DCE Device with “Full-duplex”**

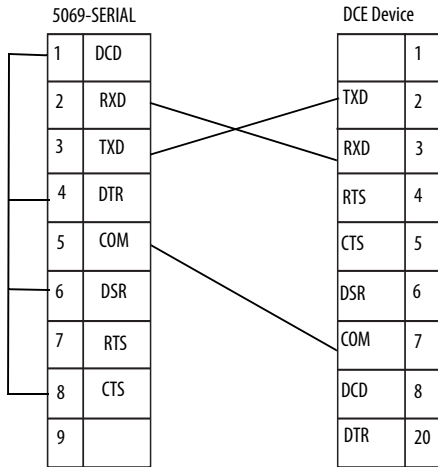

**5069-SERIAL to DCE Device (Modem) with “Full or Half-duplex”**

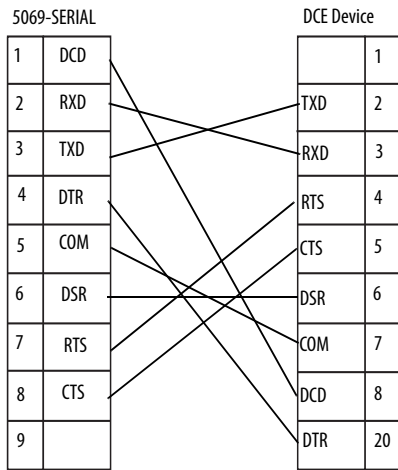

**5069-SERIAL to DTE Device with “Full or Half-duplex” or Null Modem**

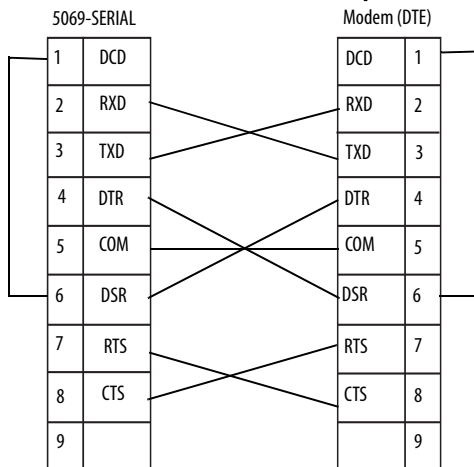

**RS-422**

**5069-SERIAL RS-422 Wiring**

**IMPORTANT** Place the termination resistor between RxD+ and RxD- to implement this wiring.

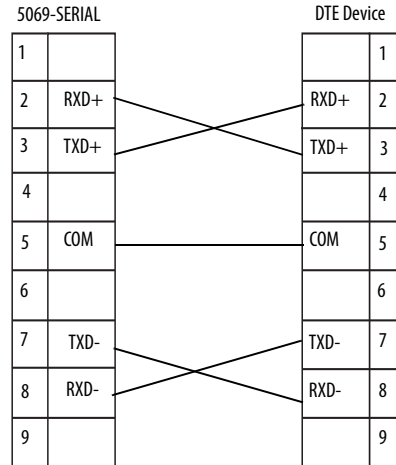

**RS-485**

**5069-SERIAL RS-485 Wiring**

**IMPORTANT** Place the termination resistor between TRXD+ and TRXD- to implement this wiring.

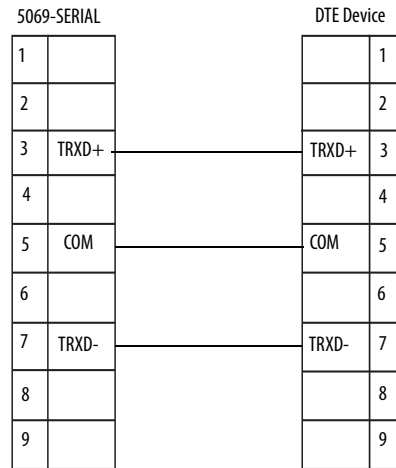

## Specifications

The following table lists a subset of the module specifications. For a complete list of specifications, see the Compact 5000 I/O Modules Specifications Technical Data, publication [5069-TD001](#).

Attribute	Value
Temperature, operating IEC 60068-2-1 (Test Ad, Operating Cold) IEC 60068-2-2 (Test Bd, Operating Dry Heat) IEC 60068-2-14 (Test Nb, Operating Thermal Shock)	0 °C < Ta < 60 °C (32 °F < Ta < 140 °F)
Temperature, surrounding, air, max.	60 °C (140 °F)
Enclosure type rating	None (open-style)
Voltage and current ratings	
MOD Power	100 mA, 18...32V DC
Mod Power Passthrough <sup>(1)</sup>	9.55A, 18...32V DC
SA Power Passthrough <sup>(2)</sup>	9.95A, 0...32V DC
Do not exceed 10A MOD or SA Power (Passthrough) current draw	
Isolation voltage	250V (continuous), Basic Insulation Type, SA and MOD Power to Backplane 250V (continuous), Basic Insulation Type, Backplane to Communication Channels 250V (continuous), Basic Insulation Type, Backplane to Chassis Ground 250V (continuous), Basic Insulation Type, Between Communication Channels 250V (continuous), Basic Insulation Type, SA to MOD Power 250V (continuous), Basic Insulation Type, Communication Channels to Chassis Ground 250V (continuous), Basic Insulation Type, SA and MOD Power to Chassis Ground  250V (continuous), Reinforced Insulation Type, SA and MOD Power to Communication Channels  Basic Insulation Type tested at 2100V DC for 60 s Reinforced Insulation Type tested at 4200V DC for 60 s
North American temp code	T4
ATEX temp code	T4
IECEx temp code	T4

- (1) Level of MOD Power current that passes through the module depends on the system configuration, such as, module slot location and the other module types that are used in the system. For more information, see the Compact 5000 I/O Modules and EtherNet/IP Adapters Technical Data, [5069-TD001](#), CompactLogix 5380 and Compact GuardLogix 5380 Controllers User Manual, [5069-UM001](#), and EtherNet/IP Communication Modules in Logix 5000 Control Systems User Manual, [ENET-UM004](#).
- (2) Level of SA Power current that passes through the module depends on the system configuration, such as, module slot location and the other module types that are used in the system. For more information, see the Compact 5000 I/O Modules and EtherNet/IP Adapters Technical Data, [5069-TD001](#), CompactLogix 5380 and Compact GuardLogix 5380 Controllers User Manual, [5069-UM001](#), and EtherNet/IP Communication Modules in Logix 5000 Control Systems User Manual, [ENET-UM004](#).

## Additional Resources

These documents contain additional information concerning related products from Rockwell Automation.

Resource	Description
CompactLogix 5380 and Compact GuardLogix 5380 Controllers User Manual, publication <a href="#">5069-UM001</a>	Explains how to use the CompactLogix 5380 and Compact GuardLogix controllers.
EtherNet/IP Communication Modules in Logix 5000 Control Systems User Manual, publication <a href="#">ENET-UM004</a>	Describes how to use EtherNet/IP communication modules in Logix 5000 control systems.
Compact 5000 I/O Serial Interface Module User Manual, publication <a href="#">5069-UM003</a>	Describes how to use a Compact 5000 I/O serial module in a Logix 5000 control system.
Compact 5000 I/O Modules and EtherNet/IP Adapters Specifications Technical Data, publication <a href="#">5069-TD001</a>	Provides specifications and wiring diagrams for Compact 5000 I/O modules and EtherNet/IP adapters.
Industrial Automation Wiring and Grounding Guidelines, publication <a href="#">1770-4.1</a>	Provides general guidelines for installing a Rockwell Automation industrial system.
Product Certifications website, <a href="http://www.rockwellautomation.com/global/certification/overview.page">http://www.rockwellautomation.com/global/certification/overview.page</a>	Provides declarations of conformity, certificates, and other certification details.

You can view or download publications at <http://www.rockwellautomation.com/global/literature-library/overview.page>. To order paper copies of technical documentation, contact your local Allen-Bradley distributor or Rockwell Automation sales representative.

**Notes:**

**Notes:**

**Notes:**

**Notes:**

## Rockwell Automation Support

Use the following resources to access support information.

<b>Technical Support Center</b>	Knowledgebase Articles, How-to Videos, FAQs, Chat, User Forums, and Product Notification Updates.	<a href="https://rockwellautomation.custhelp.com/">https://rockwellautomation.custhelp.com/</a>
<b>Local Technical Support Phone Numbers</b>	Locate the phone number for your country.	<a href="http://www.rockwellautomation.com/global/support/get-support-now.page">http://www.rockwellautomation.com/global/support/get-support-now.page</a>
<b>Direct Dial Codes</b>	Find the Direct Dial Code for your product. Use the code to route your call directly to a technical support engineer.	<a href="http://www.rockwellautomation.com/global/support/direct-dial.page">http://www.rockwellautomation.com/global/support/direct-dial.page</a>
<b>Literature Library</b>	Installation Instructions, Manuals, Brochures, and Technical Data.	<a href="http://www.rockwellautomation.com/global/literature-library/overview.page">http://www.rockwellautomation.com/global/literature-library/overview.page</a>
<b>Product Compatibility and Download Center (PCDC)</b>	Get help determining how products interact, check features and capabilities, and find associated firmware.	<a href="http://www.rockwellautomation.com/global/support/pcdc.page">http://www.rockwellautomation.com/global/support/pcdc.page</a>

## Documentation Feedback

Your comments will help us serve your documentation needs better. If you have any suggestions on how to improve this document, complete the How Are We Doing? form at [http://literature.rockwellautomation.com/idc/groups/literature/documents/du/ra-du002\\_-en-e.pdf](http://literature.rockwellautomation.com/idc/groups/literature/documents/du/ra-du002_-en-e.pdf).

Rockwell Automation maintains current product environmental information on its website at <http://www.rockwellautomation.com/rockwellautomation/about-us/sustainability-ethics/product-environmental-compliance.page>.

Allen-Bradley, Compact I/O, CompactLogix, GuardLogix, Logix5000, Rockwell Automation, Rockwell Software, and Studio 5000 Logix Designer are trademarks of Rockwell Automation, Inc. Trademarks not belonging to Rockwell Automation are property of their respective companies.

Rockwell Otomasyon Ticaret A.Ş., Kar Plaza İş Merkezi E Blok Kat:6 34752 İçerenköy, İstanbul, Tel: +90 (216) 5698400

**[www.rockwellautomation.com](http://www.rockwellautomation.com)**

### Power, Control and Information Solutions Headquarters

Americas: Rockwell Automation, 1201 South Second Street, Milwaukee, WI 53204-2496 USA, Tel: (1) 414.382.2000, Fax: (1) 414.382.4444

Europe/Middle East/Africa: Rockwell Automation NV, Pegasus Park, De Kleetlaan 12a, 1831 Diegem, Belgium, Tel: (32) 2 663 0600, Fax: (32) 2 663 0640

Asia Pacific: Rockwell Automation, Level 14, Core F, Cyberport 3, 100 Cyberport Road, Hong Kong, Tel: (852) 2887 4788, Fax: (852) 2508 1846