

Hiperface-to-DSL Feedback Converter Kit

Catalog Number 2198-H2DCK

Summary of Changes

- Removed drive information (not specific to this kit) and added emphasis on the drive user manuals, listed in [Additional Resources](#), for making feedback connections.
- Added steps to enhance [Install the Converter Kit](#) on [page 2](#).

About the Feedback Converter Kit

This kit is designed for use with Allen-Bradley® 2090-Series motor feedback cables and provides wire terminations for 10 Hiperface encoder signals. The Hiperface encoder signals are converted into compatible digital-servo-link (DSL) feedback signals. You must wire the 10-pin converter kit connector and assemble the connector housing with the cable shield and cable jacket properly positioned.

Prepare the Cables

To prepare your existing Bulletin 2090 cables for use with the feedback converter kit, some preparation is necessary so that the cable shield, conductor lengths, and strip lengths are correct. Make sure your feedback cable preparation follows these guidelines:

- Trim the shield flush so that no strands can cause a short to adjacent terminals.
- Measure the conductor lengths so they are long enough to provide a service loop.
- Remove just enough insulation from each conductor to provide the proper strip length.

Feedback Cable

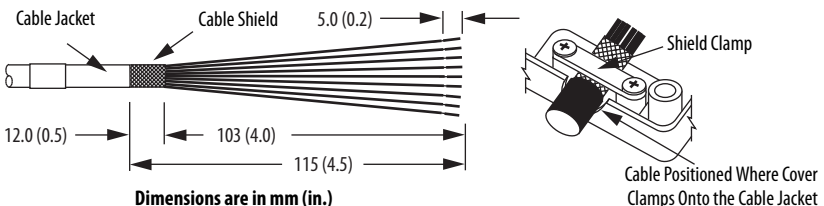

Install the Converter Kit

Follow these steps to install the converter kit.

1. Remove the cover and route signal wires to the proper terminals leaving service loops for each connection.
See [Connector Data](#) on [page 3](#) for the 10-pin terminal pinout.
2. Tighten terminal screws to achieve 0.25 N•m (2.2 lb•in), maximum torque.
3. Apply the shield clamp to the 12 mm (0.5 in.) of exposed cable shield to achieve a high-frequency bond between the shield braid and clamp.

IMPORTANT The purpose of the shield clamp is to provide a proper ground and improve system performance. To achieve this, clamping the exposed braid under the shield clamp is critical.

4. Attach the tie wrap (supplied with the kit) for stress relief.
5. Tighten clamp screws to achieve 0.3 N•m (2.6 lb•in) maximum torque.

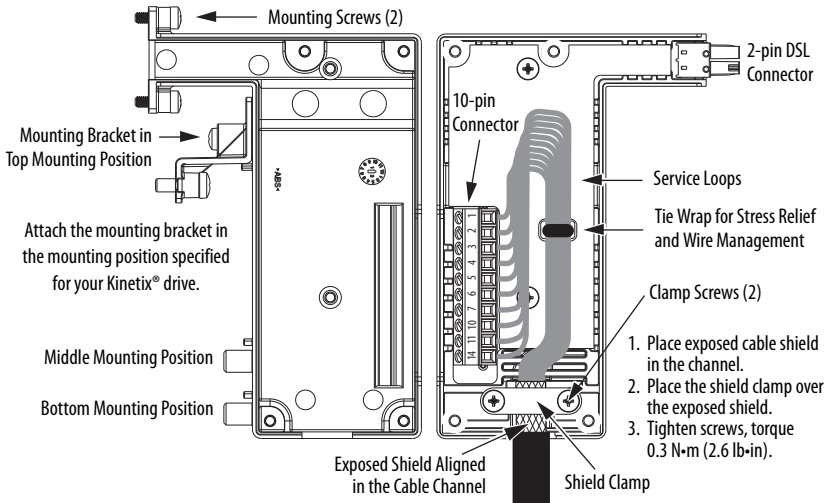

6. Replace the cover and install cover screws.
Tighten cover screws to achieve 0.3 N•m (2.6 lb•in) maximum torque.
7. Insert the two-pin DSL connector into the drive connector and attach the mounting bracket in one of three mounting positions.
 - Mounting position depends on the drive family.
 - Mounting-hole protective cover on the drive depends on the drive family.
 See [Additional Resources](#) on [page 4](#) for access to the user manual for your servo drive.
8. Tighten mounting screws to achieve 0.4 N•m (3.5 lb•in) maximum torque.

Connector Data

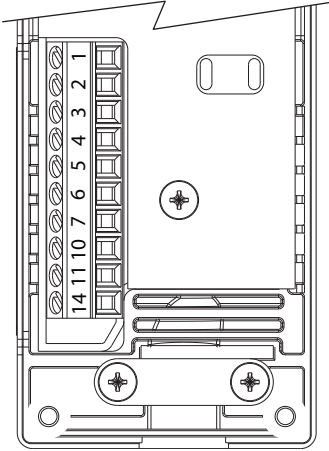

Converter Kit Pinout

Pin	Signal	Wire Color
1	SIN+	Black
2	SIN-	White/Black
3	COS+	Red
4	COS-	White/Red
5	DATA+	Green
6	ECOM ⁽¹⁾	White/Gray
7	EPWR_9V ⁽²⁾	Orange
10	DATA-	White/Green
11	TS	White/Orange
14	EPWR_5V ⁽²⁾	Gray

- (1) The ECOM and TS- connections are tied together and connect to the cable shield.
- (2) The converter kit generates 5V and 9V from a 12V supply coming from the drive. The 5V supply is used by 5V encoders in 230V motors. The 9V supply is used by 9V encoders in 460V motors.

Converter Kit Specifications

Attribute	Value
Cable diameter	6.5...11.9 mm (0.26...0.47 in.)
Screw terminal wire size	0.08...1.5 mm ² (28...16 AWG)
Recommended feedback wire strip length	5 mm (0.2 in.) single conductor
Recommended torque Mounting screws Terminal screws Clamp and cover screws	0.4 N·m (3.5 lb-in) 0.22...0.25 N·m (1.9...2.2 lb-in) 0.3 N·m (2.6 lb-in)
Kit contents	<ul style="list-style-type: none"> • Converter kit, mounting and cover screws • Shield clamp, screws • Mounting bracket, captive screws • Clamp spacer (Kinetix 5500 drives) • Tie wrap • Spare screws (2)

Clamp Spacer Installation

A clamp spacer is included with the 2198-H2DCK feedback converter kit for power cable diameters that are too small for a tight fit within the Kinetix 5500 drive clamp alone.

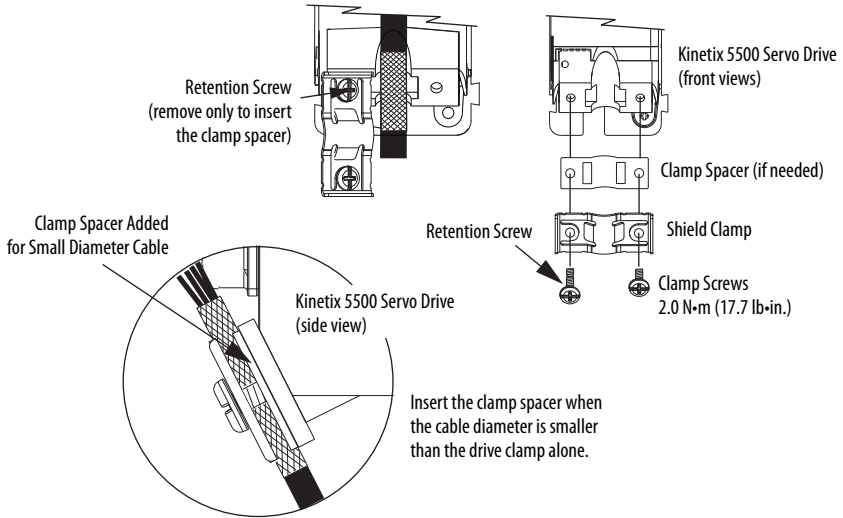

IMPORTANT In addition to this publication, we strongly recommend that you refer to your drive user manual for additional information about making feedback connections to the drive.

Additional Resources

These documents contain additional information concerning related products from Rockwell Automation.

Resource	Description
Kinetix 5700 Servo Drives User Manual, publication 2198-UM002	Provides information to install, configure, start, and troubleshoot your Kinetix servo drive system. Also includes drive-specific installation and grounding techniques for the 2198-H2DCK feedback converter kit.
Kinetix 5500 Servo Drives User Manual, publication 2198-UM001	

You can view or download publications at <http://www.rockwellautomation.com/literature>.

Rockwell Automation maintains current product environmental information on its website at <http://www.rockwellautomation.com/rockwellautomation/about-us/sustainability-ethics/product-environmental-compliance.page>.

Allen-Bradley, Kinetix, Rockwell Automation, and Rockwell Software are trademarks of Rockwell Automation, Inc. Trademarks not belonging to Rockwell Automation are property of their respective companies.

Rockwell Otomasyon Ticaret A.Ş., Kar Plaza İş Merkezi E Blok Kat:6 34752 İçerenköy, İstanbul, Tel: +90 (216) 5698400
www.rockwellautomation.com

Power, Control and Information Solutions Headquarters

Americas: Rockwell Automation, 1201 South Second Street, Milwaukee, WI 53204-2496 USA, Tel: (1) 414.382.2000, Fax: (1) 414.382.4444
 Europe/Middle East/Africa: Rockwell Automation NV, Pegasus Park, De Kleetlaan 12a, 1831 Diegem, Belgium, Tel: (32) 2 663 0600, Fax: (32) 2 663 0640
 Asia Pacific: Rockwell Automation, Level 14, Core F, Cyberport 3, 100 Cyberport Road, Hong Kong, Tel: (852) 2887 4788, Fax: (852) 2508 1846

Publication 2198-IN006C-EN-P - May 2017

8016732

Supersedes Publication 2198-IN006B-EN-P - November 2014

Copyright © 2017 Rockwell Automation, Inc. All rights reserved. Printed in the U.S.A.