

Operating instructions
 Instruções de operação
 Notice d'utilisation
 Istruzioni d'uso
 Betriebsanleitung
 Instrucciones de operación
 Инструкции по эксплуатации
 操作说明
 取扱説明書
 사용자 매뉴얼

Contactors
 Contatores
 Contacteurs
 Contattori
 Schütze
 Contactores
 Контакторы
 接触器
 コンタクタ
 컨택터

Auxiliary contacts
 Contatos auxiliares
 Contacts auxiliaires
 Contatto ausiliari
 Hilfsschalter
 Contactos auxiliares
 Вспомогательные контакты
 補助触点
 補助接点
 보조 접점



IEC/EN 60947-4-1
 UL 60947-4-1
 CAN/CSA-C22.2 No. 60947-4-1
 GB/T 14048.4

Attention! Risk of electrical shock. Disconnect power before servicing, commissioning, decommissioning, and dismantling. Installation and commissioning of this product must be carried out by a qualified electrician, following installation standards and safety regulations. Before installing the contactor, make sure that the control voltage supply corresponds with the marked control voltage. High voltage testing shall not be carried out across the control terminals (A1 and A2). Applying the wrong control voltage or high voltage across the terminals can damage the contactor's electronic control circuits. Do not touch live parts.

Atenção! Risco de choque elétrico. Desconecte a alimentação antes de fazer manutenção, comissionamento, desativação e desmontagem. A instalação e comissionamento deste produto devem ser efetuados por um electricista qualificado, de acordo com as normas de instalação e de segurança. Antes de instalar o contator, certifique-se de que a alimentação de tensão de controle corresponda à tensão de controle marcada. Os testes de alta tensão não devem ser realizados através dos terminais de controle (A1 e A2). Aplicar a tensão de controle ou alta tensão erradas, através dos terminais, pode danificar os circuitos de controle eletrônico do contator. Não toque nas peças sob tensão.

Attention! Risque de choc électrique. Débrancher l'alimentation électrique avant toute intervention, mise en service ou mise hors service et démantèlement. L'installation et la mise en service de ce produit doivent être réalisées par un électricien qualifié, en respectant les normes d'installation et les réglementations relatives à la sécurité. Avant l'installation du contacteur, vérifier que la tension de commande fournie correspond à la tension de commande indiquée. Des tests de tension élevée ne doivent pas être réalisés sur les bornes de commande (A1 et A2). L'application d'une tension erronée ou d'une tension élevée sur les bornes peut endommager les circuits électroniques du contacteur. Ne pas toucher les pièces sous tension.

Attenzione! Rischio di scossa elettrica. Interrompere l'alimentazione prima di ogni operazione di manutenzione, messa in servizio, dismissione e smontaggio. Le operazioni di installazione e messa in servizio di questo prodotto devono essere effettuate da un elettricista qualificato, nel rispetto degli standard di installazione e delle norme di sicurezza. Prima dell'installazione del contattore, verificare che la tensione di controllo fornita dall'alimentazione corrisponda a quella indicata. Non eseguire i test ad alta tensione sui morsetti di controllo (A1 e A2). L'applicazione di alta tensione o di una tensione di controllo non corretta ai morsetti può danneggiare i circuiti elettronici di controllo del contattore. Non toccare le parti in tensione.

Achtung! Stromschlaggefahr. Unterbrechen Sie vor Wartungsarbeiten, Inbetriebnahme, Außerbetriebnahme und Demontage die Stromversorgung. Die Installation und Inbetriebnahme dieses Produkts darf nur durch einen Elektrofachmann gemäß den Installationsstandards und Sicherheitsvorschriften durchgeführt werden. Stellen Sie vor der Installation des Schützes sicher, dass die Steuerungspannungsversorgung der angegebenen Steuerungspannung entspricht. An den Steuerklemmen (A1 und A2) dürfen keine Hochspannungstests durchgeführt werden. Beim Anlegen der falschen Steuerungspannung oder beim Anlegen von Hochspannung an den Klemmen können die elektronischen Steuerstromkreise des Schützes beschädigt werden. Berühren Sie niemals stromführende Teile.

¡Atención! Riesgo de descarga eléctrica. Desconecte la alimentación eléctrica antes de dar servicio, poner en marcha, retirar de servicio y desmontar. La instalación y la puesta en marcha de este producto se deben llevar a cabo por un electricista cualificado de acuerdo con las normas de instalación y regulaciones de seguridad. Antes de instalar el contactor, asegúrese de que la alimentación de tensión de control corresponda a la tensión de control indicada. No se deben realizar pruebas de alta tensión de los terminales de control (A1 y A2). La aplicación de tensión de control incorrecta o alta tensión incorrecta a los terminales puede dañar los circuitos de control electrónicos del contactor. No toque partes activas.

Внимание! Опасность поражения электрическим током. Отключите питание перед выполнением обслуживания, ввода в эксплуатацию, вывода из эксплуатации и демонтажа. Монтаж и ввод данного изделия в эксплуатацию должен выполняться квалифицированным электриком в соответствии со стандартами электрического монтажа и правилами техники безопасности. Перед установкой контактора убедитесь в том, что подаваемое управляющее напряжение соответствует управляемому напряжению, указанному на паспортной табличке. Запрещается проводить высоковольтные испытания через клеммы управления (A1 и A2). Приложение некорректного управляющего напряжения или высокого напряжения к клеммам может повредить электронные цепи управления контактора. Не прикасайтесь к деталям, находящимся под напряжением.

注意! 电击危险。请在维修、调试、撤拆和拆解前断开电源。本产品的安装和调试必须由具有资质的电工根据安装标准和安全法规来执行。安装接触器前，确保控制电源电压与标识的控制电压一致。控制端子之间（A1 和 A2）不得执行高压测试。在此类端子间施加错误的控制电压或高压会损坏接触器的电子控制电路。不得触碰带电部件。

注意! 感電の危険。処置、立上げ、廃棄、解体を行なう前には、電源を必ず切断してください。本製品の取付け、立上げは設置基準および安全規制に従って、資格のある電気技術者によって実施する必要があります。コンタクタの取付け前に、制御電圧電源が規定された制御電圧に対応していることを必ず確認してください。高電圧試験を、制御端子(A1およびA2)の間で実施してはなりません。端子間に誤った制御電圧や高電圧を印加すると、コンタクタの電子制御回路が損傷することがあります。帯電部には触れないでください。

주의! 감전 위험. 작동, 시운전, 해체 및 철거 전에 전원을 분리하십시오. 이 제품의 설치 및 시운전은 설치 표준 및 안전 규정에 따라 자격을 갖춘 전기기사만 수행할 수 있습니다. 컨택터를 설치하기 전에 제어 전압 공급이 표시된 제어 전압과 일치하는지 확인하십시오. 고전압 테스트는 제어 단자(A1 및 A2) 전체에 걸쳐 수행하면 안 됩니다. 단자 전체에 걸쳐 잘못된 제어 전압이나 고전압을 적용하면 컨택터의 전자 제어 회로가 손상될 수 있습니다. 전기가 흐르는 부품에 만지지 마십시오.

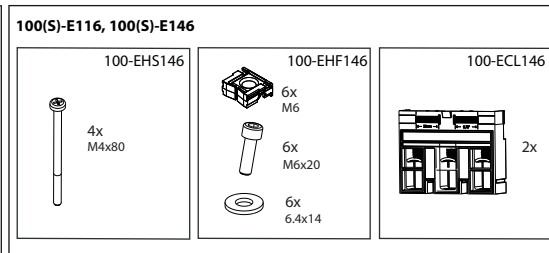
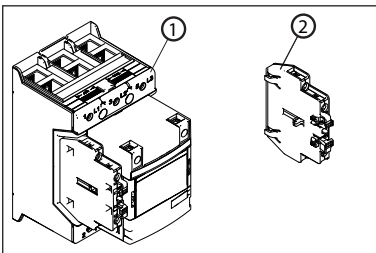
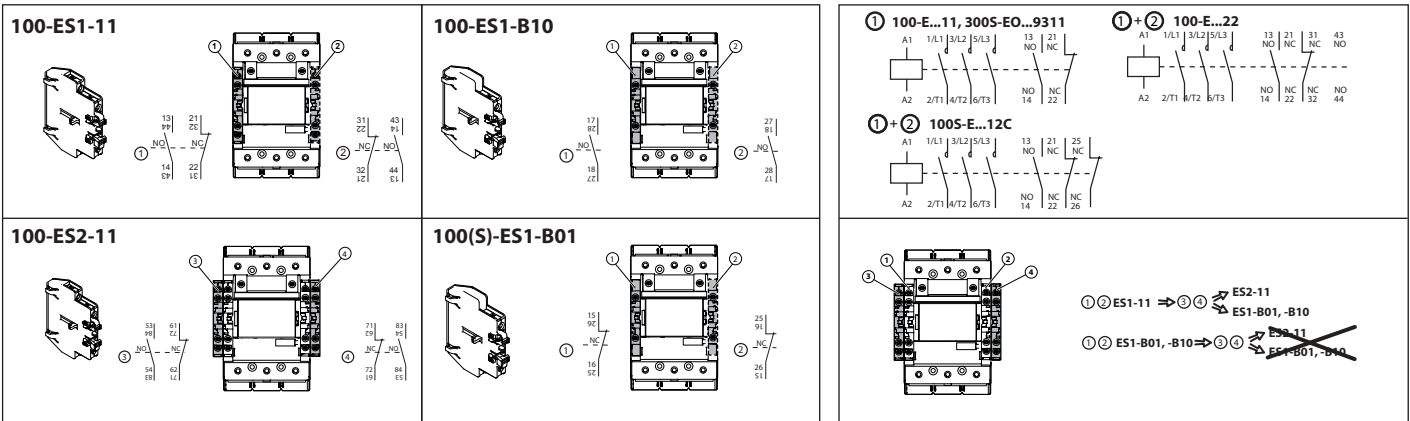

100-ES1-11 Pilot duty acc. to UL 60947-4-1

| Rating code | Thermal Continuous Current | Voltage | Make/Break Current |
|-------------|----------------------------|--------------------|--------------------------|
| A 600 | 10A | 120V AC | 60A / 6A |
| | | 240V AC | 30A / 3A |
| | | 480V AC 600V AC | 15A / 1.5A 12A / 1.2A |
| Q 300 | 2.5A | 125V DC 250V DC | 0.55 A 0.27 A |

General

100(S)-E and 300(S)-EO contactors are fitted with an electronic interface. For a given coil, this allows the contactor to accept a very wide voltage range.

Code KJ, KD, KN (J, Y, D, B)

Operation is done, as with conventional contactors, by applying and removing supply voltage on A1 and A2. Closing 85% and opening at 55% of the lower nominal voltage limit, which is indicated in the functional diagram.

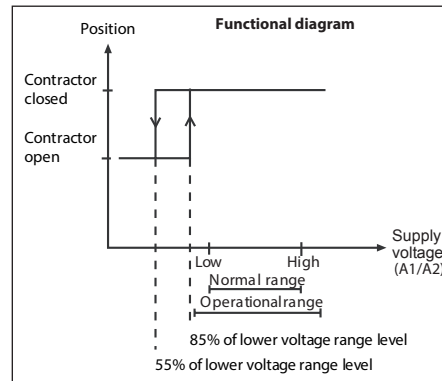

Code ED and EN built-in PLC interface

Operation is controlled by separate logic control signals from, for instance, a PLC. Use of logic control requires a steady supply voltage on A1 and A2 within the rated voltage range, as described for code KJ, KY, KD and KN (J, Y, D, B). The function of the logic control signal will no longer be guaranteed when the supply voltage on A1 and A2 is removed.

The logic control signals are operated with 24V DC. There are two control signals (ON and OFF_N) and a common reference (COM). For the control signals, the function is guaranteed from 15V DC (6mA) to 33V DC (20mA).

The contactor is closed by a control signal ON and opened by removal of control signal from OFF_N. The functions are described in diagram below. "1" means 24V DC between the control signal and COM. "0" means no voltage between the control signal and COM. Minimum control signal pulse length for opening and closing is 10ms. To connect the PLC interface, use cable dimension of max 1.5mm².

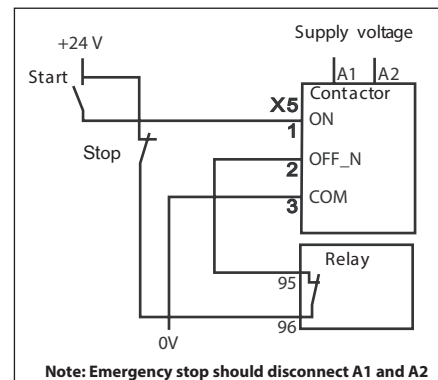

When used with switches the wiring can be done according to diagram above

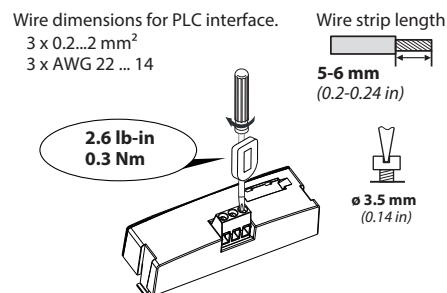
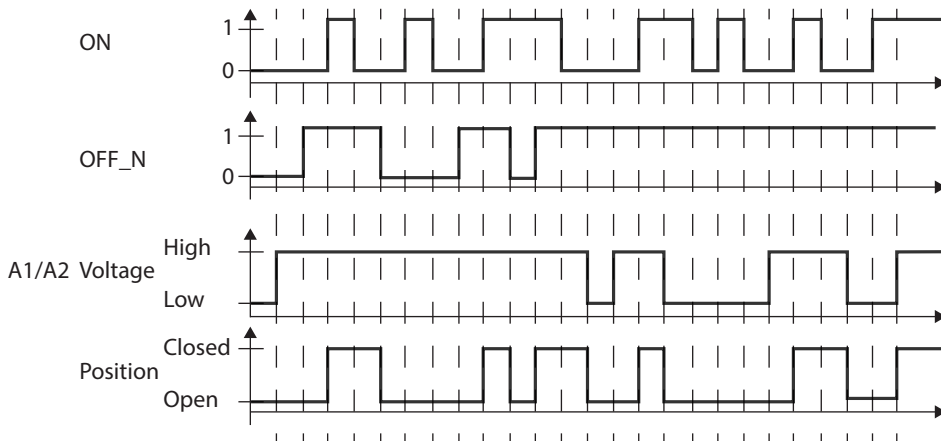
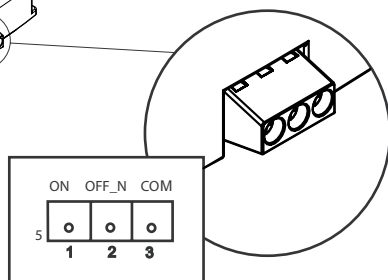
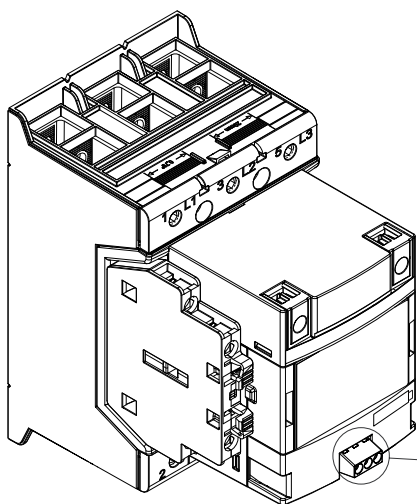

| | |
|--------------------|--|
| Notice! | This product has been designed for environment A. Use of this product in environment B may cause unwanted electromagnetic disturbances in which case, the user may be required to take adequate mitigation measures. |
| Aviso! | Este produto foi projetado para o ambiente A. O uso deste produto em ambiente B pode causar perturbações eletromagnéticas indesejadas, cujo caso o usuário poderá ser obrigado a tomar medidas de mitigação adequadas. |
| Attention! | Ce produit est conçu pour un environnement A. L'utilisation de ce produit dans un environnement B peut provoquer des perturbations électromagnétiques indésirables, auquel cas l'utilisateur devra peut-être prendre des mesures d'atténuation appropriées. |
| Avviso! | Questo prodotto è stato concepito per essere utilizzato in ambiente A. L'utilizzo di questo prodotto in ambiente B può comportare la generazione di interferenze elettromagnetiche indesiderate per cui l'utente dovrebbe adottare le necessarie contromisure. |
| Hinweis! | Dieses Produkt ist für Umgebung A ausgelegt. Die Verwendung dieses Produkts in Umgebung B kann zu unerwünschten elektromagnetischen Störungen führen. In diesem Fall muss der Benutzer entsprechende Gegenmaßnahmen ergreifen. |
| ¡Aviso! | Este producto ha sido diseñado para el ambiente A. El uso de este producto en el ambiente B puede provocar perturbaciones electromagnéticas no deseadas. En tal caso el usuario puede tener que tomar medidas de mitigación apropiadas. |
| Примечание! | Данный продукт был разработан для среды класса А. Использование этого продукта в среде класса В может вызвать нежелательные электромагнитные помехи. В этом случае от пользователя может потребоваться принятие адекватных мер по их предотвращению. |
| 注意! | 本产品设计用于环境 A。在环境 B 中使用本产品可能会导致有害的电磁干扰，用户在这种情况下需要采取充分的缓解措施。 |
| 通知! | 本製品は環境A向けに設計されました。環境Bで本製品を使用すると、望ましくない電磁波による障害を引き起こす可能性があります。その場合、ユーザは十分な緩和措置をとる必要があります。 |
| 참고! | 이 제품은 환경 A에 맞게 설계되었습니다. 이 제품을 환경 B에서 사용하면 전자파 장애가 발생해 사용자가 적절한 완화 조치를 취해야 할 수 있습니다. |

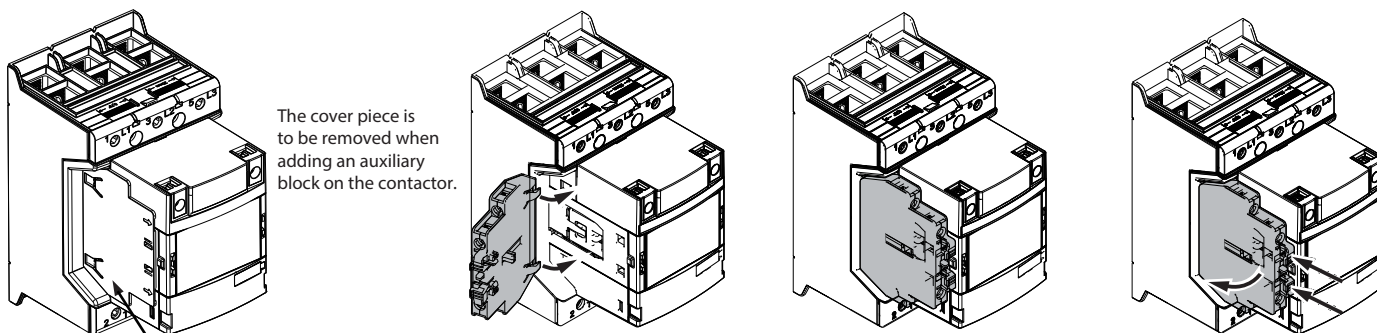

The cover piece is to be removed when adding an auxiliary block on the contactor.

Cover piece

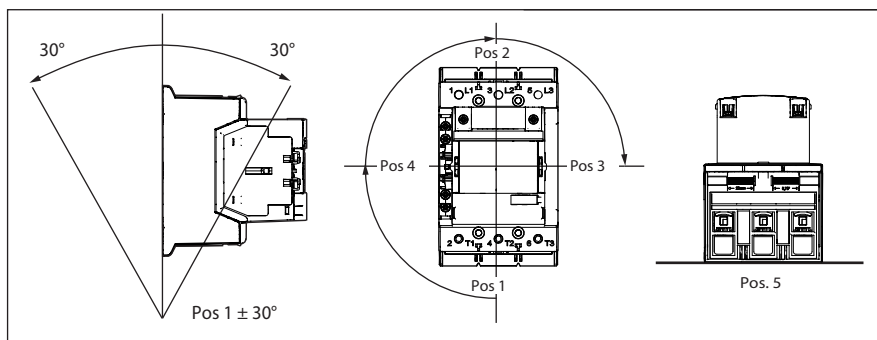

30 mm
(1.18 in)

4x M4

> 5 mm
(0.20 in)

100 mm
(3.94 in)

Pz 2

13 lb-in
1.5 Nm

i Only use wires of the same dimension when you connect 2 wires to each terminal.

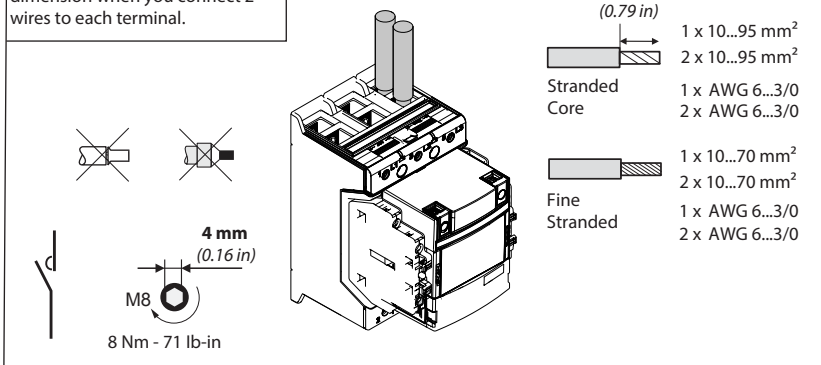

5 mm
(0.20 in)

M6

9 Nm - 80 lb-in

20 mm
(0.79 in)

5.5 mm
(0.22 in)

22 mm
(0.86 in)

| | | | | | | | | | |
|------------------------|-----------------------|------|--|--|--|--|--|--|-------------------|
| | | | | | | | | | |
| M3.5 1 Nm - 9 lb-in | Ø 5.5 mm (0.22 in) | Pz 2 | 1 x 1...4 mm ² 2 x 1...4 mm ² 1 x AWG 18...14 2 x AWG 18...14 | 1 x 0.75...2.5 mm ² 2 x 0.75...2.5 mm ² 1 x AWG 18...14 2 x AWG 18...14 | 1 x 0.75...2.5 mm ² 2 x 0.75...2.5 mm ² 1 x AWG 18...14 2 x AWG 18...14 | 1 x 0.75...2.5 mm ² 2 x 0.75...2.5 mm ² 1 x AWG 18...14 2 x AWG 18...14 | 1 x 0.75...2.5 mm ² 2 x 0.75...2.5 mm ² 1 x AWG 18...14 2 x AWG 18...14 | 1 x 0.75...2.5 mm ² 2 x 0.75...2.5 mm ² 1 x AWG 18...14 2 x AWG 18...14 | 9 mm (0.35 in) |

According to UL 60947-4-1 Use wire Cu 75°C only. Use built-in cable clamps or UL recognized compression lugs. Enclosure with min. dimension 24 by 20 by 10 inches should be used. Suitable for use on a circuit capable of delivering not more than the max symmetrical amperes at the max voltage shown in the table below.

Type 1

100(S)-E116, 100(S)-E146, 300(S)-EO

| | | | | | | |
|--|---------|-------|---------|---------|---------|---------|
| Circuit Breaker A | 140G-J | | 140G-J2 | 140G-J3 | 140G-J6 | 140G-J0 |
| Fuse A/Class | 250/RK5 | 250/J | | | | |
| Max Short Circuit Current at 208-240V (kA) | 5 | 100 | 65 | 100 | 100 | 100 |
| Max Short Circuit Current at 480V (kA) | 10 | 100 | 25 | 35 | 65 | 100 |
| Max Short Circuit Current at 600V (kA) | 10 | 100 | 18 | 22 | 25 | 50 |

Type 2

100(S)-E116, 100(S)-E146, 300(S)-EO

| | | | |
|--|--------|-------|---------|
| Circuit Breaker A | 140G-J | | 140G-J6 |
| Fuse A/Class | 200/J | 200/J | |
| Max Short Circuit Current at 480V (kA) | 10 | 100 | 65 |
| Max Short Circuit Current at 600V (kA) | 10 | 100 | 25 |

UL/CSA definite purpose magnetic motor controller. Breaking all lines.
Max 600V AC, 50/60 Hz:

| TYPE | Herm. ref. comp, AC-8a | | Ballast, AC-5a/ Resistance air heating | Elevator duty |
|-------------|------------------------|------|---|---------------|
| | FLA | LRA | | |
| 100(S)-E116 | 116 | 800 | 160 | 54 |
| 100(S)-E146 | 160 | 1050 | 200 | 54 |
| 300(S)-EO | 160 | 1050 | 200 | 54 |

For applications above 690V, terminal shrouds 100-ETS146L should be used.

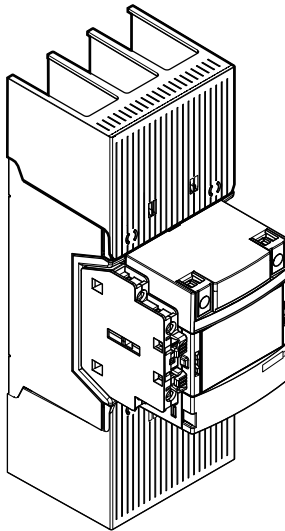

Rockwell Automation maintains current product environmental information on its website at <http://www.rockwellautomation.com/rockwellautomation/about-us/sustainability-ethics/product-environmental-compliance.page>.

Allen-Bradley, Rockwell Software, and Rockwell Automation are trademarks of Rockwell Automation, Inc. Trademarks not belonging to Rockwell Automation are property of their respective companies.

www.rockwellautomation.com

 Allen-Bradley • Rockwell Software

**Rockwell
Automation**

Power, Control and Information Solutions Headquarters

Americas: Rockwell Automation, 1201 South Second Street, Milwaukee, WI 53204-2496 USA, Tel: (1) 414.382.2000, Fax: (1) 414.382.4444

Europe/Middle East/Africa: Rockwell Automation NV, Pegasus Park, De Kleedlaan 12a, 1831 Diegem, Belgium, Tel: (32) 2 663 0600, Fax: (32) 2 663 0640

Asia Pacific: Rockwell Automation, Level 14, Core F, Cyberport 3, 100 Cyberport Road, Hong Kong, Tel: (852) 2887 4788, Fax: (852) 2508 1846

Publication 100-IN022B-EN-E October, 2017

DIR 10002941731 (Version 02)

Copyright © 2017 Rockwell Automation, Inc. All Rights Reserved. Printed in Sweden.