

# Rittal – The System.

Faster – better – everywhere.

► World's first – The  principle

New output class  
1600 W



ENCLOSURES

POWER DISTRIBUTION

CLIMATE CONTROL

IT INFRASTRUCTURE

SOFTWARE & SERVICES



FRIEDHELM LOH GROUP

# Rittal – The System.

Faster – better – everywhere.



ENCLOSURES

POWER DISTRIBUTION

CLIMATE CONTROL

FRIEDHELM LOH GROUP

# The whole is more than the sum of its parts

The same is true of “Rittal – The System.” With this in mind, we have bundled our innovative enclosure, power distribution, climate control and IT infrastructure products together into a single system platform. Complemented by our extensive range of software tools and global service, we create unique added value for trade and industry: Production plant, test equipment, facility management and data centres. In accordance with our simple principle, “Faster – better – everywhere”, we are able to combine innovative products and efficient service to optimum effect.

**Faster** – with our “Rittal – The System.” range of modular solutions, which guarantees fast planning, assembly, conversion and commissioning with its system compatibility.

**Better** – by being quick to translate market trends into products. In this way, our innovative strength helps you to secure competitive advantages.

**Everywhere** – thanks to global networking:

- 13 production facilities with almost 250,000 m<sup>2</sup> production space worldwide
- 58 subsidiaries
- Around 90 warehouse facilities with more than 180,000 pallet locations and over 250,000 m<sup>2</sup> storage space worldwide

IT INFRASTRUCTURE

SOFTWARE & SERVICES



# Rittal – The System.

Faster – better – everywhere.

# World's first

The Blue e+ cooling unit series – the ultimate in efficiency.  
Worldwide.

## The principle:

- **Efficiency** – Average 75% energy savings thanks to speed-regulated components and heat pipe technology
- **Versatility** – Suitable for international use due to unique multi-voltage capability
- **Safety** – Longer service life of the components inside the enclosure and the cooling unit due to component-friendly cooling
- **User-friendliness** – Intuitive operation due to touch display and intelligent interfaces

ENCLOSURES

POWER DISTRIBUTION

CLIMATE CONTROL



IT INFRASTRUCTURE

SOFTWARE & SERVICES





Rittal climate control/Wall-mounted cooling units Blue e+

The **e+** principle

# Revolutionary energy efficiency with innovative hybrid technology

## Unbelievably efficient

- Let hybrid technology take your cooling units' energy efficiency to a whole new level
- Active cooling circuit with speed-regulated components for demand-based cooling
- Integral heat pipe for passive cooling dissipates heat from the enclosure as soon as the ambient temperature falls below the setpoint

## Transparent efficiency comparisons

- Energy Efficiency Ratio:  
The standardised efficiency ratio
- Seasonal Energy Efficiency Ratio:  
The seasonal efficiency ratio for actual energy consumption

## Amazingly economical

- Average 75% energy savings
- Component-friendly cooling for a longer service life
- A constant temperature inside the enclosure is ensured – with three control modes
- High operational reliability

## Easier to calculate

- Determine your energy savings with the efficiency calculator
- TCO calculation includes all costs arising in the product's lifecycle
- Precise amortisation calculation

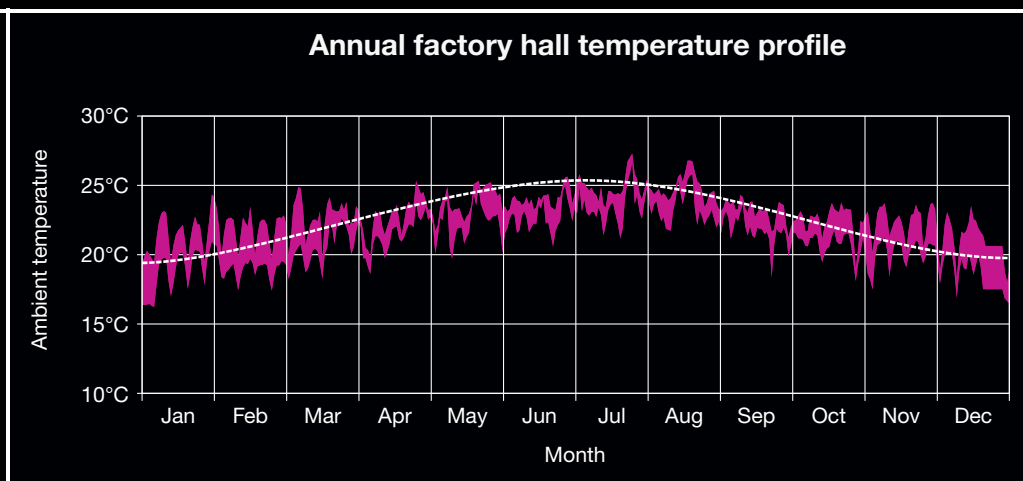

Rittal specifies the SEER to indicate the actual efficiency of a cooling unit, since a precise calculation must also consider the seasonal temperature variation. The standard point for determining the EER does not make allowance for actual fluctuations in hall temperatures.





The **e+** principle

# Simple operation with touch display and intelligent interfaces

## Get information faster

- Fast device analysis with RiDiag software via the USB interface
- Remote monitoring via Ethernet in conjunction with the IoT interface

## Blue e+ app

- Contactless information exchange and rapid, direct on-site analysis via an NFC interface
- Simple repair, maintenance and spare parts enquiries may be sent directly via your smart-phone
- Save device data directly on the device

## Easier to operate

- Fast parameterisation, data reading and plain-text system messages on the intelligent, multi-lingual, industrial-grade display

## IoT interface

- For linking Blue e+ cooling units and Blue e+ chillers to the customer's own monitoring, energy management and/or superordinate systems
- Analysis and parametrisation
- Device data can be supplied in most standard protocols
- Generate your own dashboards and analyses
- Attaches to the top hat rail or to the cooling unit itself

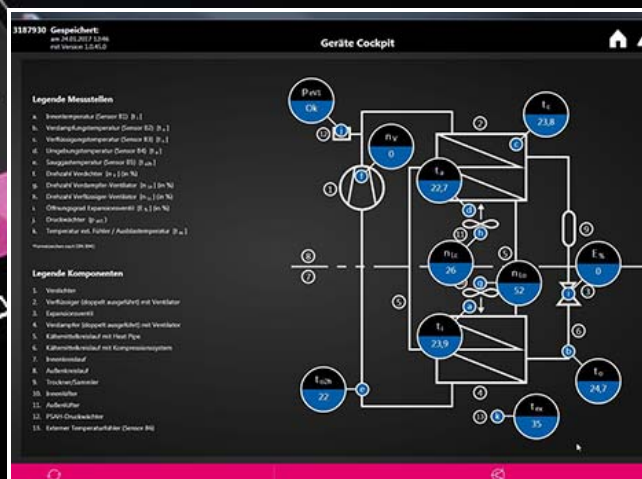



The **e+** principle

# Versatility through standard assembly

## Easy assembly

- One version for external mounting, partial internal mounting and full internal mounting
- One mounting cut-out for external mounting, partial internal mounting and full internal mounting in multiple output categories
- Maintenance-friendly, tool-free filter mat replacement

## Fast assembly

- Handle for convenient transport and positioning
- Mounting clip as securing aid
- Eyebolts for easy mounting

## Maximum flexibility with unique multi-voltage capability

- One unit for all voltages and networks, suitable for worldwide use thanks to inverter technology:
  - 110 – 240 V, 1~, 50 – 60 Hz
  - 380 – 480 V, 3~, 50 – 60 Hz

## International approvals and certifications

- cULus Listed
- EAC
- TÜV Nord GS
- TÜV Nord-tested output measurement
- cULus FTTA



# Wall-mounted cooling units Blue e+



Accessories for climate control Page 14 Therm software Cat. 35, page 474 RiDiag software Page 15

## Benefits:

- Average 75% energy savings thanks to speed-regulated components and heat pipe technology
- Suitable for international use due to a unique multi-voltage capability
- Longer service life of the components inside the enclosure and the cooling unit due to component-friendly cooling
- Intuitive operation due to touch display and intelligent interfaces

## Temperature control:

- e+ controller (factory setting +35°C)

## Material:

- Sheet steel

## Colour:

- RAL 7035

## Protection category IP to IEC 60529:

- Internal circuit IP 55

## Supply includes:

- Assembly parts
- Fully wired ready for connection (plug-in terminal strip)

## Note:

- Please observe the mounting instructions.

## Approvals:

Available on the Internet

## Performance diagrams:

Available on the Internet

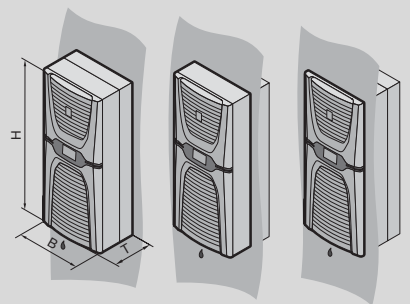

## Output class 1600 W

| Model No.  | Packs of | 3185.830                                     | Page         |
|--|----------|--|--------------|
| <b>Total cooling output 50 Hz L35 L35 to DIN EN 14511 kW</b>                                     |          | <b>1.6</b>                                   |              |
| Total cooling output 50/60 Hz L35 L35 kW   |          | 1.6 / 1.6                                    |              |
| Total cooling output 50/60 Hz L35 L50 kW   |          | 1.2 / 1.2                                    |              |
| Rated operating voltage V, ~, Hz   |          | 110 - 240, 1~, 50/60<br>380 - 480, 3~, 50/60 |              |
| Width (B) mm   |          | 400  |              |
| Height (H) mm  |          | 950  |              |
| Depth (T) mm   |          | 310  |              |
| Rated output kW  |          | 0.62   |              |
| Power consumption P <sub>el</sub> 50/60 Hz L35 L35 kW  |          | 0.54 / 0.54                                  |              |
| Power consumption P <sub>el</sub> 50/60 Hz L35 L50 kW  |          | 0.61 / 0.61                                  |              |
| Operating temperature range  |          | -20°C...+60°C                                |              |
| Setting range  |          | +20°C...+50°C                                |              |
| Storage temperature range  |          | -40°C...+70°C                                |              |
| Energy efficiency ratio (EER) 50 Hz L35 L35 to DIN EN 14511                                      |          | 3.05   |              |
| Seasonal energy efficiency ratio (SEER) 50/60 Hz L35 L35   |          | 6.4  |              |
| Refrigerant g  |          | R134a, 750                                   |              |
| Permissible operating pressure (p. max.) bar   |          | 24   |              |
| Air throughput of fans (unimpeded air flow), internal circuit/external circuit m <sup>3</sup> /h |          | 700 / 895                                    |              |
| Weight kg  |          | 30.5   |              |
| <b>Accessories</b>   |          |  |              |
| Filter mats  | 3 pc(s). | 3285.800                                     | 14           |
| Metal filters  | 1 pc(s). | 3285.810                                     | 14           |
| Temperature sensor   | 1 pc(s). | 3124.400                                     | 14           |
| Door-operated switch   | 1 pc(s). | 4127.010                                     | Cat. 35, 755 |

# Wall-mounted cooling units Blue e+



Accessories for climate control Page 14 Therm software Cat. 35, page 474 RiDiag software Page 15

## Benefits:

- Average 75% energy savings thanks to speed-regulated components and heat pipe technology
- Suitable for international use due to a unique multi-voltage capability
- Longer service life of the components inside the enclosure and the cooling unit due to component-friendly cooling
- Intuitive operation due to touch display and intelligent interfaces

## Temperature control:

- e+ controller (factory setting +35°C)

## Material:

- Sheet steel

## Colour:

- RAL 7035

## Protection category IP to IEC 60529:

- Internal circuit IP 55

## Supply includes:

- Assembly parts
- Fully wired ready for connection (plug-in terminal strip)

## Note:

- Please observe the mounting instructions.

## Approvals:

Available on the Internet

## Performance diagrams:

Available on the Internet

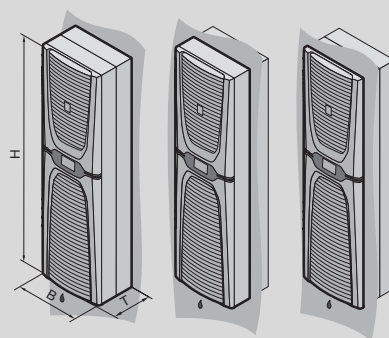

## Output class 2000 – 6000 W

| Model No.  | Packs of | 3186.930                                     | 3187.930                                     | 3188.940                       | 3189.940                       | Page |
|--|----------|--|--|--------------------------------|--------------------------------|------|
| <b>Total cooling output 50 Hz L35 L35 to DIN EN 14511 kW</b>                                     |          | <b>2</b>                                     | <b>2.6</b>                                   | <b>4.2</b>                     | <b>5.8</b>                     |      |
| Total cooling output 50/60 Hz L35 L35 kW   |          | 2 / 2  | 2.6 / 2.6                                    | 4.2 / 4.2                      | 5.8 / 5.8                      |      |
| Total cooling output 50/60 Hz L35 L50 kW   |          | 1.29 / 1.29                                  | 1.82 / 1.82                                  | 3.02 / 3.02                    | 4.2 / 4.2                      |      |
| Rated operating voltage V, ~, Hz   |          | 110 - 240, 1~, 50/60<br>380 - 480, 3~, 50/60 | 110 - 240, 1~, 50/60<br>380 - 480, 3~, 50/60 | 380 - 480, 3~, 50/60           | 380 - 480, 3~, 50/60           |      |
| Width (B) mm   |          | 450  | 450  | 450                            | 450                            |      |
| Height (H) mm  |          | 1600   | 1600   | 1600                           | 1600                           |      |
| Depth (T) mm   |          | 294  | 294  | 393                            | 393                            |      |
| Rated output kW  |          | 0.73   | 1.05   | 1.3                            | 2.2                            |      |
| Power consumption P <sub>el</sub> 50/60 Hz L35 L35 kW  |          | 0.57 / 0.57                                  | 0.99 / 0.99                                  | 1.21 / 1.21                    | 2.2 / 2.2                      |      |
| Power consumption P <sub>el</sub> 50/60 Hz L35 L50 kW  |          | 0.6 / 0.6                                    | 0.94 / 0.94                                  | 1.28 / 1.28                    | 2.2 / 2.2                      |      |
| Operating temperature range  |          | -20°C...+60°C                                | -20°C...+60°C                                | -20°C...+60°C                  | -20°C...+60°C                  |      |
| Setting range  |          | +20°C...+50°C                                | +20°C...+50°C                                | +20°C...+50°C                  | +20°C...+50°C                  |      |
| Storage temperature range  |          | -40°C...+70°C                                | -40°C...+70°C                                | -40°C...+70°C                  | -40°C...+70°C                  |      |
| Energy efficiency ratio (EER) 50 Hz L35 L35 to DIN EN 14511                                      |          | 3.5  | 2.63   | 3.46                           | 2.64                           |      |
| Seasonal energy efficiency ratio (SEER) 50/60 Hz L35 L35   |          | 8.1  | 6.2  | 8.1                            | 6.2                            |      |
| Refrigerant g  |          | R134a, 1150                                  | R134a, 1150                                  | R134a, 1750                    | R134a, 1750                    |      |
| Air throughput of fans (unimpeded air flow), internal circuit/external circuit m <sup>3</sup> /h |          | 1250 / 1250                                  | 1250 / 1250                                  | 2300 / 2300                    | 2300 / 2300                    |      |
| Weight kg  |          | 55.2   | 55.2   | 72.4                           | 72.4                           |      |
| Note on Model No.  |          | -  | -  | Full installation not possible | Full installation not possible |      |

## Accessories

|                      |          |          |          |          |          |                 |
|----------------------|----------|----------|----------|----------|----------|-----------------|
| Filter mats          | 3 pc(s). | 3285.900 | 3285.900 | 3285.900 | 3285.900 | 14              |
| Metal filters        | 1 pc(s). | 3285.910 | 3285.910 | 3285.910 | 3285.910 | 14              |
| Temperature sensor   | 1 pc(s). | 3124.400 | 3124.400 | 3124.400 | 3124.400 | 14              |
| Door-operated switch | 1 pc(s). | 4127.010 | 4127.010 | 4127.010 | 4127.010 | Cat. 35,<br>755 |

# Accessories for climate control



## Filter mats

### for cooling units, air/air heat exchangers and chillers

Rittal cooling units are low-maintenance and are supplied without filter mats. Filter mats may be used for extreme conditions.

#### Benefits:

- Temperature-resistant from -40°C...+80°C

#### Material:

- Open-celled polyurethane foamed plastic

| To fit Model No.                                     | for cooling units | for chillers | W x H x D mm   | Packs of | Model No.       |
|--|-------------------|--------------|----------------|----------|-----------------|
| 3185.830   | ■                 | –            | 360 x 297 x 10 | 3 pc(s). | <b>3285.800</b> |
| 3186.930/3187.930/<br>3188.940/3189.940/<br>3334.400 | ■                 | ■            | 380 x 358 x 10 | 3 pc(s). | <b>3285.900</b> |



## Metal filters

Particularly when cooling units are used in dusty and oily environments, it is advisable to use washable metal filters. If air or steam condenses on the metal surfaces, any particles present will adhere to the metal, and can easily be washed out with water or grease-dissolving detergents.

#### Material:

- Aluminium

| To fit Model No.                                     | for cooling units | for chillers | W x H x D mm   | Packs of | Model No.       |
|--|-------------------|--------------|----------------|----------|-----------------|
| 3185.830   | ■                 | –            | 320 x 280 x 10 | 1 pc(s). | <b>3285.810</b> |
| 3186.930/3187.930/<br>3188.940/3189.940/<br>3334.400 | ■                 | ■            | 380 x 358 x 10 | 1 pc(s). | <b>3285.910</b> |



## Temperature sensor

### for Blue e+ cooling units, Blue e+ chillers

NTC sensor to regulate Blue e+ cooling units according to an individual measurement point within the enclosure (control based on an external sensor), and according to the cold air outlet from the cooling unit inside the enclosure (control based on outlet temperature). For chillers: Differential control is used if it is necessary to regulate the temperature of the medium depending on the ambient temperature (positive or negative). For this, the temperature sensor needs to be positioned near the Blue e+ chiller.

#### Supply includes:

- External sensor with connection cable (length 2.5 m)

| Packs of | Model No.       |
|----------|-----------------|
| 1 pc(s). | <b>3124.400</b> |

# Accessories for climate control

## RiDiag

Software for the parameterisation, diagnosis and analysis of Rittal cooling units.

|                                  |   |
|----------------------------------|---|
| For                              | Blue e+ chillers<br>Blue e+ cooling units   |
| Design                           | RiDiag III  |
| Product-specific scope of supply | Full, downloadable version in German and English.<br>Release of additional functions with chargeable licence under Model No. 3159.300 |
| Packs of                         | 1 pc(s).  |
| <b>Model No.</b>                 | <b>3159.300</b>   |

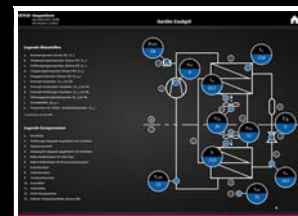

## IoT interface

The IoT interface is used to link Rittal components such as Blue e+ cooling units, Blue e+ chillers, smart monitoring systems etc. to the customer's own monitoring and/or energy management systems. Data may be integrated both horizontally and vertically into data collectors and processors, to allow the long-term logging and evaluation of device data, statuses and system messages.

### Communication protocols:

SNMPv1, SNMPv2c, SNMPv3, OPC-UA, Modbus/TCP, CAN bus, Profinet

### Network protocols:

Telnet, SSH, FTP, SFTP, HTTP, HTTPS, NTP, DHCP, DNS, SMTP, Syslog, LDAP, RADIUS

### Benefits:

- The IoT interface is middleware, whose interfaces allow a variety of devices and systems to communicate with one another. The data can then be forwarded into superordinate systems.

### Material:

- Plastic to UL 94-V0

### Colour:

- RAL 7016 Anthracite grey

### Protection category IP to IEC 60529:

- IP 20

### Supply includes:

- Connection cable (1 m) with RJ 45 connector
- Angle bracket for Blue e+ cooling unit



### Assembly instruction:

- The IoT interface can be secured on a 35 x 7.5 top hat rail to DIN EN 60 715 using a spring-loaded metal clip, or to the rear of a Blue e+ cooling unit using the angle bracket.



|                               |   |
|-------------------------------|---|
| W x H x D mm                  | 18 x 117 x 120  |
| For                           | Blue e+ cooling units<br>Blue e+ chillers<br>Smart monitoring system<br>CMC III sensors   |
| Operating temperature range   | +0°C...+70°C  |
| Protocols                     | SNMP<br>OPC-UA<br>Modbus/TCP<br>CAN bus<br>Profinet   |
| Interfaces                    | 1 x Micro USB type B (device) for USB 2.0<br>1 x Micro-SD memory card slot for SD 2.0<br>1 x USB 2.0 high-speed functions (EHCI)<br>1 x acknowledgement button<br>1 x 3-pole push-in spring connection terminal for NTC sensor<br>2 x RJ45 jack for RS 485 interface (climate control unit interface) |
| Network interface             | Ethernet IPv4/IPv6<br>Ethernet to IEEE 802.3 via 10BASE-T, 100BASE-T and 1000BASE-T   |
| Type of electrical connection | 3-pole push-in spring connection terminal (24 V DC)   |
| Packs of                      | 1 pc(s).  |
| <b>Model No.</b>              | <b>3124.300</b>   |

# Wall-mounted cooling units Blue e+

## Technical details

### Wall-mounted cooling units

Blue e+ SK 3186.930, SK 3187.930, SK 3188.940, SK 3189.940

Installation options SK 3186.930, SK 3187.930

Installation options SK 3188.940, SK 3189.940

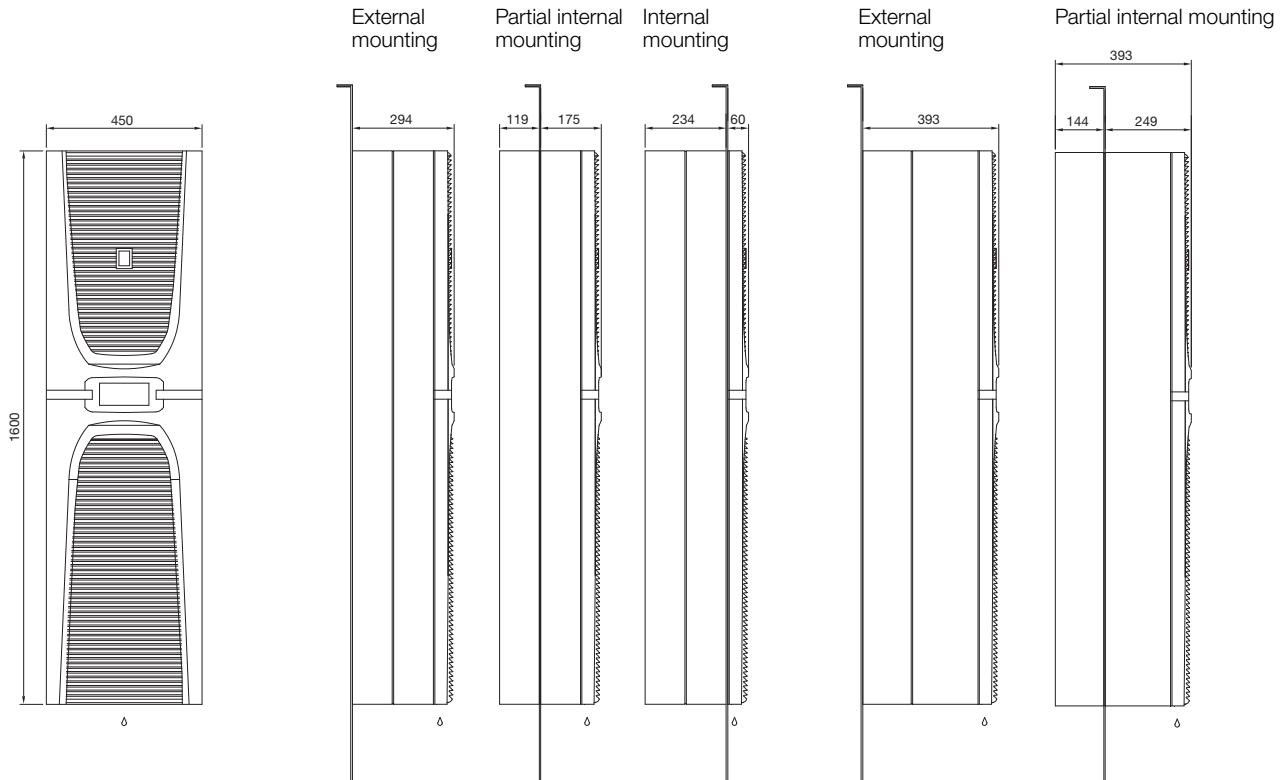

Mounting cut-out  
External mounting, partial internal mounting, internal mounting for door, rear and side panel,  $W \geq 600$  mm

Mounting cut-out  
External mounting rear and side panel,  $W = 500$  mm

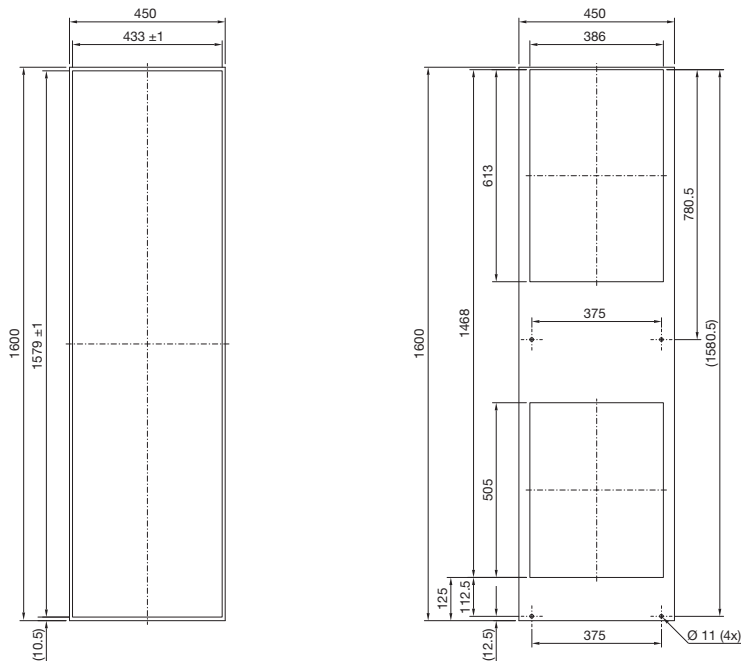

#### Important installation instructions for full internal mounting

- Not generally possible for 4.2 and 5.8 kW
- For 600 mm wide enclosure doors, please note: Move the cut-out towards the door hinge by 25 mm, and dismantle the tubular door frame

#### Important installation instructions for external mounting on 500 mm deep enclosures

- Partial internal mounting and full internal mounting not supported
- External mounting only possible with mounting cut-out for 500 mm deep enclosures



### Wall-mounted cooling units

Blue e+ SK 3185.830

Installation options SK 3185.830

External mounting

Partial internal mounting

Internal mounting

Mounting cut-out  
External mounting, partial internal mounting, internal mounting

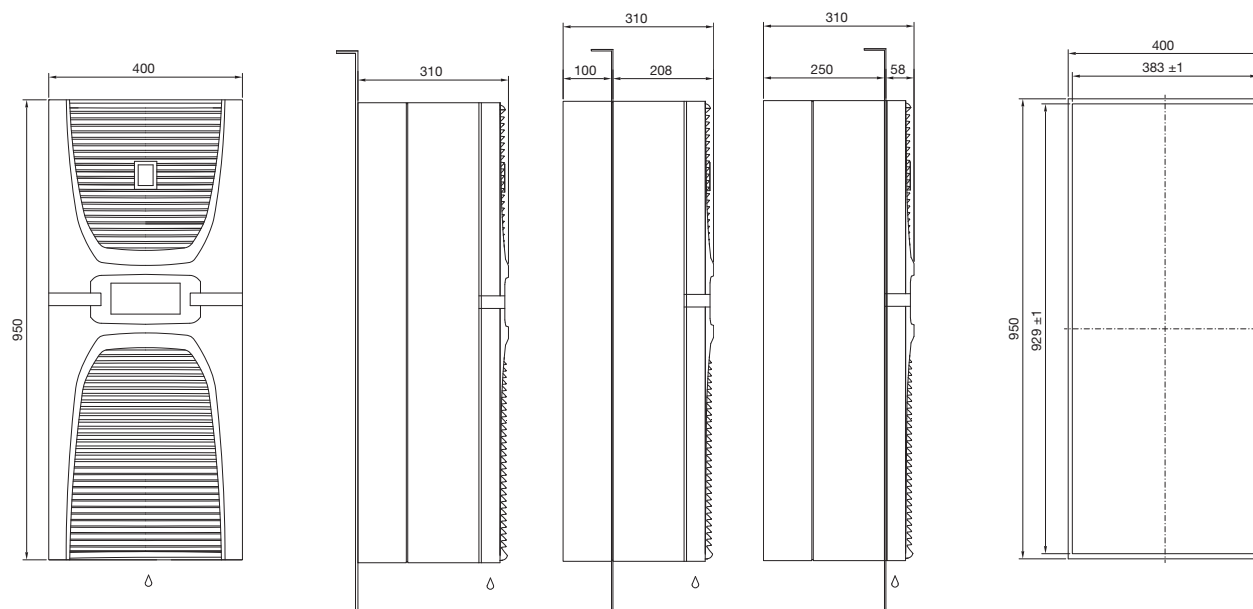

### Overview of all Blue e+ information

#### Design made easy

- Detailed climate control calculation with the Therm software
- Therm app enables rapid parameterisation

[www.rittal.com/therm](http://www.rittal.com/therm)

#### Item information

- Product description and features
- Assembly instructions
- Approvals
- Interactive performance diagrams
- CAD drawings

[www.rittal.com/blue\\_e\\_plus\\_wallmount](http://www.rittal.com/blue_e_plus_wallmount)

#### The Blue e+ microsite

- Calculate potential savings and amortisation periods with the efficiency calculator
- Full information on the energy label and the SEER
- Videos showing technical details:
  - Heat pipe
  - Multi-voltage support
  - Intelligent interfaces and Blue e+ app
- Service messages may easily be sent with the Blue e+ app via an NFC interface and much more besides can be found at

[www.rittal.com/blue\\_e\\_plus](http://www.rittal.com/blue_e_plus)

# Wall-mounted cooling units Blue e+

## Technical details

### TopTherm wall-mounted cooling units Blue e+

Output class 1600 W (110 – 240 V, 1 ~, 50 – 60 Hz / 380 – 480 V, 3 ~, 50 – 60 Hz)

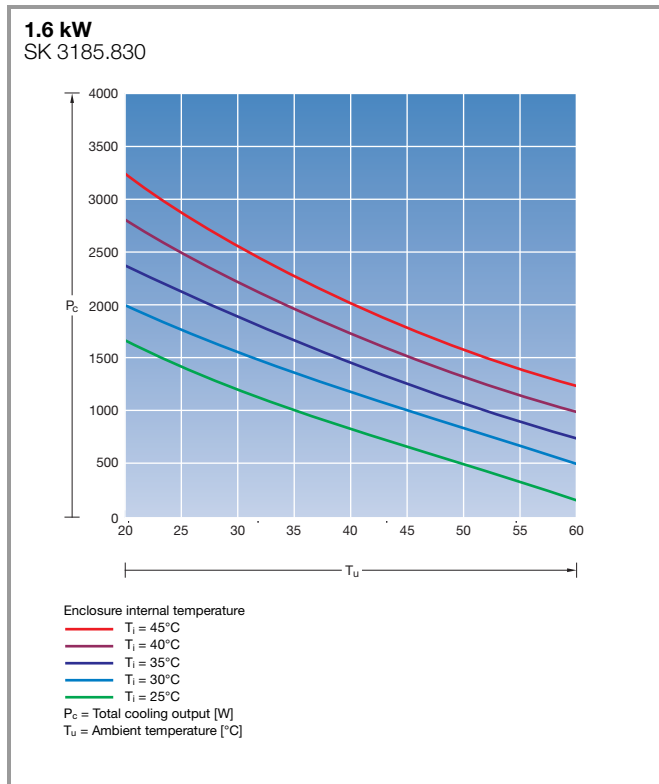

Output class 2000/2600 W (110 – 240 V, 1 ~, 50 – 60 Hz / 380 – 480 V, 3 ~, 50 – 60 Hz)

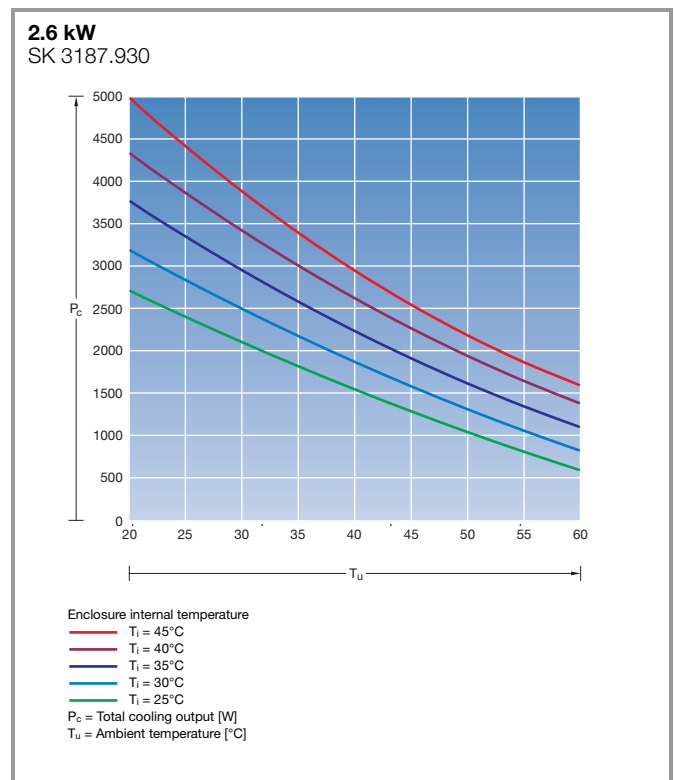
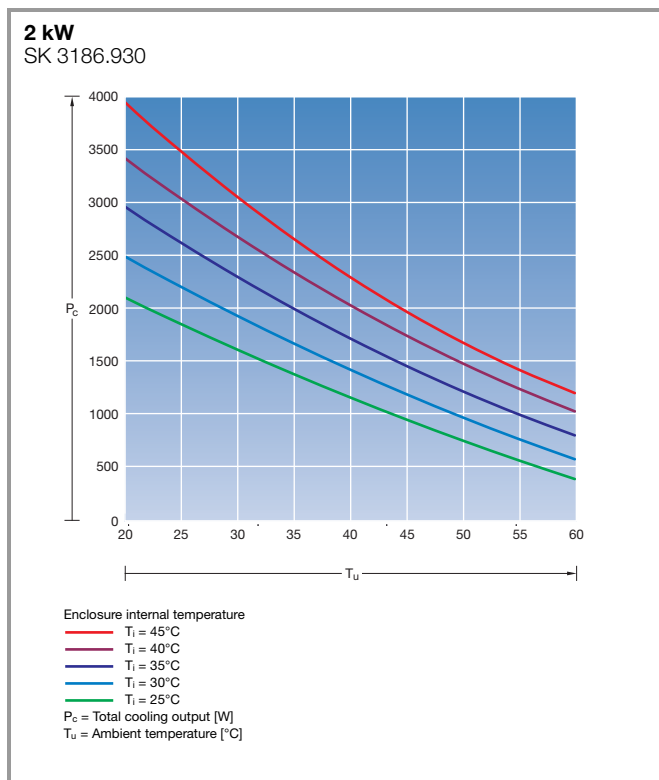

# Wall-mounted cooling units Blue e+

## Technical details

Output category 4200/5800 W (380 – 480 V, 3 ~, 50 – 60 Hz)

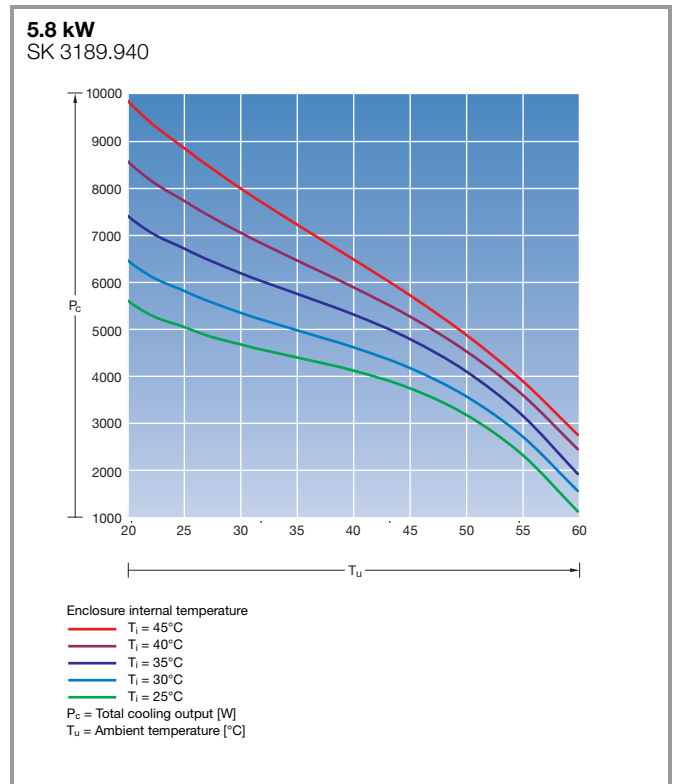
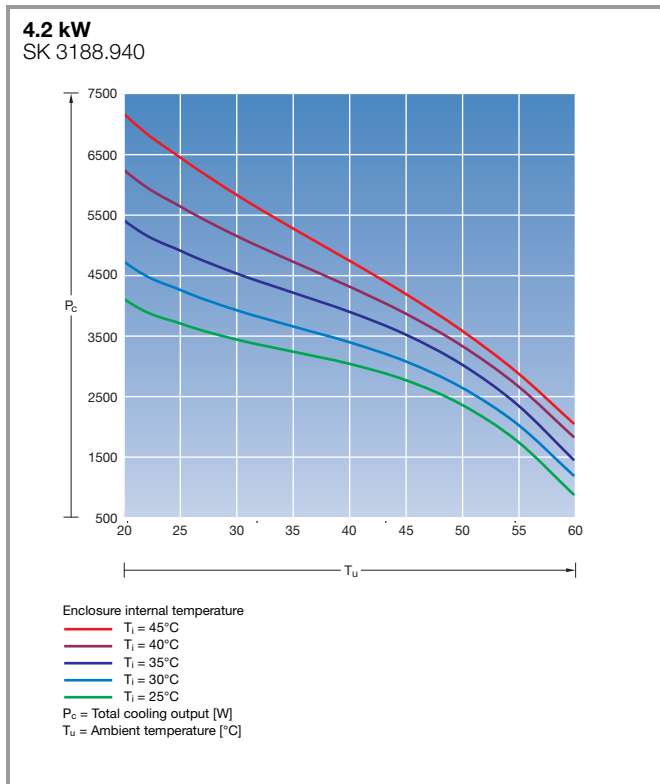

# Rittal – The System.

Faster – better – everywhere.

- Enclosures
- Power Distribution
- Climate Control
- IT Infrastructure
- Software & Services

You can find the contact details of all Rittal companies throughout the world here.



[www.rittal.com/contact](http://www.rittal.com/contact)

ENCLOSURES

POWER DISTRIBUTION

CLIMATE CONTROL

IT INFRASTRUCTURE

SOFTWARE & SERVICES



FRIEDHELM LOH GROUP