



Visualisation; Diagnostics

Easy to Configure

Programming IEC 61131-3

Rapid Installation

## PZE 9P

► Safety relays

**PILZ**  
THE SPIRIT OF SAFETY

This document is the original document.

All rights to this documentation are reserved by Pilz GmbH & Co. KG. Copies may be made for the user's internal purposes. Suggestions and comments for improving this documentation will be gratefully received.

Source code from third-party manufacturers or open source software has been used for some components. The relevant licence information is available on the Internet on the Pilz homepage.

Pilz®, PIT®, PMI®, PNOZ®, Primo®, PSEN®, PSS®, PVIS®, SafetyBUS p®, SafetyEYE®, SafetyNET p®, the spirit of safety® are registered and protected trademarks of Pilz GmbH & Co. KG in some countries.



SD means Secure Digital

<b>Introduction</b>	<b>5</b>
Validity of documentation	5
Using the documentation	5
Definition of symbols	5
<b>Safety</b>	<b>6</b>
Intended use	6
Safety regulations	6
Safety assessment	6
Use of qualified personnel	7
Warranty and liability	7
Disposal	7
For your safety	7
<b>Unit features</b>	<b>8</b>
<b>Safety features</b>	<b>8</b>
<b>Block diagram/terminal configuration</b>	<b>8</b>
Type: 24 V AC/DC	8
Type: 24 - 240 V AC/DC	9
<b>Function description</b>	<b>9</b>
<b>Installation</b>	<b>9</b>
<b>Wiring</b>	<b>10</b>
<b>Preparing for operation</b>	<b>10</b>
<b>Operation</b>	<b>11</b>
Status indicators	12
<b>Faults – Interference</b>	<b>12</b>
<b>Dimensions in mm</b>	<b>12</b>
<b>Technical details</b>	<b>13</b>
Safety characteristic data	24
<b>Supplementary data</b>	<b>25</b>
Service life graph	25

<b>Remove plug-in terminals</b>	<b>26</b>
<b>Order reference</b>	<b>26</b>
<b>EC declaration of conformity</b>	<b>26</b>

## Introduction

### Validity of documentation

This documentation is valid for the product PZE 9P. It is valid until new documentation is published.

This operating manual explains the function and operation, describes the installation and provides guidelines on how to connect the product.

### Using the documentation

This document is intended for instruction. Only install and commission the product if you have read and understood this document. The document should be retained for future reference.

### Definition of symbols

Information that is particularly important is identified as follows:



#### **DANGER!**

This warning must be heeded! It warns of a hazardous situation that poses an immediate threat of serious injury and death and indicates preventive measures that can be taken.



#### **WARNING!**

This warning must be heeded! It warns of a hazardous situation that could lead to serious injury and death and indicates preventive measures that can be taken.



#### **CAUTION!**

This refers to a hazard that can lead to a less serious or minor injury plus material damage, and also provides information on preventive measures that can be taken.



#### **NOTICE**

This describes a situation in which the product or devices could be damaged and also provides information on preventive measures that can be taken. It also highlights areas within the text that are of particular importance.

**INFORMATION**

This gives advice on applications and provides information on special features.

**Safety****Intended use**

The contact expansion module PZE 9P meets the requirements of EN 60947-5-1, EN 60204-1 and VDE 0113-1. It is an expansion module for increasing the number of contacts available on a base unit. Base units are all

- ▶ Safety relays with feedback loop
- ▶ programmable safety systems with feedback loop

The max. achievable safety level depends on the base unit. The expansion module may not exceed this. The safety-related characteristic values stated under [Safety-related characteristic data](#) [ 24] can only be achieved if the base unit also exhibits these values.

The following is deemed improper use in particular

- ▶ Any component, technical or electrical modification to the product,
- ▶ Use of the product outside the areas described in this manual,
- ▶ Use of the product outside the technical details (see [Technical details](#) [ 13]).

**NOTICE****EMC-compliant electrical installation**

The product is designed for use in an industrial environment. The product may cause interference if installed in other environments. If installed in other environments, measures should be taken to comply with the applicable standards and directives for the respective installation site with regard to interference.

**Safety regulations****Safety assessment**

Before using a device it is necessary to perform a safety assessment in accordance with the Machinery Directive.

Functional safety is guaranteed for the product as a single component. However, this does not guarantee the functional safety of the overall plant/machine. In order to achieve the required safety level for the overall plant/machine, define the safety requirements for the plant/machine and then define how these must be implemented from a technical and organisational standpoint.

### Use of qualified personnel

The products may only be assembled, installed, programmed, commissioned, operated, maintained and decommissioned by competent persons.

A competent person is a qualified and knowledgeable person who, because of their training, experience and current professional activity, has the specialist knowledge required. To be able to inspect, assess and operate devices, systems and machines, the person has to be informed of the state of the art and the applicable national, European and international laws, directives and standards.

It is the company's responsibility only to employ personnel who

- ▶ Are familiar with the basic regulations concerning health and safety / accident prevention,
- ▶ Have read and understood the information provided in the section entitled Safety
- ▶ Have a good knowledge of the generic and specialist standards applicable to the specific application.

### Warranty and liability

All claims to warranty and liability will be rendered invalid if

- ▶ The product was used contrary to the purpose for which it is intended,
- ▶ Damage can be attributed to not having followed the guidelines in the manual,
- ▶ Operating personnel are not suitably qualified,
- ▶ Any type of modification has been made (e.g. exchanging components on the PCB boards, soldering work etc.).

### Disposal

- ▶ In safety-related applications, please comply with the mission time  $T_M$  in the safety-related characteristic data.
- ▶ When decommissioning, please comply with local regulations regarding the disposal of electronic devices (e.g. Electrical and Electronic Equipment Act).

### For your safety

The unit meets all the necessary conditions for safe operation. However, please note the following:

- ▶ Note for overvoltage category III: If voltages higher than low voltage (>50 VAC or >120 VDC) are present on the unit, connected control elements and sensors must have a rated insulation voltage of at least 250 V.

## Unit features

- ▶ Positive-guided relay outputs:
  - 8 safety contacts (N/O), instantaneous
  - 1 auxiliary contact (N/C), instantaneous
- ▶ LED display for:
  - Supply voltage
  - Switch status of the safety contacts
- ▶ Connection for feedback loop
- ▶ Operation: Single or dual-channel
- ▶ Plug-in connection terminals (either spring-loaded terminal or screw terminal)
- ▶ See order reference for unit types

## Safety features

The unit meets the following safety requirements:

- ▶ The contact expander module expands an existing circuit. As the output relays are monitored via the base unit's feedback loop, the safety functions on the existing circuit are transferred to the contact expander module.
- ▶ The safety function remains effective in the case of a component failure.
- ▶ Earth fault in the feedback loop:  
Detected, depending on the base unit that is used.
- ▶ Earth fault in the input circuit:  
The output relays de-energise and the safety contacts open.

## Block diagram/terminal configuration

### Type: 24 V AC/DC

- ▶  $U_B$ : 24 VAC/DC; Order no. 777140, 787140

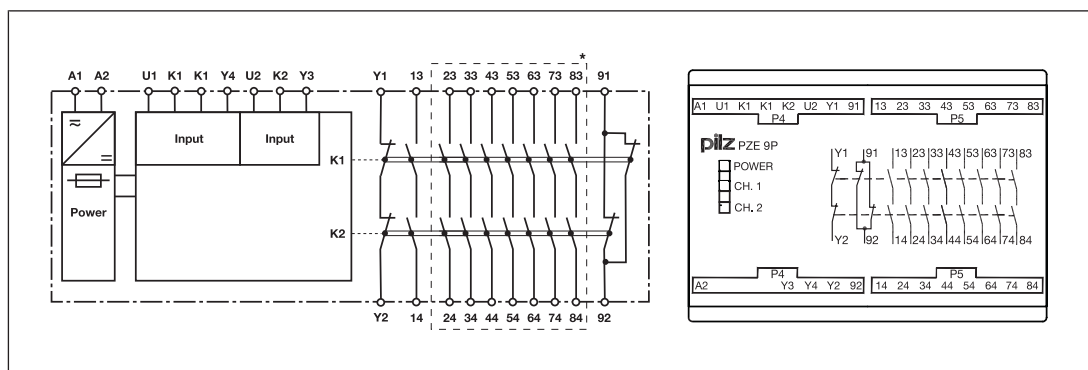

\*Safe separation from non-marked area, except for safety contact 13-14, in accordance with EN 60947-1, 6 kV, basic insulation between all safety contacts.



**Type: 24 - 240 V AC/DC**

- ▶  $U_B$ : 24 - 240 VAC/DC, 24 VAC/DC; Order no. 777148, 787148

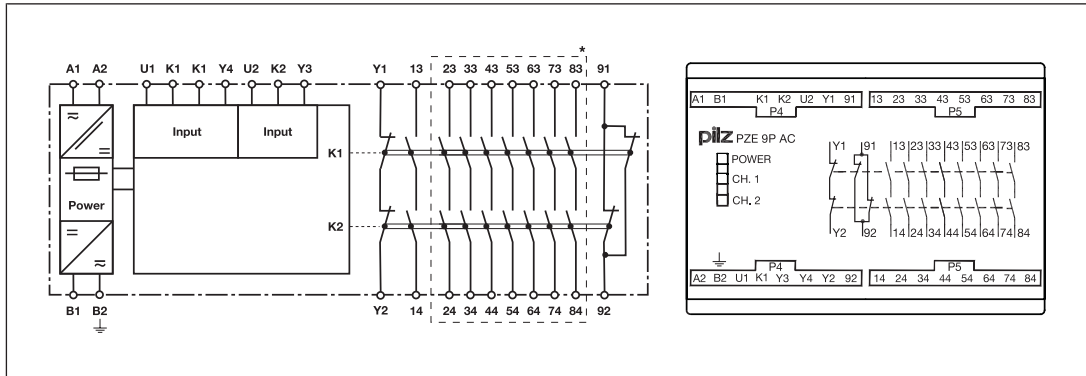

\*Safe separation from non-marked area, except for safety contact 13-14, in accordance with EN 60947-1, 6 kV, basic insulation between all safety contacts.

**Function description**

The contact expansion module PZE 9P is an add-on device without delay-on de-energisation. It is used to expand a safety circuit. The contact expansion module is driven by a base unit (e. g. emergency stop relay). When operating voltage is supplied the "POWER" LED will light.

- ▶ Functional procedure once the input circuit is closed (e.g. safety contacts on the base unit are closed):
  - Safety contacts 13-14, 23-24, 33-34, 43-44, 53-54, 63-64, 73-74 and 83-84 close, auxiliary contact 91-92 opens.
  - The LEDs "CH.1" and "CH.2" are lit.
- ▶ Functional procedure once the input circuit is opened (e.g. safety contacts on the base unit are opened):
  - Safety contacts 13-14, 23-24, 33-34, 43-44, 53-54, 63-64, 73-74 and 83-84 are opened redundantly, auxiliary contact 91-92 is closed.
  - The LEDs "CH.1" and "CH.2" go out.

**Installation**

- ▶ The unit should be installed in a control cabinet with a protection type of at least IP54.
- ▶ Use the notch on the rear of the unit to attach it to a DIN rail (35 mm).
- ▶ When installed vertically: Secure the unit by using a fixing element (e.g. retaining bracket or end angle).

## Wiring

Please note:

- ▶ Information given in the "Technical details [13]" must be followed.
- ▶ Outputs 13-14, 23-24, 33-34, 43-44, 53-54, 63-64, 73-74, 83-84 are safety contacts; output 91-92 is an auxiliary contact (e.g. for display).
- ▶ Do **not** use auxiliary contact 91-92 for safety circuits!
- ▶ Do not connect undesignated terminals.
- ▶ To prevent contact welding, a fuse should be connected before the output contacts (see Technical details [13]).
- ▶ Calculation of the max. cable length  $l_{max}$  in the input circuit:

$$l_{max} = \frac{R_{lmax}}{R_l / km}$$

$R_{lmax}$  = max. overall cable resistance (see Technical details [13])

$R_l / km$  = cable resistance/km

- ▶ Use copper wire that can withstand 60/75 °C.
- ▶ Sufficient fuse protection must be provided on all output contacts with capacitive and inductive loads.
- ▶ Do not switch low currents using contacts that have been used previously with high currents.
- ▶ 777140, 787140 units or 777148, 787148 units, when the supply voltage is connected via B1 and B2: The power supply must comply with the regulations for extra low voltages with safe electrical separation (SELV, PELV) in accordance with VDE 0100, Part 410.
- ▶ Ensure the wiring and EMC requirements of EN 60204-1 are met.

## Preparing for operation

Supply voltage	24 - 240 V AC/DC	24 VAC/DC
Order no.: 777148, 787148		
Order no.: 777140, 787140	/	

Input circuit	Single-channel	Dual-channel
<p><b>without</b> detection of shorts across contacts</p> <p>Base unit: Safety relay PNOZ X</p> <p>Driven via safety contacts</p>		
<p><b>with</b> detection of shorts across contacts</p> <p>Base unit: Safety relay PNOZ X</p> <p>Driven via safety contacts</p>		
<p><b>without</b> detection of shorts across contacts</p> <p>Base unit: Safety system or PNOZmulti</p> <p>Driven via safe semiconductor outputs (24 VDC)</p>		
Feedback loop	Base unit: Safety relay PNOZ X	Base unit: Safety system or PNOZmulti
<p>Y1, Y2 and Input are inputs on the base unit; they evaluate the feedback loop</p>		

### Operation

When the relay outputs are switched on, the mechanical contact on the relay cannot be tested automatically. Depending on the operational environment, measures to detect the non-opening of switching elements may be required under some circumstances.

When the product is used in accordance with the European Machinery Directive, a check must be carried out to ensure that the safety contacts on the relay outputs open correctly. Open the safety contacts of the contact expansion module (switch off outputs of the base unit) and start the base unit again so that the internal diagnostics can check that the safety contacts open correctly

- ▶ for SIL CL 3/PL e at least 1x per month
- ▶ for SIL CL 2/PL d at least 1x per year

**NOTICE**

The safety function should be checked after initial commissioning and each time the plant/machine is changed. The safety functions may only be checked by qualified personnel.

**Status indicators**

LEDs indicate the status and errors during operation:



LED on

**POWER**

Supply voltage is present.

**CH.1**

Safety contacts of channel 1 are closed.

**CH.2**

Safety contacts of channel 2 are closed.

**Faults – Interference**

By closing or interrupting the input circuit you can check whether the unit switches on or off correctly.

For safety reasons, the unit cannot be started if the following faults are present:

- ▶ Contact malfunction: As the contact block is connected to a base unit, reactivation will not be possible if the contacts have welded after the input circuit has opened.
- ▶ Open circuit, short circuit or earth fault ( e.g. in the input circuit)

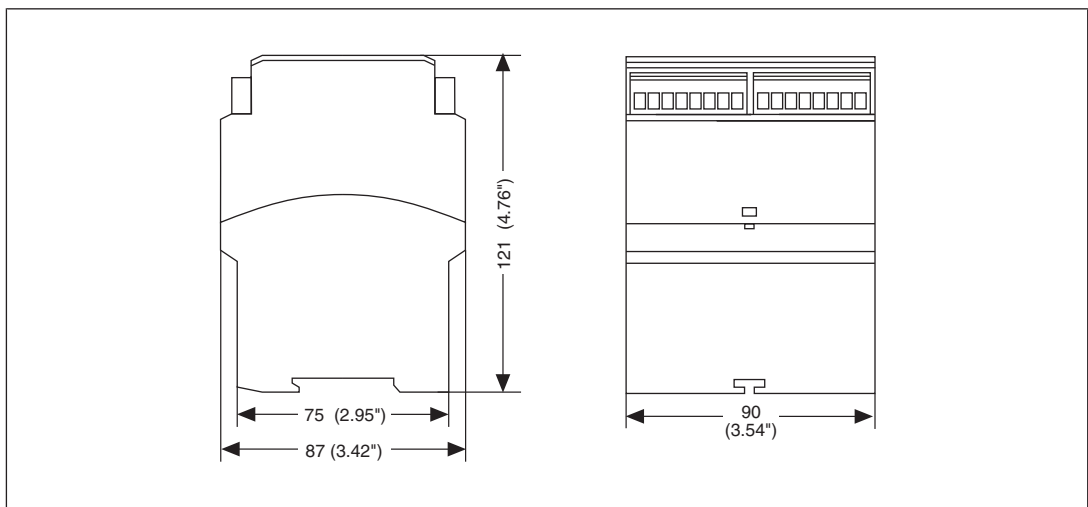
**Dimensions in mm**

## Technical details

Order no. 777140 – 787140

See below for more order numbers

<b>General</b>	<b>777140</b>	<b>787140</b>
Approvals	CCC, CE, EAC (Eurasian), TÜV, cULus Listed	CCC, CE, EAC (Eurasian), TÜV, cULus Listed
<b>Electrical data</b>	<b>777140</b>	<b>787140</b>
Supply voltage		
Voltage	<b>24 V</b>	<b>24 V</b>
Kind	<b>AC/DC</b>	<b>AC/DC</b>
Voltage tolerance	<b>-15 %/+10 %</b>	<b>-15 %/+10 %</b>
Output of external power supply (AC)	<b>9,5 VA</b>	<b>9,5 VA</b>
Output of external power supply (DC)	<b>3,5 W</b>	<b>3,5 W</b>
Frequency range AC	<b>50 - 60 Hz</b>	<b>50 - 60 Hz</b>
Residual ripple DC	<b>160 %</b>	<b>160 %</b>
Duty cycle	<b>100 %</b>	<b>100 %</b>
<b>Inputs</b>	<b>777140</b>	<b>787140</b>
Number	<b>2</b>	<b>2</b>
Voltage at		
Input circuit DC	<b>24 V</b>	<b>24 V</b>
Current at		
Input circuit DC	<b>40 mA</b>	<b>40 mA</b>
Max. overall cable resistance RI-max		
Single-channel at UB DC	<b>50 Ohm</b>	<b>50 Ohm</b>
Single-channel at UB AC	<b>80 Ohm</b>	<b>80 Ohm</b>
Dual-channel without detection of shorts across contacts at UB DC	<b>100 Ohm</b>	<b>100 Ohm</b>
Dual-channel without detection of shorts across contacts at UB AC	<b>160 Ohm</b>	<b>160 Ohm</b>
Dual-channel with detection of shorts across contacts at UB DC	<b>5 Ohm</b>	<b>5 Ohm</b>
Dual-channel with detection of shorts across contacts at UB AC	<b>10 Ohm</b>	<b>10 Ohm</b>
<b>Relay outputs</b>	<b>777140</b>	<b>787140</b>
Number of output contacts		
Safety contacts (N/O), instantaneous	<b>8</b>	<b>8</b>
Auxiliary contacts (N/C)	<b>1</b>	<b>1</b>
Max. short circuit current IK	<b>1 kA</b>	<b>1 kA</b>

<b>Relay outputs</b>	<b>777140</b>	<b>787140</b>
Utilisation category		
In accordance with the standard	<b>EN 60947-4-1</b>	<b>EN 60947-4-1</b>
Utilisation category of safety con- tacts		
AC1 at	<b>240 V</b>	<b>240 V</b>
Min. current	<b>0,01 A</b>	<b>0,01 A</b>
Max. current	<b>8 A</b>	<b>8 A</b>
Max. power	<b>2000 VA</b>	<b>2000 VA</b>
DC1 at	<b>24 V</b>	<b>24 V</b>
Min. current	<b>0,01 A</b>	<b>0,01 A</b>
Max. current	<b>8 A</b>	<b>8 A</b>
Max. power	<b>200 W</b>	<b>200 W</b>
Utilisation category of auxiliary con- tacts		
AC1 at	<b>240 V</b>	<b>240 V</b>
Min. current	<b>0,01 A</b>	<b>0,01 A</b>
Max. current	<b>2 A</b>	<b>2 A</b>
Max. power	<b>500 VA</b>	<b>500 VA</b>
DC1 at	<b>24 V</b>	<b>24 V</b>
Min. current	<b>0,01 A</b>	<b>0,01 A</b>
Max. current	<b>2 A</b>	<b>2 A</b>
Max. power	<b>50 W</b>	<b>50 W</b>
Utilisation category		
In accordance with the standard	<b>EN 60947-5-1</b>	<b>EN 60947-5-1</b>
Utilisation category of safety con- tacts		
AC15 at	<b>230 V</b>	<b>230 V</b>
Max. current	<b>5 A</b>	<b>5 A</b>
DC13 (6 cycles/min) at	<b>24 V</b>	<b>24 V</b>
Max. current	<b>7 A</b>	<b>7 A</b>
Utilisation category of auxiliary con- tacts		
AC15 at	<b>230 V</b>	<b>230 V</b>
Max. current	<b>2 A</b>	<b>2 A</b>
DC13 (6 cycles/min) at	<b>24 V</b>	<b>24 V</b>
Max. current	<b>2 A</b>	<b>2 A</b>
Utilisation category in accordance with UL		
Voltage	<b>240 V AC G. P.</b>	<b>240 V AC G. P.</b>
With current	<b>8 A</b>	<b>8 A</b>
Voltage	<b>24 V DC G. P. Resistive</b>	<b>24 V DC G. P. Resistive</b>
With current	<b>5 A</b>	<b>5 A</b>
Pilot Duty	<b>B300, R300</b>	<b>B300, R300</b>

<b>Relay outputs</b>	<b>777140</b>	<b>787140</b>
External contact fuse protection, safety contacts		
In accordance with the standard	<b>EN 60947-5-1</b>	<b>EN 60947-5-1</b>
Max. melting integral	<b>240 A<sup>2</sup>s</b>	<b>240 A<sup>2</sup>s</b>
Blow-out fuse, quick	<b>10 A</b>	<b>10 A</b>
Blow-out fuse, slow	<b>6 A</b>	<b>6 A</b>
Blow-out fuse, gG	<b>10 A</b>	<b>10 A</b>
Circuit breaker 24V AC/DC, characteristic B/C	<b>6 A</b>	<b>6 A</b>
External contact fuse protection, auxiliary contacts		
Max. melting integral	<b>240 A<sup>2</sup>s</b>	<b>240 A<sup>2</sup>s</b>
Blow-out fuse, quick	<b>4 A</b>	<b>4 A</b>
Blow-out fuse, slow	<b>2 A</b>	<b>2 A</b>
Blow-out fuse, gG	<b>4 A</b>	<b>4 A</b>
Circuit breaker 24 V AC/DC, characteristic B/C	<b>2 A</b>	<b>2 A</b>
Contact material	<b>AgSnO<sub>2</sub> + 0,2 µm Au</b>	<b>AgSnO<sub>2</sub> + 0,2 µm Au</b>
<b>Conventional thermal current while loading several contacts</b>	<b>777140</b>	<b>787140</b>
I <sub>th</sub> per contact at UB AC; AC1: 240 V, DC1: 24 V		
Conv. therm. current with 1 contact	<b>8 A</b>	<b>8 A</b>
Conv. therm. current with 2 contacts	<b>8 A</b>	<b>8 A</b>
Conv. therm. current with 3 contacts	<b>8 A</b>	<b>8 A</b>
Conv. therm. current with 4 contacts	<b>7,1 A</b>	<b>7,1 A</b>
Conv. therm. current with 5 contacts	<b>6,3 A</b>	<b>6,3 A</b>
Conv. therm. current with 6 contacts	<b>5,8 A</b>	<b>5,8 A</b>
Conv. therm. current with 7 contacts	<b>5,4 A</b>	<b>5,4 A</b>
Conv. therm. current with 8 contacts	<b>5 A</b>	<b>5 A</b>

<b>Conventional thermal current while loading several contacts</b>	<b>777140</b>	<b>787140</b>
Ith per contact at UB DC; AC1: 240 V, DC1: 24 V		
Conv. therm. current with 1 contact	8 A	8 A
Conv. therm. current with 2 contacts	8 A	8 A
Conv. therm. current with 3 contacts	8 A	8 A
Conv. therm. current with 4 contacts	7,1 A	7,1 A
Conv. therm. current with 5 contacts	6,3 A	6,3 A
Conv. therm. current with 6 contacts	5,8 A	5,8 A
Conv. therm. current with 7 contacts	5,4 A	5,4 A
Conv. therm. current with 8 contacts	5 A	5 A
<b>Times</b>	<b>777140</b>	<b>787140</b>
Switch-on delay		
With automatic start typ.	30 ms	30 ms
With automatic start max.	40 ms	40 ms
With automatic start after power on typ.	30 ms	30 ms
With automatic start after power on max.	40 ms	40 ms
Delay-on de-energisation		
With E-STOP typ.	20 ms	20 ms
With E-STOP max.	30 ms	30 ms
With power failure typ.	110 ms	110 ms
With power failure max.	200 ms	200 ms
Supply interruption before de-energisation in the input circuit	10 ms	10 ms
Supply interruption before de-energisation	20 ms	20 ms
<b>Environmental data</b>	<b>777140</b>	<b>787140</b>
Climatic suitability	EN 60068-2-78	EN 60068-2-78
Ambient temperature		
Temperature range	-10 - 55 °C	-10 - 55 °C
Storage temperature		
Temperature range	-40 - 85 °C	-40 - 85 °C
Climatic suitability		
Humidity	93 % r. h. at 40 °C	93 % r. h. at 40 °C
Condensation during operation	Not permitted	Not permitted
EMC	EN 60947-5-1, EN 61000-6-2, EN 61326-3-1	EN 60947-5-1, EN 61000-6-2, EN 61326-3-1



<b>Environmental data</b>	<b>777140</b>	<b>787140</b>
Vibration		
In accordance with the standard	<b>EN 60068-2-6</b>	<b>EN 60068-2-6</b>
Frequency	<b>10 - 55 Hz</b>	<b>10 - 55 Hz</b>
Amplitude	<b>0,35 mm</b>	<b>0,35 mm</b>
Airgap creepage		
In accordance with the standard	<b>EN 60947-1</b>	<b>EN 60947-1</b>
Overvoltage category	<b>III</b>	<b>III</b>
Pollution degree	<b>2</b>	<b>2</b>
Rated insulation voltage	<b>250 V</b>	<b>250 V</b>
Rated impulse withstand voltage	<b>6 kV</b>	<b>6 kV</b>
Protection type		
Housing	<b>IP40</b>	<b>IP40</b>
Terminals	<b>IP20</b>	<b>IP20</b>
Mounting area (e.g. control cabinet)	<b>IP54</b>	<b>IP54</b>
<b>Mechanical data</b>	<b>777140</b>	<b>787140</b>
Mounting position	<b>Any</b>	<b>Any</b>
Mechanical life	<b>10,000,000 cycles</b>	<b>10,000,000 cycles</b>
Material		
Bottom	<b>PPO UL 94 V0</b>	<b>PPO UL 94 V0</b>
Front	<b>ABS UL 94 V0</b>	<b>ABS UL 94 V0</b>
Top	<b>PPO UL 94 V0</b>	<b>PPO UL 94 V0</b>
Connection type	<b>Screw terminal</b>	<b>Spring-loaded terminal</b>
Mounting type	<b>plug-in</b>	<b>plug-in</b>
Conductor cross section with screw terminals		
1 core flexible	<b>0,25 - 2,5 mm<sup>2</sup>, 24 - 12 AWG</b>	–
2 core with the same cross section, flexible with crimp connectors, no plastic sleeve	<b>0,25 - 1 mm<sup>2</sup>, 24 - 16 AWG</b>	–
2 core with the same cross section, flexible without crimp connectors or with TWIN crimp connectors	<b>0,2 - 1,5 mm<sup>2</sup>, 24 - 16 AWG</b>	–
Torque setting with screw terminals	<b>0,5 Nm</b>	–
Conductor cross section with spring-loaded terminals: Flexible with/without crimp connector	–	<b>0,2 - 1,5 mm<sup>2</sup>, 24 - 16 AWG</b>
Spring-loaded terminals: Terminal points per connection	–	<b>2</b>
Stripping length with spring-loaded terminals	–	<b>8 mm</b>
Dimensions		
Height	<b>87 mm</b>	<b>87 mm</b>
Width	<b>90 mm</b>	<b>90 mm</b>
Depth	<b>121 mm</b>	<b>121 mm</b>
Weight	<b>430 g</b>	<b>430 g</b>

Where standards are undated, the 2017-01 latest editions shall apply.

**Order no. 777148 – 787148**

<b>General</b>	<b>777148</b>	<b>787148</b>
Approvals	CCC, CE, EAC (Eurasian), TÜV, cULus Listed	CCC, CE, EAC (Eurasian), TÜV, cULus Listed
<b>Electrical data</b>	<b>777148</b>	<b>787148</b>
Supply voltage		
Voltage	<b>24 - 240 V</b>	<b>24 - 240 V</b>
Kind	<b>AC/DC</b>	<b>AC/DC</b>
Voltage tolerance	<b>-15 %/+10 %</b>	<b>-15 %/+10 %</b>
Output of external power supply (AC)	<b>9,5 VA</b>	<b>9,5 VA</b>
Output of external power supply (DC)	<b>6 W</b>	<b>6 W</b>
Frequency range AC	<b>50 - 60 Hz</b>	<b>50 - 60 Hz</b>
Residual ripple DC	<b>160 %</b>	<b>160 %</b>
Supply voltage		
Voltage	<b>24 V</b>	<b>24 V</b>
Kind	<b>AC/DC</b>	<b>AC/DC</b>
Voltage tolerance	<b>-15 %/+10 %</b>	<b>-15 %/+10 %</b>
Output of external power supply (AC)	<b>9,5 VA</b>	<b>9,5 VA</b>
Output of external power supply (DC)	<b>3,5 W</b>	<b>3,5 W</b>
Frequency range AC	<b>50 - 60 Hz</b>	<b>50 - 60 Hz</b>
Residual ripple DC	<b>160 %</b>	<b>160 %</b>
Duty cycle	<b>100 %</b>	<b>100 %</b>
<b>Inputs</b>	<b>777148</b>	<b>787148</b>
Number	<b>2</b>	<b>2</b>
Voltage at		
Input circuit DC	<b>24 V</b>	<b>24 V</b>
Current at		
Input circuit DC	<b>40 mA</b>	<b>40 mA</b>

<b>Inputs</b>	<b>777148</b>	<b>787148</b>
Max. overall cable resistance Rl-max		
Single-channel at UB DC	<b>50 Ohm</b>	<b>50 Ohm</b>
Single-channel at UB AC	<b>80 Ohm</b>	<b>80 Ohm</b>
Dual-channel without detection of shorts across contacts at UB DC	<b>100 Ohm</b>	<b>100 Ohm</b>
Dual-channel without detection of shorts across contacts at UB AC	<b>160 Ohm</b>	<b>160 Ohm</b>
Dual-channel with detection of shorts across contacts at UB DC	<b>3 Ohm</b>	<b>3 Ohm</b>
Dual-channel with detection of shorts across contacts at UB AC	<b>8 Ohm</b>	<b>8 Ohm</b>
<b>Relay outputs</b>	<b>777148</b>	<b>787148</b>
Number of output contacts		
Safety contacts (N/O), instantaneous	<b>8</b>	<b>8</b>
Auxiliary contacts (N/C)	<b>1</b>	<b>1</b>
Max. short circuit current I <sub>K</sub>	<b>1 kA</b>	<b>1 kA</b>
Utilisation category		
In accordance with the standard	<b>EN 60947-4-1</b>	<b>EN 60947-4-1</b>
Utilisation category of safety contacts		
AC1 at	<b>240 V</b>	<b>240 V</b>
Min. current	<b>0,01 A</b>	<b>0,01 A</b>
Max. current	<b>8 A</b>	<b>8 A</b>
Max. power	<b>2000 VA</b>	<b>2000 VA</b>
DC1 at	<b>24 V</b>	<b>24 V</b>
Min. current	<b>0,01 A</b>	<b>0,01 A</b>
Max. current	<b>8 A</b>	<b>8 A</b>
Max. power	<b>200 W</b>	<b>200 W</b>
Utilisation category of auxiliary contacts		
AC1 at	<b>240 V</b>	<b>240 V</b>
Min. current	<b>0,01 A</b>	<b>0,01 A</b>
Max. current	<b>2 A</b>	<b>2 A</b>
Max. power	<b>500 VA</b>	<b>500 VA</b>
DC1 at	<b>24 V</b>	<b>24 V</b>
Min. current	<b>0,01 A</b>	<b>0,01 A</b>
Max. current	<b>2 A</b>	<b>2 A</b>
Max. power	<b>50 W</b>	<b>50 W</b>
Utilisation category		
In accordance with the standard	<b>EN 60947-5-1</b>	<b>EN 60947-5-1</b>

<b>Relay outputs</b>	<b>777148</b>	<b>787148</b>
Utilisation category of safety contacts		
AC15 at	<b>230 V</b>	<b>230 V</b>
Max. current	<b>5 A</b>	<b>5 A</b>
DC13 (6 cycles/min) at	<b>24 V</b>	<b>24 V</b>
Max. current	<b>7 A</b>	<b>7 A</b>
Utilisation category of auxiliary contacts		
AC15 at	<b>230 V</b>	<b>230 V</b>
Max. current	<b>2 A</b>	<b>2 A</b>
DC13 (6 cycles/min) at	<b>24 V</b>	<b>24 V</b>
Max. current	<b>2 A</b>	<b>2 A</b>
Utilisation category in accordance with UL		
Voltage	<b>240 V AC G. P.</b>	<b>240 V AC G. P.</b>
With current	<b>8 A</b>	<b>8 A</b>
Voltage	<b>24 V DC G. P. Resistive</b>	<b>24 V DC G. P. Resistive</b>
With current	<b>5 A</b>	<b>5 A</b>
Pilot Duty	<b>B300, R300</b>	<b>B300, R300</b>
External contact fuse protection, safety contacts		
In accordance with the standard	<b>EN 60947-5-1</b>	<b>EN 60947-5-1</b>
Max. melting integral	<b>240 A<sup>2</sup>s</b>	<b>240 A<sup>2</sup>s</b>
Blow-out fuse, quick	<b>10 A</b>	<b>10 A</b>
Blow-out fuse, slow	<b>6 A</b>	<b>6 A</b>
Blow-out fuse, gG	<b>10 A</b>	<b>10 A</b>
Circuit breaker 24V AC/DC, characteristic B/C	<b>6 A</b>	<b>6 A</b>
External contact fuse protection, auxiliary contacts		
Max. melting integral	<b>240 A<sup>2</sup>s</b>	<b>240 A<sup>2</sup>s</b>
Blow-out fuse, quick	<b>4 A</b>	<b>4 A</b>
Blow-out fuse, slow	<b>2 A</b>	<b>2 A</b>
Blow-out fuse, gG	<b>4 A</b>	<b>4 A</b>
Circuit breaker 24 V AC/DC, characteristic B/C	<b>2 A</b>	<b>2 A</b>
Contact material	<b>AgSnO<sub>2</sub> + 0,2 µm Au</b>	<b>AgSnO<sub>2</sub> + 0,2 µm Au</b>

<b>Conventional thermal current while loading several contacts</b>	<b>777148</b>	<b>787148</b>
Ith per contact at UB AC; AC1: 240 V, DC1: 24 V		
Conv. therm. current with 1 contact	<b>8 A</b>	<b>8 A</b>
Conv. therm. current with 2 contacts	<b>8 A</b>	<b>8 A</b>
Conv. therm. current with 3 contacts	<b>8 A</b>	<b>8 A</b>
Conv. therm. current with 4 contacts	<b>7,1 A</b>	<b>7,1 A</b>
Conv. therm. current with 5 contacts	<b>6,3 A</b>	<b>6,3 A</b>
Conv. therm. current with 6 contacts	<b>5,8 A</b>	<b>5,8 A</b>
Conv. therm. current with 7 contacts	<b>5,4 A</b>	<b>5,4 A</b>
Conv. therm. current with 8 contacts	<b>5 A</b>	<b>5 A</b>
Ith per contact at UB DC; AC1: 240 V, DC1: 24 V		
Conv. therm. current with 1 contact	<b>8 A</b>	<b>8 A</b>
Conv. therm. current with 2 contacts	<b>8 A</b>	<b>8 A</b>
Conv. therm. current with 3 contacts	<b>8 A</b>	<b>8 A</b>
Conv. therm. current with 4 contacts	<b>7,1 A</b>	<b>7,1 A</b>
Conv. therm. current with 5 contacts	<b>6,3 A</b>	<b>6,3 A</b>
Conv. therm. current with 6 contacts	<b>5,8 A</b>	<b>5,8 A</b>
Conv. therm. current with 7 contacts	<b>5,4 A</b>	<b>5,4 A</b>
Conv. therm. current with 8 contacts	<b>5 A</b>	<b>5 A</b>
<b>Times</b>	<b>777148</b>	<b>787148</b>
Switch-on delay		
With automatic start typ.	<b>30 ms</b>	<b>30 ms</b>
With automatic start max.	<b>40 ms</b>	<b>40 ms</b>
With automatic start after power on typ.	<b>300 ms</b>	<b>300 ms</b>
With automatic start after power on max.	<b>350 ms</b>	<b>350 ms</b>

<b>Times</b>	<b>777148</b>	<b>787148</b>
Delay-on de-energisation		
With E-STOP typ.	20 ms	20 ms
With E-STOP max.	30 ms	30 ms
With power failure typ.	200 ms	200 ms
With power failure max.	310 ms	310 ms
With power failure typ. UB 240 V	500 ms	500 ms
With power failure max. UB 240 V	630 ms	630 ms
With power failure typ. UB 24 V	150 ms	150 ms
With power failure max. UB 24 V	200 ms	200 ms
Supply interruption before de-energisation in the input circuit		
	10 ms	10 ms
Supply interruption before de-energisation		
	20 ms	20 ms
<b>Environmental data</b>	<b>777148</b>	<b>787148</b>
Climatic suitability		
	EN 60068-2-78	EN 60068-2-78
Ambient temperature		
Temperature range	-10 - 55 °C	-10 - 55 °C
Storage temperature		
Temperature range	-40 - 85 °C	-40 - 85 °C
Climatic suitability		
Humidity	93 % r. h. at 40 °C	93 % r. h. at 40 °C
Condensation during operation		
	Not permitted	Not permitted
EMC		
	EN 60947-5-1, EN 61000-6-2, EN 61326-3-1	EN 60947-5-1, EN 61000-6-2, EN 61326-3-1
Vibration		
In accordance with the standard	EN 60068-2-6	EN 60068-2-6
Frequency	10 - 55 Hz	10 - 55 Hz
Amplitude	0,35 mm	0,35 mm
Airgap creepage		
In accordance with the standard	EN 60947-1	EN 60947-1
Overvoltage category	III	III
Pollution degree	2	2
Rated insulation voltage		
	250 V	250 V
Rated impulse withstand voltage		
	6 kV	6 kV
Protection type		
Housing	IP40	IP40
Terminals	IP20	IP20
Mounting area (e.g. control cabinet)	IP54	IP54
<b>Mechanical data</b>	<b>777148</b>	<b>787148</b>
Mounting position		
	Any	Any
Mechanical life		
	10,000,000 cycles	10,000,000 cycles

<b>Mechanical data</b>	<b>777148</b>	<b>787148</b>
Material		
Bottom	<b>PPO UL 94 V0</b>	<b>PPO UL 94 V0</b>
Front	<b>ABS UL 94 V0</b>	<b>ABS UL 94 V0</b>
Top	<b>PPO UL 94 V0</b>	<b>PPO UL 94 V0</b>
Connection type	<b>Screw terminal</b>	<b>Spring-loaded terminal</b>
Mounting type	<b>plug-in</b>	<b>plug-in</b>
Conductor cross section with screw terminals		
1 core flexible	<b>0,25 - 2,5 mm<sup>2</sup>, 24 - 12 AWG</b>	–
2 core with the same cross section, flexible with crimp connectors, no plastic sleeve	<b>0,25 - 1 mm<sup>2</sup>, 24 - 16 AWG</b>	–
2 core with the same cross section, flexible without crimp connectors or with TWIN crimp connectors	<b>0,2 - 1,5 mm<sup>2</sup>, 24 - 16 AWG</b>	–
Torque setting with screw terminals	<b>0,5 Nm</b>	–
Conductor cross section with spring-loaded terminals: Flexible with/without crimp connector	–	<b>0,2 - 1,5 mm<sup>2</sup>, 24 - 16 AWG</b>
Spring-loaded terminals: Terminal points per connection	–	<b>2</b>
Stripping length with spring-loaded terminals	–	<b>8 mm</b>
Dimensions		
Height	<b>87 mm</b>	<b>87 mm</b>
Width	<b>90 mm</b>	<b>90 mm</b>
Depth	<b>121 mm</b>	<b>121 mm</b>
Weight	<b>455 g</b>	<b>455 g</b>

Where standards are undated, the 2017-01 latest editions shall apply.

**Safety characteristic data**



**NOTICE**

You must comply with the safety-related characteristic data in order to achieve the required safety level for your plant/machine.

Operating mode	EN ISO 13849-1: 2015	EN ISO 13849-1: 2015	EN 62061 SIL CL	EN 62061 PFH <sub>D</sub> [1/h]	IEC 61511 SIL	IEC 61511 PFD	EN ISO 13849-1: 2015 T <sub>M</sub> [year]
	PL	Category					
–	PL e	Cat. 4	SIL CL 3	2,31E-09	SIL 3	2,03E-06	20

All the units used within a safety function must be considered when calculating the safety characteristic data.



**INFORMATION**

A safety function's SIL/PL values are **not** identical to the SIL/PL values of the units that are used and may be different. We recommend that you use the PAscal software tool to calculate the safety function's SIL/PL values.



## Supplementary data



### CAUTION!

It is essential to consider the relay's service life graphs. The relay outputs' safety-related characteristic data is only valid if the values in the service life graphs are met.

The PFH value depends on the switching frequency and the load on the relay output. If the service life graphs are not accessible, the stated PFH value can be used irrespective of the switching frequency and the load, as the PFH value already considers the relay's B10d value as well as the failure rates of the other components.

### Service life graph

The service life graphs indicate the number of cycles from which failures due to wear must be expected. The wear is mainly caused by the electrical load; the mechanical load is negligible.

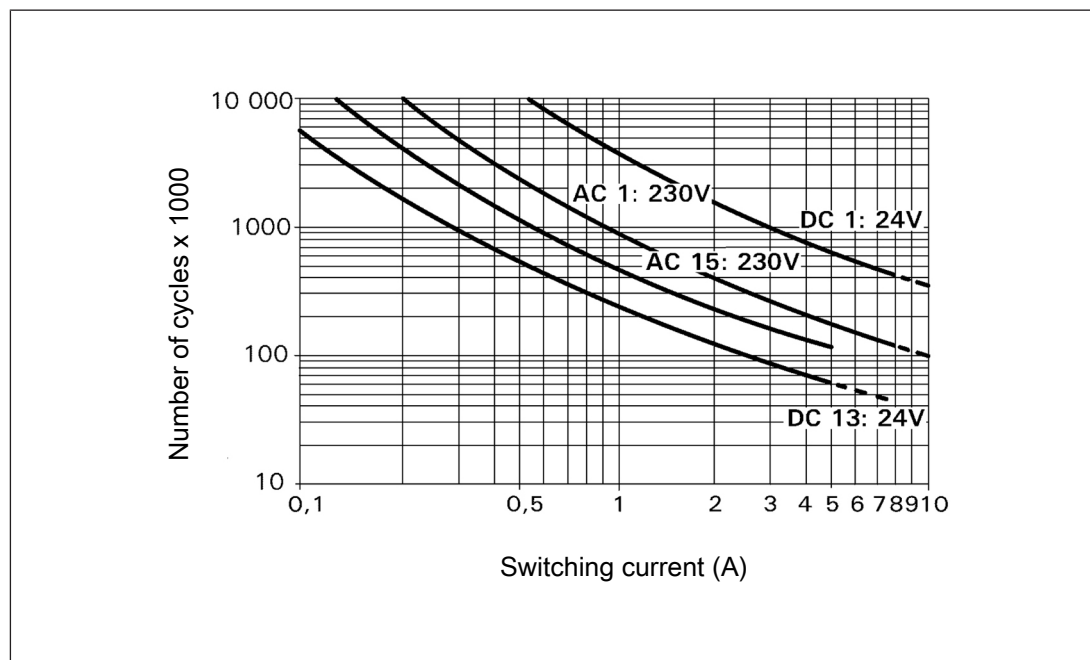

### Example

- ▶ Inductive load: 0.2 A
- ▶ Utilisation category: AC15
- ▶ Contact service life: 4 000 000 cycles

Provided the application to be implemented requires fewer than 4 000 000 cycles, the PFH value (see Technical details) can be used in the calculation.

To increase the service life, sufficient spark suppression must be provided on all output contacts. With capacitive loads, any power surges that occur must be noted. With DC contactors, use flywheel diodes for spark suppression.

## Remove plug-in terminals

Procedure: Insert the screwdriver into the housing recess behind the terminal and lever the terminal out.

Do **not** remove the terminals by pulling the cables!

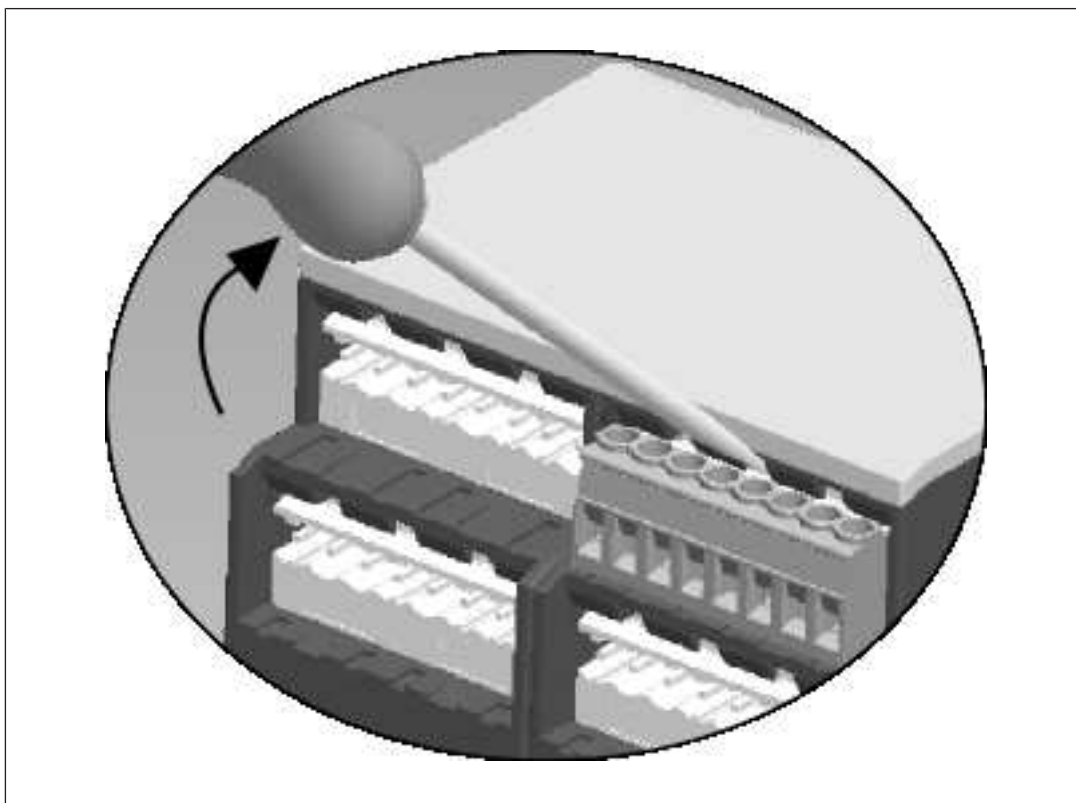

## Order reference

Product type	Features	Connection type	Order no.
PZE 9P C	24 VAC/DC	Spring-loaded terminals	787 140
PZE 9P	24 VAC/DC	Screw terminals	777 140
PZE 9P C	24 V AC/DC, 24 - 240 V AC/DC	Spring-loaded terminals	787 148
PZE 9P	24 V AC/DC, 24 - 240 V AC/DC	Screw terminals	777 148

## EC declaration of conformity

This product/these products meet the requirements of the directive 2006/42/EC for machinery of the European Parliament and of the Council. The complete EC Declaration of Conformity is available on the Internet at [www.pilz.com/downloads](http://www.pilz.com/downloads).

Authorised representative: Norbert Fröhlich, Pilz GmbH & Co. KG, Felix-Wankel-Str. 2, 73760 Ostfildern, Germany

# ► Support

Technical support is available from Pilz round the clock.

## Americas

### Brazil

+55 11 97569-2804

### Canada

+1 888-315-PILZ (315-7459)

### Mexico

+52 55 5572 1300

### USA (toll-free)

+1 877-PILZUSA (745-9872)

## Asia

### China

+86 21 60880878-216

### Japan

+81 45 471-2281

### South Korea

+82 31 450 0680

## Australia

+61 3 95600621

## Europe

### Austria

+43 1 7986263-0

### Belgium, Luxembourg

+32 9 3217575

### France

+33 3 88104000

### Germany

+49 711 3409-444

### Ireland

+353 21 4804983

### Italy, Malta

+39 0362 1826711

## Scandinavia

+45 74436332

## Spain

+34 938497433

## Switzerland

+41 62 88979-30

## The Netherlands

+31 347 320477

## Turkey

+90 216 5775552

## United Kingdom

+44 1536 462203

## You can reach our international hotline on:

+49 711 3409-444

support@pilz.com

Pilz develops environmentally-friendly products using ecological materials and energy-saving technologies. Offices and production facilities are ecologically designed, environmentally-aware and energy-saving. So Pilz offers sustainability, plus the security of using energy-efficient products and environmentally-friendly solutions.

*Energy*  
saving by Pilz



Pilz GmbH & Co. KG  
Felix-Wankel-Straße 2  
73760 Ostfildern, Germany  
Tel.: +49 711 3409-0  
Fax: +49 711 3409-133  
info@pilz.com  
www.pilz.com

**PILZ**  
THE SPIRIT OF SAFETY

CMSE®, IndurANET p®, PAS4000®, PASscal®, PASconfig®, Pilz®, PIT®, PLID®, PMCPirotego®, PMCiendo®, PMD®, PMI®, PNOZ®, Pirmo®, PSEN®, PSENi®, PSS®, PVIS®, SafetyBUS SafetyEYE®, SafetyNET p®, THE SPIRIT OF SAFETY® are registered and protected trademarks of Pilz GmbH & Co. KG in some countries. We would point out that product features mentioned in the details stated in this document, depending on the status at the time of publication and the scope of the equipment. We accept no responsibility for the validity, accuracy and entirety of the text and graphics presented in this information. Please contact our Technical Support if you have any questions.