

Current Transducer HAX 500 ... 2500-S

For the electronic measurement of currents: DC, AC, pulsed..., with galvanic separation between the primary circuit and the secondary circuit.

$$I_{PN} = 500 \dots 2500 \text{ A}$$

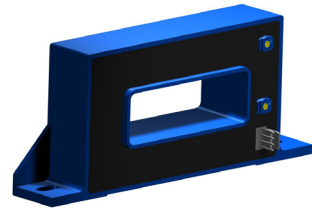

Electrical data

Type	Primary nominal rms current I_{PN} (A)	Primary current, measuring range ¹⁾ I_{PM} (A)	
HAX 500-S	500	±1500	
HAX 600-S	600	±1800	
HAX 850-S	850	±2550	
HAX 1000-S	1000	±3000	
HAX 1500-S	1500	±4500	
HAX 2000-S	2000	±5500	
HAX 2500-S	2500	±5500	
U_C	Supply voltage (±5 %) ¹⁾	±15	V
I_C	Current consumption	< +20/-15	mA
I_P	Overload capability	30000	At
R_{IS}	Insulation resistance @ 500 V DC	> 1000	MΩ
V_{out}	Output voltage (Analog) @ ± I_{PN} , $R_L = 10 \text{ k}\Omega$, $T_A = 25 \text{ }^\circ\text{C}$	±4	V
R_{out}	Output internal resistance	appr. 100	Ω
R_L	Load resistance	> 1	kΩ

Accuracy - Dynamic performance data

X	Accuracy @ I_{PN} , $T_A = 25 \text{ }^\circ\text{C}$ (excluding offset)	< ±1	% of I_{PN}
ϵ_L	Linearity error ²⁾ (0 ... ± I_{PN})	< ±1	% of I_{PN}
V_{OE}	Electrical offset voltage @ $T_A = 25 \text{ }^\circ\text{C}$	< ±20	mV
V_{OH}	Hysteresis offset voltage @ $I_P = 0$, after an excursion of $1 \times I_{PN}$	< ±30	mV
TCV_{OE}	Temperature coefficient of V_{OE}	< ±1	mV/K
TCV_{out}	Temperature coefficient of V_{out} (% of reading)	< ±0.1	%/K
t_r	Step response time to 90 % of I_{PN} ³⁾	< 5	μs
BW	Frequency bandwidth (-3 dB) ⁴⁾	DC ... 25	kHz

General data

T_A	Ambient operating temperature	-25 ... +85	°C
T_S	Ambient storage temperature	-25 ... +85	°C
m	Mass	appr. 450	g
	Standards	EN 50178: 1997 UL 508: 2013	

Notes: ¹⁾ Operating at $\pm 12 \text{ V} < U_C < \pm 15 \text{ V}$ will reduce the measuring range

²⁾ Linearity data exclude the electrical offset

³⁾ For a $di/dt > 50 \text{ A}/\mu\text{s}$

⁴⁾ Please refer to derating curves in the technical file to avoid excessive core heating at high frequency

⁵⁾ Variation of the offset during the test IEC 61000-4-3 between 100 to 200 MHz: 8 % of I_{SN} .

Features

- Hall effect measuring principle
- Insulating plastic case recognized according to UL 94-V0.

Advantages

- Low insertion losses
- Easy installation
- Low power consumption
- Small size and space saving
- Only one design for wide current ratings range
- High immunity to external interference.

Applications

- AC variable speed drives and servo motor drives
- Static converters for DC motor drivers
- Battery supplied applications
- Uninterruptible Power Supplies (UPS)
- Switched Mode Power Supplies (SMPS)
- Power suppliers for welding applications.

Application domain

- Industrial.

Current Transducer HAX 500 ... 2500-S

Insulation coordination

U_d	Rms voltage for AC insulation test, 50 Hz, 1 min	5	kV
\hat{U}_W	Impulse withstand voltage 1.2/50 μ s	8.3	kV
U_e	Partial discharge extinction rms voltage @ 10 pC	> 660	V
		Min	
d_{cp}	Creepage distance	15.7	mm
d_{cl}	Clearance	12.7	mm
CTI	Comparative tracking index (group IIIa)	275	

Applications examples

According to EN 50178 and IEC 61010-1 standards and following conditions:

- Over voltage category OV 3
- Pollution degree PD2
- Non-uniform field

	EN 50178	IEC 61010-1
$d_{cp}, d_{cl}, \hat{U}_W$	Rated insulation voltage	Nominal voltage
Basic insulation	1500 V	1000 V
Reinforced insulation	600 V	600 V

Safety

This transducer must be used in limited-energy secondary circuits according to IEC 61010-1.



This transducer must be used in electric/electronic equipment with respect to applicable standards and safety requirements in accordance with the manufacturer's operating instructions.



Caution, risk of electrical shock

When operating the transducer, certain parts of the module can carry hazardous voltage (eg. primary busbar, power supply).

Ignoring this warning can lead to injury and/or cause serious damage.

This transducer is a build-in device, whose conducting parts must be inaccessible after installation.

A protective housing or additional shield could be used.

Main supply must be able to be disconnected.

Dimensions HAX 500 ... 2500-S (in mm)

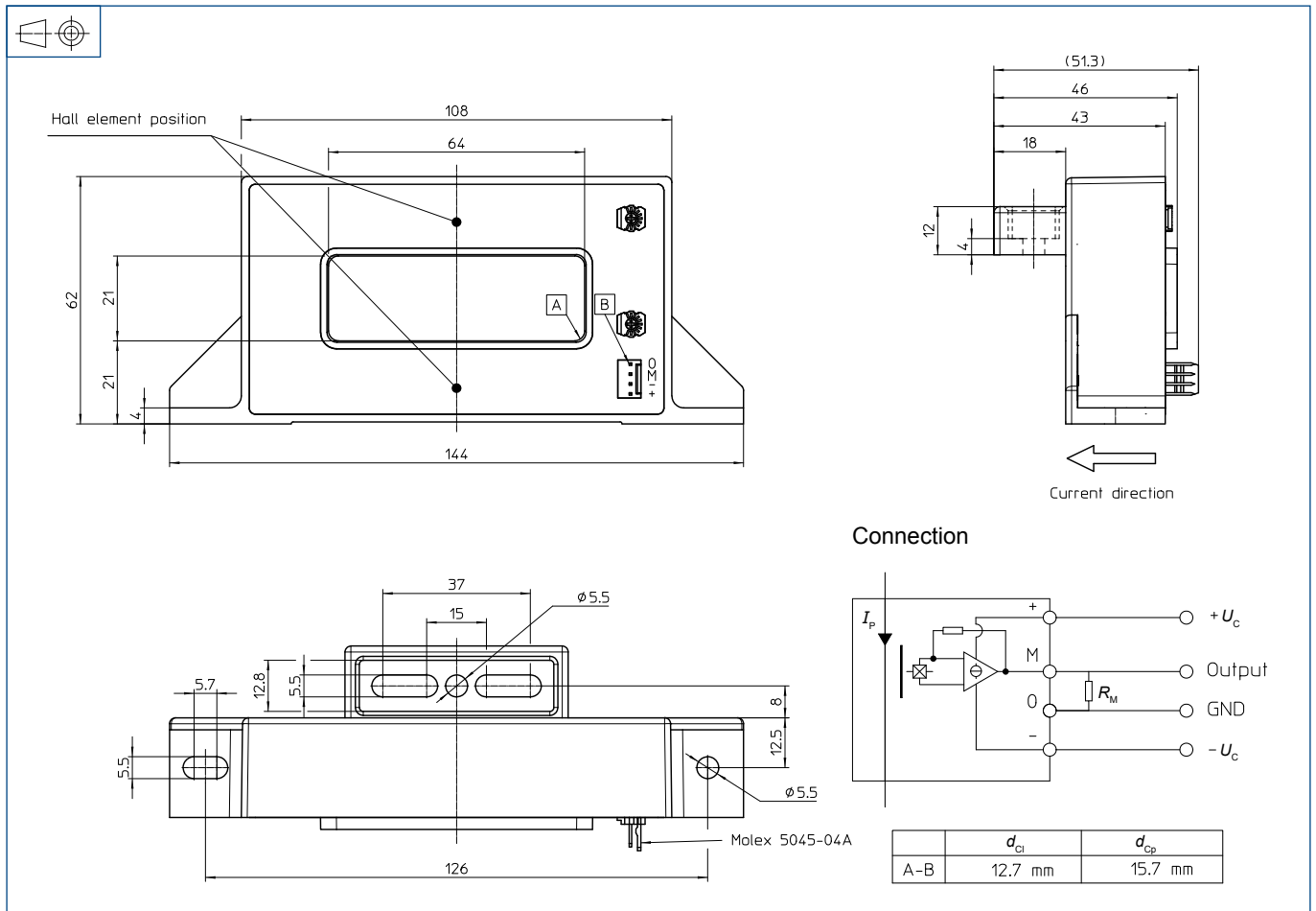

Mechanical characteristics

- General tolerance ± 1 mm
- Transducer fastening
 - 1 hole and 1 notch $\varnothing 5.5$ mm
 - 2 M5 steel screws
- Recommended fastening torque 1.5 N·m
- or
 - 1 hole and 2 notches $\varnothing 5.5$ mm
 - 3 M5 steel screws
- Recommended fastening torque 1.5 N·m
- Primary through-hole 64 × 21 mm
- Connection of secondary Molex 5045-04A

Remarks

- V_{out} is positive when I_p flows in the direction of the arrow.
- Temperature of the primary conductor should not exceed 100 °C.
- Installation of the transducer must be done unless otherwise specified on the datasheet, according to LEM Transducer Generic Mounting Rules. Please refer to LEM document N°ANE120504 available on our Web site: [Products/Product Documentation](#).
- Dynamic performances (di/dt and response time) are best with a single bar completely filling the primary hole.
- This is a standard model. For different versions (supply voltages, turns ratios, unidirectional measurements...), please contact us.