

Anybus[®] Communicator[™]

Modbus TCP[®] to Modbus RTU

STARTUP GUIDE

SP2860 1.0 en-US ENGLISH



Important User Information

Disclaimer

The information in this document is for informational purposes only. Please inform HMS Networks of any inaccuracies or omissions found in this document. HMS Networks disclaims any responsibility or liability for any errors that may appear in this document.

HMS Networks reserves the right to modify its products in line with its policy of continuous product development. The information in this document shall therefore not be construed as a commitment on the part of HMS Networks and is subject to change without notice. HMS Networks makes no commitment to update or keep current the information in this document.

The data, examples and illustrations found in this document are included for illustrative purposes and are only intended to help improve understanding of the functionality and handling of the product. In view of the wide range of possible applications of the product, and because of the many variables and requirements associated with any particular implementation, HMS Networks cannot assume responsibility or liability for actual use based on the data, examples or illustrations included in this document nor for any damages incurred during installation of the product. Those responsible for the use of the product must acquire sufficient knowledge in order to ensure that the product is used correctly in their specific application and that the application meets all performance and safety requirements including any applicable laws, regulations, codes and standards. Further, HMS Networks will under no circumstances assume liability or responsibility for any problems that may arise as a result from the use of undocumented features or functional side effects found outside the documented scope of the product. The effects caused by any direct or indirect use of such aspects of the product are undefined and may include e.g. compatibility issues and stability issues.

1 Preface

1.1 About This Document

This manual describes the installation of Anybus Communicator. For information on how to configure the Anybus Communicator, refer to the user manual.

For additional documentation and software downloads, FAQs, troubleshooting guides and technical support, please visit www.anybus.com/support.

1.2 Document Conventions

Numbered lists indicate tasks that should be carried out in sequence:

1. First do this
2. Then do this

Bulleted lists are used for:

- Tasks that can be carried out in any order
- Itemized information
- ▶ An action
 - and a result

User interaction elements (buttons etc.) are indicated with bold text.

```
Program code and script examples
```

Cross-reference within this document: [Document Conventions, p. 4](#)

External link (URL): www.hms-networks.com



WARNING

Instruction that must be followed to avoid a risk of death or serious injury.



Caution

Instruction that must be followed to avoid a risk of personal injury.



Instruction that must be followed to avoid a risk of reduced functionality and/or damage to the equipment, or to avoid a network security risk.



Additional information which may facilitate installation and/or operation.

1.3 Trademarks

Anybus® is a registered trademark of HMS Networks AB.

All other trademarks are the property of their respective holders.

2 Safety

2.1 Intended Use

The intended use of this equipment is as a communication interface and gateway.

The equipment receives and transmits data on various physical layers and connection types.

If this equipment is used in a manner not specified by the manufacturer, the protection provided by the equipment may be impaired.

2.2 General Safety

**Caution**

Ensure that the power supply is turned off before connecting it to the equipment.

**Caution**

This equipment contains parts that can be damaged by electrostatic discharge (ESD). Use ESD prevention measures to avoid damage.

**Caution**

To avoid system damage, the equipment should be connected to ground.



Using the wrong type of power supply can damage the equipment. Ensure that the power supply is connected properly and of the recommended type.

3 Preparation

3.1 Cabling

Have the following cables available:

- **Ethernet cable for configuration**
- **Ethernet cable for connecting to the high level network**
- **Power cable**

3.2 Tools

Have the following tools available:

- **Flat-head screwdriver, size 5.5 mm**
Needed when removing the Communicator from *DIN-rail*.
- **Flat-head screwdriver, size 3 mm**
Needed when connecting the cables to the *7-pin connector*.

3.3 Support and Resources



For additional documentation and software downloads, FAQs, troubleshooting guides and technical support, please **scan the QR code to visit the Communicator support web page.**

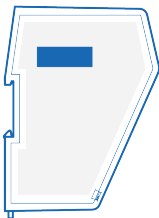

You can also visit www.anybus.com/support and enter the *product article number* to search for the Communicator support web page.

You find the *product article number* on the product cover.

4 Installation

4.1 DIN Rail Mounting



The equipment must be electrically grounded through the DIN rail for EMC compliance. Make sure that the equipment is correctly mounted on the rail and that the rail is properly grounded.

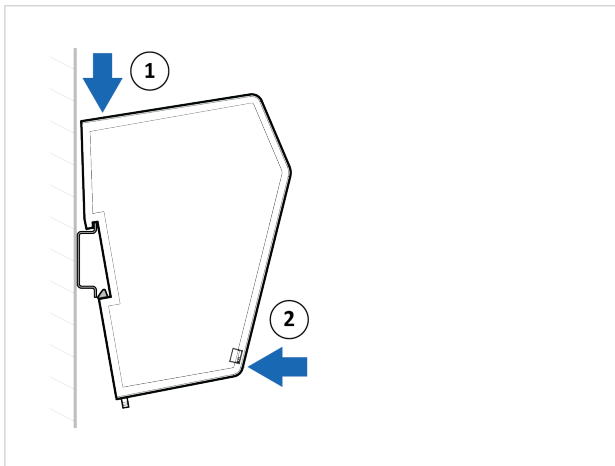

Attach the Communicator on the DIN rail.

4.2 Connecting to Modbus TCP Network

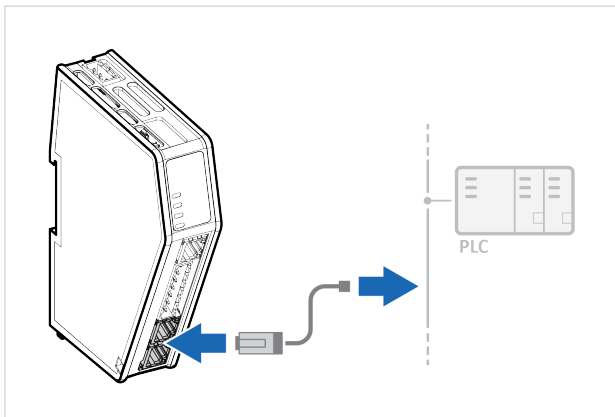

Modbus TCP Connector

	Pin	Description
	1	TD+
	2	TD-
	3	RD+
	4	
	5	
	6	RD-
	7	
	8	

4.3 Connecting to Serial RS232/RS485 Subnetwork



Use minimum 90 μ C copper (Cu) wire only.

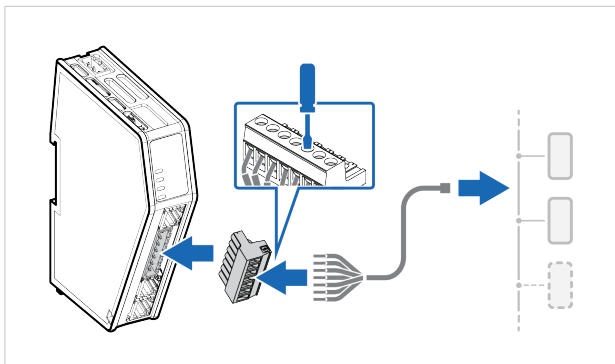

7-pin connector

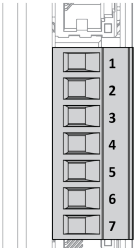
	Pin	Signal
	1	+5 V OUT
	2	RS485- A
	3	RS485+ B
	4	Signal GND
	5	Functional Earth (FE)
	6	RS232 Tx Output
	7	RS232 Rx Input

4.4 Connecting to Power



Caution

Ensure that the power supply is turned off before connecting it to the equipment.



Using the wrong type of power supply can damage the equipment. Ensure that the power supply is connected properly and of the recommended type.

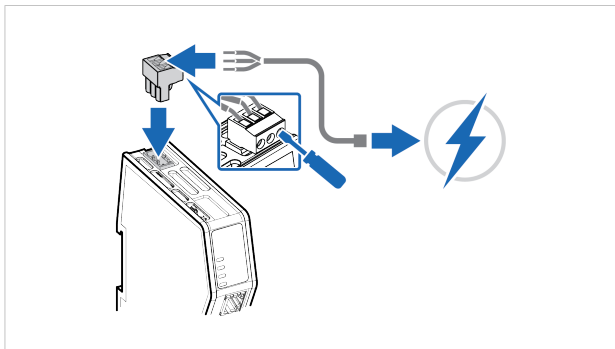

Power port

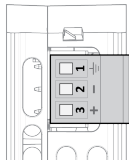

Pin	Description
1	Functional Earth (FE)
2	Ground (GND)
3	12-30 VDC Power Connector

4.5 Security Switch



After completing the configuration of the Communicator, lock the security switch to prevent unauthorized access to the Communicator built-in web interface.

When the *security switch* is in its locked position, the Communicator built-in web interface can not be accessed and the Communicator can not be configured. Network specific parameters, configured via the PLC is still available.

To Lock and Unlock the Security Switch

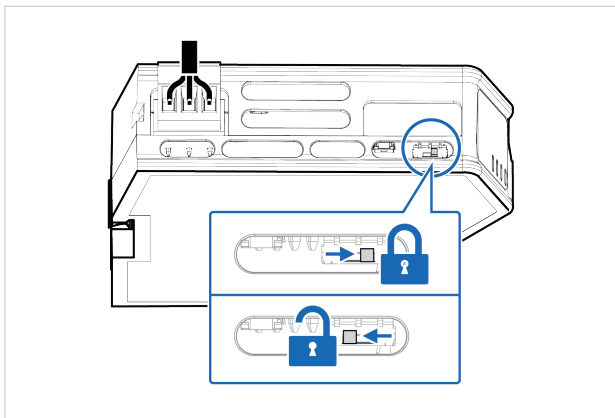

Use a pointed object, such as a ballpoint pen.

- To **lock** the security switch, push the toggle towards the **Communicator front**.
- To **unlock** the security switch, push the toggle towards the **Communicator back**.

Security Switch Status LED

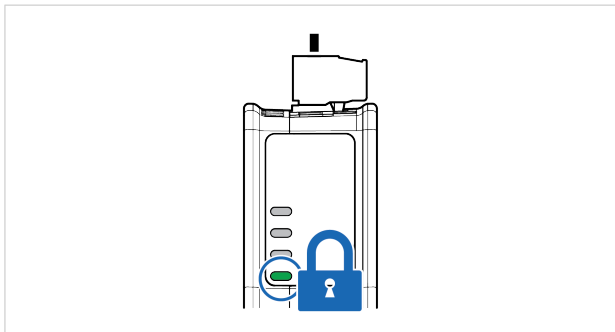

When the security switch is in its:

- locked position, the security switch status LED turn solid green.
- unlocked position, the security switch status LED is turned off.

4.6 Locking the Cables

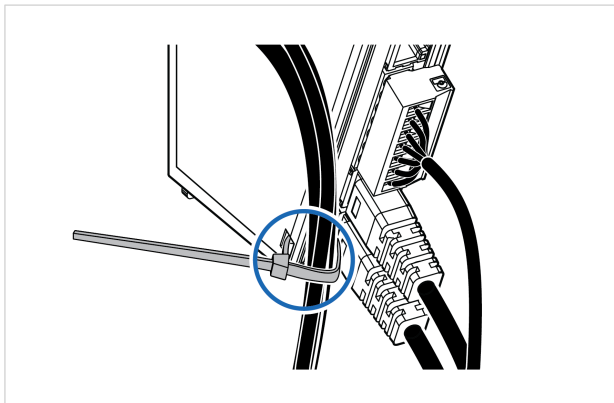

To strain relieve the cables, place a cable tie in the holder and lock the cables.

4.7 DIN Rail Demount

Before You Begin



Be careful when removing the Communicator from the DIN-rail. If not removed properly, the DIN rail locking mechanism and the product cover can break.

Have a flat-blade screwdriver, size 5.5 mm, available.

Procedure

Remove the Communicator from the DIN Rail:

1. Insert the screwdriver into the Communicator *DIN rail locking mechanism*.
2. To unlock the Communicator *DIN rail locking mechanism*, turn the screwdriver clockwise.

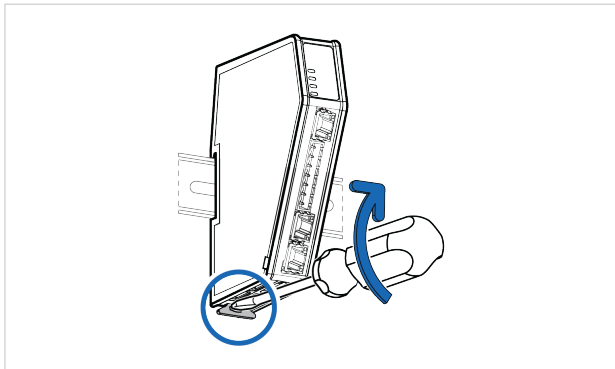

3. Hold the screwdriver in the *DIN rail locking mechanism* while you unhook the Communicator from the DIN rail.

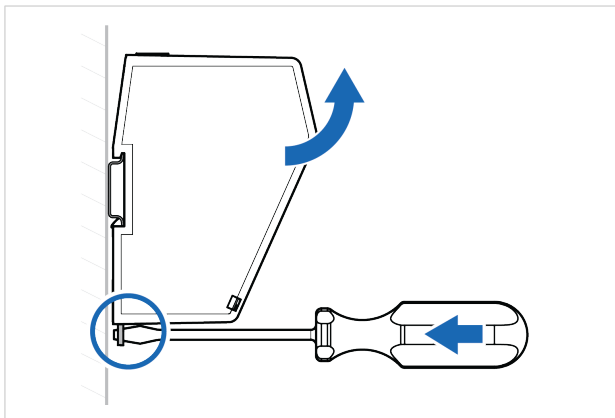

5 Configuration

5.1 Connecting to PC and power

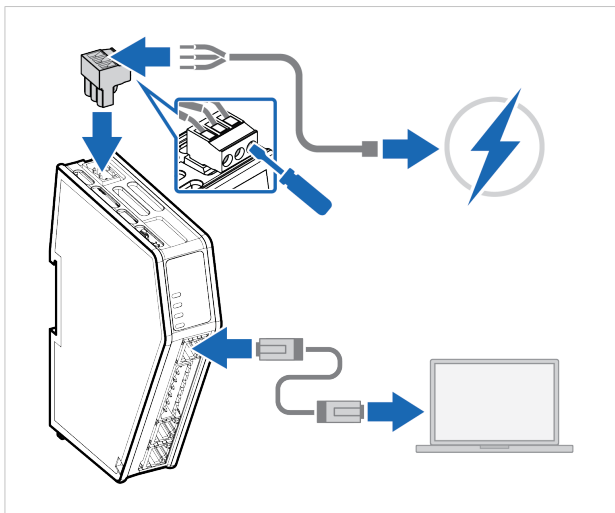

1. Connect an *Ethernet cable* between the *Communicator configuration port* and your PC.
2. Connect the Communicator to a power supply.

5.2 Finding the Communicator on Your PC

The Communicator default IP address is **192.168.0.10**.

To be able to access the Communicator built-in web interface:

Option 1 | Set a static IP address on the PC



On the PC accessing the Communicator built-in web interface, set a static IP address within the same IP address range as the Communicator IP address.

To access the Communicator built-in web interface, ensure that port Port 80 TCP is open in your PC Windows Firewall.

Note that when you change to a static IP address on your PC, internet access is lost.

Option 2 | Change the IP address on the Communicator configuration port



Use the software application HMS IPconfig to find and change the IP address on the Communicator configuration port, to one within the same IP address range as the PC accessing the Communicator built-in web interface.

To download the installation files, please visit www.anybus.com/support and enter the *product article number* to search for the Communicator support web page. You find the *product article number* on the product cover.

5.3 Configuring the Communicator

The screenshot displays the Anybus Communicator web interface. On the left is a navigation sidebar with sections for Home, Configuration, Maintenance, and Troubleshooting. The main area shows the status of three communication protocols: Modbus TCP (in progress), Anybus Communicator (initial state), and Serial RS-232/485 (ready for initialization). A 'New node' notification is visible at the bottom right.

Open the Communicator built-in web interface in HMS IPconfig or enter the Communicator IP address in your web browser.

The built-in web interface takes you through the steps to configure the Communicator.

Support and Resources

If you need more in-depth information about the configuration, please visit www.anybus.com/support and enter the *product article number* to search for the Communicator support web page. You find the *product article number* on the product cover.

6 Technical Data

6.1 Technical Specifications

Article identification	ABC3028-A
Communication connector	RJ45 x 2
Configuration connector	RJ45
Serial connector	7-pin screw connector
Power connector	3-pin screw connector
Power supply	12-30 VDC Reverse voltage protection and short circuit protection
Power consumption	Typical: 160 mA @ 24 V Max: 400 mA @ 12 V
Storage temperature	-40 to +85 °C
Operating temperature	-25 to +70 °C
Humidity	EN 60068-2-78: Damp heat, +40°C, 93% humidity for 4 days EN 60068-2-30: Damp heat, +25°C – +55°C, 95% RH, 2 cycles
Vibration	See datasheet
Housing material	Plastic See datasheet for details
Protection class	IP20
Product weight	150 g
Dimensions	27 x 144 x 98 mm (H x W x D) with connectors included
Mounting	DIN-rail

Additional technical data and information related to the installation and use of this product can be found at www.anybus.com/support.

This page intentionally left blank

A Communicator LED Indicators



Before you can verify operation you must configure the Communicator.

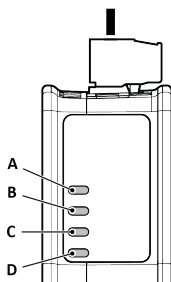

	LED A	LED B	LED C	LED D
Operation Status	Gateway status	Modbus TCP Server	Subnetwork	Security switch
Off	No power	No power/ Exception/No Modbus TCP IP address	No power/ Exception/ Subnetwork not running	No power/ Security switch is unlocked/ Exception/Fatal error
Green, flashing	Startup phase	Modbus TCP online, no messages received.	Running, one or more nodes are offline	N/A
Green	Operational	Modbus TCP online, at least one message received.	Running	Security switch is locked

	LED A	LED B	LED C	LED D
Operation Status	Gateway status	Modbus TCP Server	Subnetwork	Security switch
Red	Exception/ Fatal error	IP address conflict detected, or Fatal error.	Fatal error	N/A
Red, flashing	Invalid configura- tion	Connection timeout.	All nodes are offline	N/A
Green/Red, flashing	Power up self-test/ Firmware update/ Firmware recovery	N/A	N/A	N/A

B Modbus TCP LED Indicators

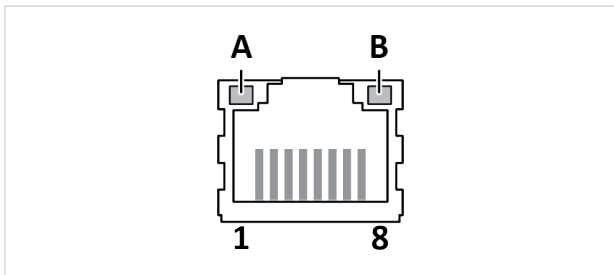

LED A	Function
Off	No link (or no power)
Green	Link (100 Mbit/s) established
Green, flashing	Activity (100 Mbit/s)
Yellow	Link (10 Mbit/s) established
Yellow, flashing	Activity (10 Mbit/s)

LED B	Function
Off	Not used

© 2020 HMS Industrial Networks
Box 4126
300 04 Halmstad, Sweden

info@hms.se

SP2860 1.0 en-US / 2020-09-14 / 19825