



SPECTRACOOOL
SLIM FIT AIR CONDITIONERS
ALL MODELS

INSTRUCTION MANUAL

DESIGN WITH CONFIDENCE

TABLE OF CONTENTS

Pentair Cooling Sales and Service Contacts	4
Warranty and Return Policy	4
General Information	5
Standards, CE, Declaration of Conformity	5
Receiving The Air Conditioner	6
Handling and Testing The Air Conditioner	6
PHASE MONITOR (460v Only)	6
How to Read Model Numbers	6
General Safety Information	7
General Technical Information	7
Sequence of Operation	7
Cooling	7
Component Operation	7
Smart Controller (General Alarms)	7
Remote Access Control (Optional)	7
Door Switch	7
Active Condensate Management	7
Mounting	8
Tools Required For Installation:	8
External Mounting	8
Partial Recessed Mounting (Not Applicable to 300W Unit)	8
Full Recessed Mounting	10
Electrical Installation	11
Principles of Operation	11
Smart Controller	12
Introduction	12
Energizing The Controller	12
Control Status Indication	12
Displaying and Changing Program Variables	13
Models with °C Controller	13
Operating Parameters	13
Alarm Parameters	13
Models with °F Controller	13
Operating Parameters	13
Alarm Parameters	13
Operating Real-Time Clock (RTC) Parameters	13
Displaying Temperature Sensors	14
Compressor Restart Time Delay	14
Alarm Output Contact	14
Alarm Input Connection	14
Alarm Condition Display	15
Master/Slave Capability (Optional)	16
Master/Slave Operating Parameters	16
Alarm Input Connection	17
Master/Slave Wiring	17
Remote Access Control	18
Air Conditioner Unit Communication Features (Optional)	18
USB Communication	18
Ethernet Communication	18
Master/Slave Capability (Optional)	19
Master/Slave with Remote Access	19
Software and Configuration File Downloads	19
Remote Access Control Pin-out	20
Technical Information	22
S06 Models 300/500W	22
S06 Schematic 300/500W	22
S06 Wire Diagram 300/500W	23
S06 Dimensional Drawings	24
300W	24
500W	24
S06 Installation Instruction	25
S06 300W Cutout Drawing	25
Surface Mount	25
Full Recess Mount	25
S06 500W Cutout Drawing	26
Surface Mount	26
Partial and Full Recess Mount	26

S06 Unit Characteristics	27
S06 Components	28
S10 Models 1000/1500W	29
S10 Schematics	29
1000W 115V, 230V	29
1000W 460V	29
1500W 115V	30
1500W 230V	30
1500W 460V	31
S10 Wire Diagrams	32
1000W 115V, 230V	32
1000W 460V	33
1500W 115V	34
1500W 230V	35
1500W 460V	36
S10 Dimensional Drawing	37
1000/1500W	37
S10 Installation Instruction	38
S10 1000/1500W Cutout Drawing	38
Surface Mount	38
Partial and Full Recess Mount	38
S10 Unit Characteristics (115V, 230V)	39
S10 Unit Characteristics (460V)	40
S10 Components (1 Phase)	41
S10 Components (3 pHASE)	42
S16 Models 2000/2500W	43
S16 Schematics	43
2000W 115V	43
2000W 230V	43
2000W 460V	44
2500W 115V	44
2500W 230V	45
2500W 460V	45
4000W 460V	46
S16 Wire Diagrams	47
2000W 115V	47
2000W 230V	48
2000W 460V	49
2500W 115V	50
2500W 230V	51
2500W 460V	52
4000W 460V	53
S16 Dimensional Drawing	54
2000/2500W	54
4000W	55
S16 Installation Instruction	56
S16 2000/2500W Cutout Drawing	56
Surface Mount	56
Partial and Full Recess Mount	56
S16 4000W Cutout Drawing	57
Surface Mount	57
Partial Recess Mount	57
S16 Unit Characteristics (115V, 230V)	58
S16 Unit Characteristics (460V)	59
S16 Components (115V, 230V)	60
S16 Components (460V)	61
Maintenance	62
Compressor	62
Inlet Air Filter (Field Installed Option)	62
How To Remove, Clean or Install an optional Inlet Air Filter	62
Condenser and Evaporator Air Movers	62
Maintenance / Inspection Recommendations	63
Basic Air Conditioning Trouble Shooting Check List - Remote Access Control Version	64
Basic Air Conditioning Trouble Shooting Checklist	65
3-Phase Basic Air Conditioning Trouble Shooting Check List - Remote Access Control Version	66
3-Phase Symptoms and Possible Causes - Remote Access Control Version	67

PENTAIR COOLING SALES AND SERVICE CONTACTS

EUROPE:	
Deutschland (Germany)	+49 (0) 7082 794 0
France	+33 (0) 3 88 90 64 90
Italia (Italy)	+39 02 932 714-1
Polska (Poland)	+48 22 209 98 37
Россия (Russia)	+7 495 926 18 85
Sverige (Sweden)	+46 (0) 8 683 6100
United Kingdom	+44 (0) 1442 240 471
MIDDLE EAST:	
UAE	+971 4 378 1700
NORTH AMERICA:	
México	+52 555 280 1449
US and Canada	+1 763 421 2240
SOUTH AMERICA:	
Brasil (Brazil)	+55 15 3363 9100
ASIA/SOUTH PACIFIC:	
中国 (China)	+86 400 820 1133
India	+91 80 2845 4640
日本 (Japan)	+81 (0) 45 476 02 81
Singapore	+65 6768 5800

Or visit PentairProtect.com

WARRANTY AND RETURN POLICY

Visit www.pentairprotect.com/en/hoffman/warranty-information for Product warranty and return policy.

GENERAL INFORMATION STANDARDS, CE, DECLARATION OF CONFORMITY



PENTAIR TECHNICAL SOLUTIONS
2100 Hoffman Way
Minneapolis, MN 55303-1745, USA
+1.763.421.2240 main

Declaration of Conformity

Issued by Manufacturer

Pentair Technical Products China dba Hoffman
Air Port Industrial Zone
Shuangyuan Road South
Chengyang District
Qingdao,
Shandong 266108 China

declare at our sole responsibility, that these devices are designed and constructed according to the fundamental safety and health requirements of the relevant EC directives.

Equipment Description: S0603X6GXXX, S0605X6GXXX, S1010X6GXXX, S1015X6GXXX, S1620X6GXXX, S1625X6GXXX, S1640X6GXXX

Product Name: "SpectraCool SLIM Fit" Control Cabinet Air-Conditioner
First Year of CE Marking: 2014

Ingress Protection: IP 34 – Ambient Side, IP 54 Enclosure Side

Applicable Directives: Directive /95/EC Low Voltage Directive
Laws for electrical equipment within certain voltage limits
Directive /108/EC EMC Directive relating to
Electromagnetic compatibility
Directive /65/EU on the restriction of the use of certain hazardous substances in
electrical and electronic equipment

Applicable Standards: EN 378-1 and -2 Refrigerating systems and heat pumps-safety and environmental requirements
EN 12100-1 and -2 Safety of machinery, equipment and facilities
EN ISO 13857 Safety of machinery-safety distances to prevent hazard zones being reached by upper and lower limbs
EN 60335-1 and -2-40 Appliances-Safety, Particular requirements for electrical heat pumps, air-conditioners and dehumidifiers
DIN EN 14511-2 (4) Air conditioner, Test conditions
DIN EN 14511-3 (4) Air Conditioner, Test methods
DIN EN 14511-4 (4.2, 4.5, 4.6) Air Conditioner, operating requirements
DIN 3168-4.5 Coolers for distribution boxes, concepts testing, marking
EN 61000-6-2 Electromagnetic compatibility (EMC)- Part 6-2: Generic standards - Immunity for industrial environments
EN 61000-6-3 Electromagnetic compatibility (EMC)- Part 6-3: Generic standards – Emission standard for residential, commercial, and light industrial environments
EN 60529, IEC 60529 Degrees of protection provided by enclosures (IP code)
EN 50581: Technical documentation for the assessment of electrical and electronic products with respect to the restriction of hazardous substances
DIN 45635 Measurement of noise emitted by machines, airborne noise emission

For official DoC, go to <http://www.pentairprotect.com/en/na/Compliance>

Authorized by:

7/15/2014

Tom Hurney

Date

Manager, Lab & Certifications

Subject to Change Without Notice

DOC: 00001 -A

RECEIVING THE AIR CONDITIONER

Inspect the air conditioner. Check for concealed damage that may have occurred during shipment. Look for dents, scratches, loose assemblies, evidence of oil, etc. Damage evident upon receipt should be noted on the freight bill. Damage should be brought to the attention of the delivering carrier -- NOT to Pentair Equipment Protection -- within 15 days of delivery. Save the carton and packing material and request an inspection. Then file a claim with the delivering carrier.

Pentair Equipment Protection cannot accept responsibility for freight damages; however, we will assist you in any way possible.

HANDLING AND TESTING THE AIR CONDITIONER

If the air conditioner has been in a horizontal position, be certain it is placed in an upright, vertical or mounting position for a minimum of five (5) minutes before operating.

 CAUTION
Do not attempt to operate the air conditioner while it is horizontal or on its side, back or front. The refrigeration compressor is filled with lubricating oil. This will cause permanent damage to the air conditioner and also voids the warranty.

TEST FOR FUNCTIONALITY BEFORE MOUNTING THE AIR CONDITIONER TO THE ENCLOSURE.

Refer to the nameplate for proper electrical current requirements, and then wire the unit to a properly grounded power supply using copper conductors only. Power supply wiring should be restrained after field installation to ensure no contact with internal fan. Minimum circuit ampacity should be at least 125% of the amperage shown on the unit nameplate. No other equipment should be connected to this circuit to prevent overloading.

Electrical circuit should be fused with slow blow or heating, air conditioning and refrigeration (HACR) rated circuit breaker. Use a higher ampere rated circuit breaker or time-delay fuse that is closest to the nominal ampere rating of the air conditioner, or sum of the individual component ampere ratings, to protect system electrical circuits from short circuit or overload.

PHASE MONITOR (460V ONLY)

**Note Location: Rear access panel, D-shaped sight port.
Reference S10 Dimensional Drawing on page 37; S16 Dimensional Drawing, 2000/2500W on page 54; S16 Dimensional Drawing, 4000W on page 55**

This product is equipped with Phase/Voltage Protection. Please verify correct phasing and voltage before operating. Note the fans may still operate if phasing is incorrect, but the compressor will not, so the unit will not cool. Illuminated light on Phase Monitor indicates phase is correct.

If the light is not illuminated, disconnect power from the unit and swap any two power leads at the terminal block. This should correct the phasing. The light should now illuminate when power is reapplied.

Immediately after applying power, the evaporator blower (enclosure air) should start running. Operate the air conditioner with the compressor running for five (5) to ten (10) minutes. You will need to set the cooling controller setpoint below the ambient temperature to operate the compressor.

Condenser air temperatures should be warmer than normal room temperatures within a few minutes after the condenser impellers start.

See Sequence of Operation on page 7 for specifics on how the unit operates when powered up.

HOW TO READ MODEL NUMBERS

S10	15	2	6	G031
1	2	3	4	5

1. Identifies the type/family of air conditioner and the approximate height (i.e. S10 = Slim Fit family about 1000mm high (10x100).
2. This is the air conditioner's listed capacity in Watts at rated conditions. (i.e. 15=1500W (15x100) at 35/35 C)
3. 1 = 115 Volt, 2 = 230 Volt, 4 = 400/460 Volt.
4. 5 = 50 Hz only, 6 = 50/60 Hz or 60 Hz only.
5. Unique set of numbers for each air conditioner which identifies the accessories on a model.

GENERAL SAFETY INFORMATION

Please observe the following general safety instructions when assembling and operating the unit:

- Assembly, installation and servicing may only be performed by properly trained specialists.
- When transporting the enclosure with the cooling unit externally mounted, always use an additional shipping brace to support the cooling unit.

GENERAL TECHNICAL INFORMATION

The evaporator outlet sensor monitors the enclosure return air temperature to prevent ice buildup on the evaporator coil. If the air temperature drops below -1°C, the compressor and condenser air mover(s) shut off. They turn back on when the temperature rises above 15°C.

The compressor and the air movers are equipped with overload protection to guard against excess current and temperatures.

SEQUENCE OF OPERATION

The air conditioner comes standard with smart controller. During cooling modes, the evaporator fan will be running.

COOLING

When the enclosure temperature is above the cooling setpoint, power is applied to the compressor and condenser air mover(s).

Operating the air conditioner below the minimum ambient temperature or above the maximum ambient temperatures indicated on the nameplate voids all warranties. DO NOT adjust the setpoint to a temperature lower than 20°C. Doing so can increase the likelihood of frost buildup on the evaporator coil.

The moisture that the sealed enclosure air can contain is limited. If moisture flows from the drain tube continuously this can only mean that ambient air is entering the enclosure. Be aware that frequent opening of the enclosure's door admits humid air that the air conditioner must then dehumidify.

COMPONENT OPERATION

NOTE: Do not reduce the time delay setting on the controller to less than 120 seconds. This may cause the compressor to cycle too rapidly, shortening the life of the compressor.

SMART CONTROLLER (GENERAL ALARMS)

See Smart Controller on page 12

REMOTE ACCESS CONTROL (OPTIONAL)

See Remote Access Control on page 18

DOOR SWITCH

If a door switch is available, connect it to the terminals marked WHT/DS1 and WHT/DS2. The switch circuit should be open when the door is closed, and closed when the door is open. Several door switches may be connected in parallel and operated on one cooling unit. The door switch only supports a floating connection with no external voltages.

ACTIVE CONDENSATE MANAGEMENT

At low temperatures and high humidity levels inside the enclosure, condensation may form on the evaporator coil.

Slim Fit air conditioners continuously evaporate the water that may be in the drain pan due to condensation from the evaporator coil into the external air stream. Excess condensate is routed downwards out of the air conditioner via a barbed fitting at the bottom of the condenser side of the unit. A 10 mm (.40) inside diameter tube can be attached to the fitting and routed to a nearby drain.

MOUNTING

TOOLS REQUIRED FOR INSTALLATION:

- #2 Phillips screwdriver
- 6.5 mm slotted screwdriver
- 13 mm wrench or socket

EXTERNAL MOUNTING

1. Using the mounting gasket kit provided with the unit, install gasket to the air conditioner, see Figure 1.
2. Screw the supplied grub screws into the blind nuts on the rear of the unit, see Figure 2.
3. Secure the unit to the enclosure using the supplied washers and nuts. Use caution to avoid damaging the gasket while positioning the unit.

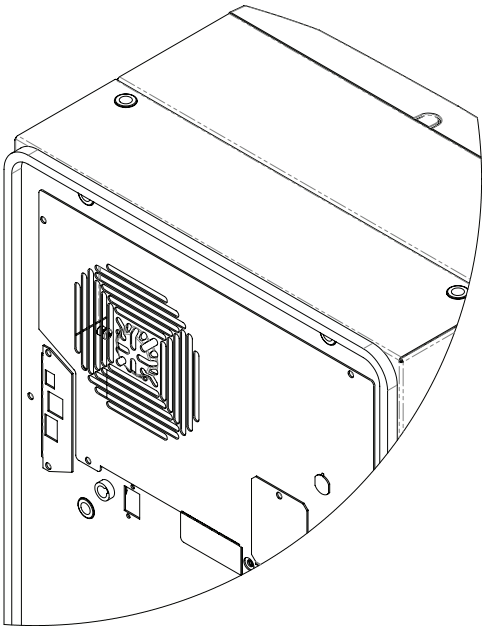

Figure 1

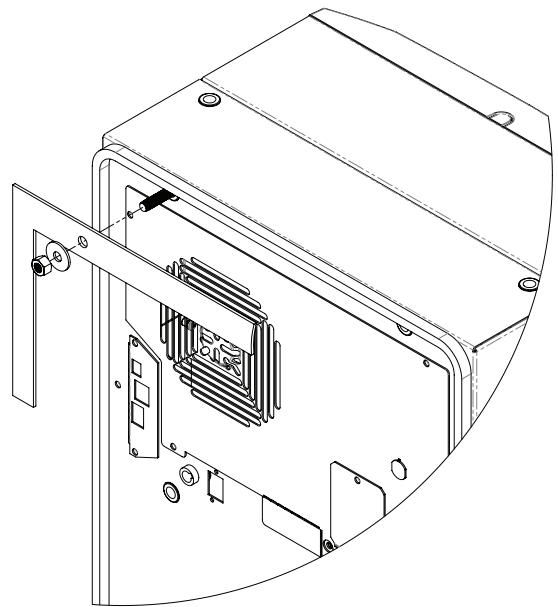

Figure 2

PARTIAL RECESSED MOUNTING (NOT APPLICABLE TO 300W UNIT)

1. Carefully remove the louvered grille, and where applicable, remove the center panel from the enclosure by pulling forwards. See Figure 3 on page 9.
2. Carefully disconnect the connectors from the rear of the smart controller.
3. Remove the two front screws.
4. Remove the four nuts on the front panel and pull the panel assembly forward approximately 5 cm. See Figure 4 on page 9.
5. Disconnect the fan electrical connection.
6. Remove the front panel.
7. Remove the four standoffs, leaving the grub screws in place.
8. Push the rear enclosure half into the mounting cutout and secure it with the four standoffs. See Figure 5 on page 9.
9. Push the smart controller cables through the rectangular hole in the front panel.
10. Reconnect the fan electrical connector.
11. Mount the front panel using the nuts removed in step 4.
12. Install two front screws.
13. Carefully reconnect the smart controller connectors .
14. Push the louvered grille and, where applicable, the center panel, onto the front panel. See Figure 6 on page 9.

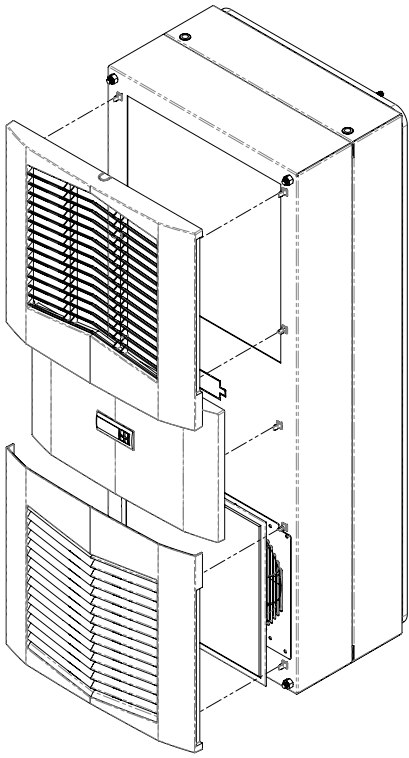

Figure 3

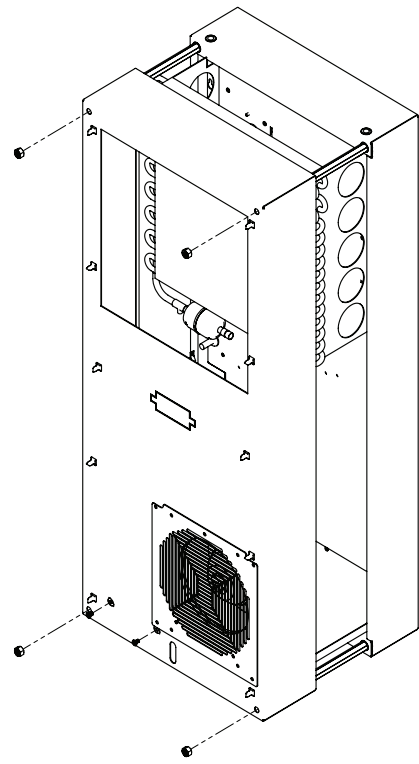

Figure 4

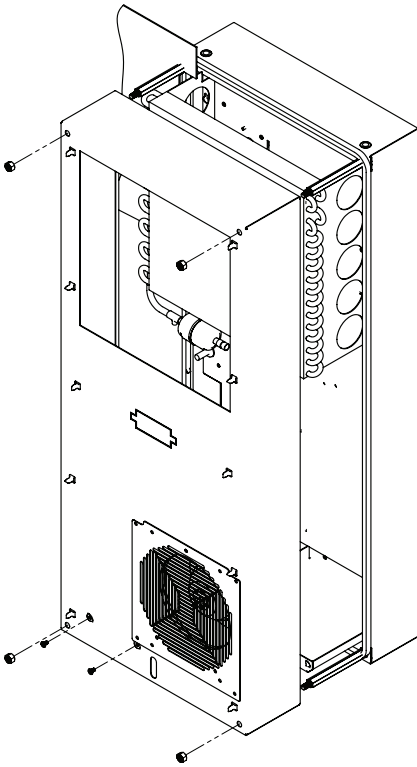

Figure 5

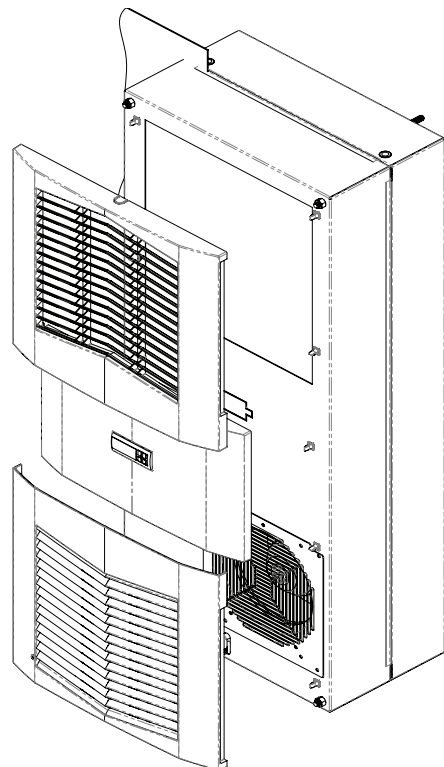

Figure 6

FULL RECESSED MOUNTING

1. Carefully remove the louvered grille, and where applicable, remove the center panel from the enclosure by pulling forwards.
2. Carefully disconnect the connectors from the rear of the smart controller.
3. Using the mounting gasket kit provided with the unit, install gasket to the air conditioner front panel. See Figure 7.
4. Remove the four nuts on the front panel.
5. Push the unit into the mounting cutout and secure it using the nuts removed in step 4.
6. Carefully reconnect the smart controller.
7. Push the louvered grille and, where applicable, the center panel, onto the front panel. See Figure 8.

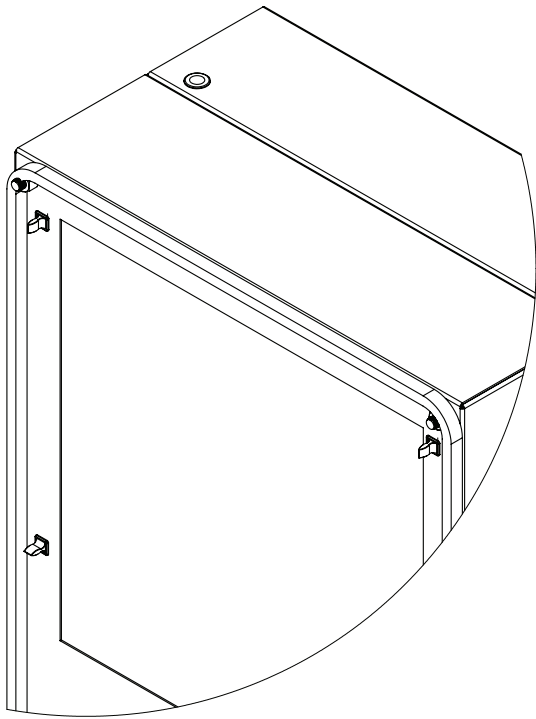

Figure 7

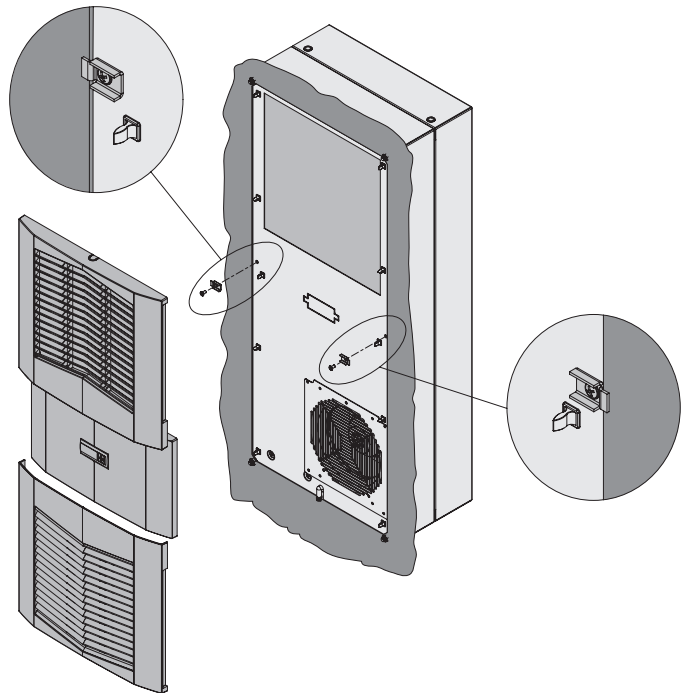

Figure 8

ELECTRICAL INSTALLATION

1. Loosen the screw on the evaporator access panel and remove the power access panel. See Figure 9.
2. Push the power supply wire through the strain relief.
3. Connect the wire to the terminal block per the label.
4. Reinstall the power access panel and screw.
5. Tighten the screw on the strain relief to secure the supply wire, see Figure 10.

NOTE: Use a higher ampere rated circuit breaker, or time-delay fuse, that is closest to the nominal ampere rating of the air conditioner, or sum of the individual component ampere ratings, to protect the system electrical circuits from short circuit or overload.

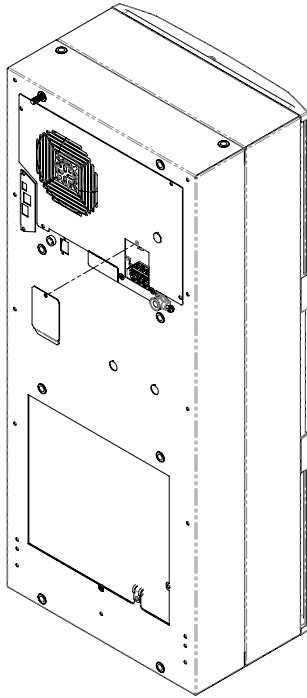

Figure 9

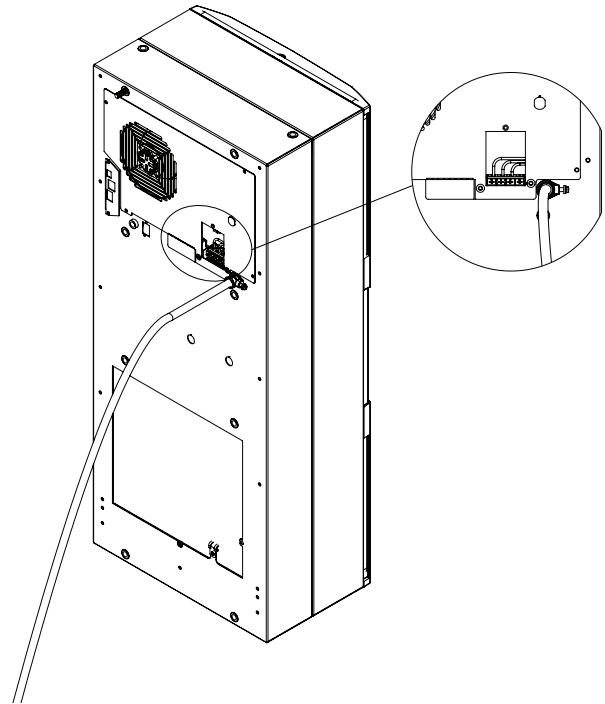

Figure 10

PRINCIPLES OF OPERATION

If electrical power to the air conditioner is interrupted and reapplied, the compressor may take up to five (5) minutes to restart due to the high back pressure of the compressor.

NOTE: The controller includes a nominal time delay setting of 5 minutes. Do not decrease the time delay setting to less than 2 minutes, as this may cause rapid cycling of the compressor, which may reduce the life of the compressor.

SMART CONTROLLER

INTRODUCTION

The smart controller is a parametric controller for the complete management of air conditioners. All settings are pre-programmed at the factory. Cooling setpoint, cooling differential, high/low temperature alarm setpoints, and door open and/or smoke detected switch can be adjusted by the user. Alarms are outputted through a relay contact.

NOTE: The polyester tape on the topside and the neoprene seal around the connectors assure IP34 rating protection for the controller. DO NOT REMOVE.

ENERGIZING THE CONTROLLER

The controller is wired and pre-programmed at the factory to be energizing when power is applied to the air conditioner. The controller will default to the standalone operating mode when initially powered on. Master/Slave operating mode is optional and will require additional setup.

CONTROL STATUS INDICATION

The display has numerous symbols that indicate if the controller is heating, cooling, alarming; if the compressor is enabled and if the ambient fan is enabled. The 3 alpha-numeric characters further describe alarms and show the cabinet temperature by default.

NOTE: The Slim Fit air conditioners DO NOT come standard with a heating option.

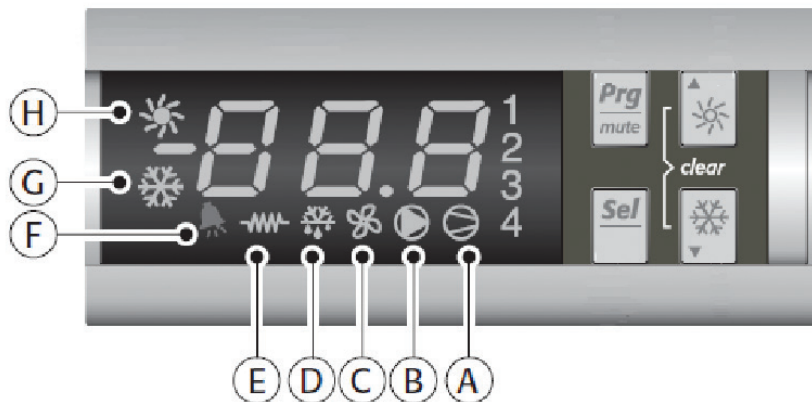

SYMBOL	COLOR	ICON ON	ICON FLASHING
1,2,3,4	AMBER	1. Compressor On 2. TLAN Device ID	1. Flashing at startup request in standalone mode. 2. Master/Slave Mode: 1: TLAN Master. 2,3,4: TLAN Slave. Device ID 2,3,4 are not active in standalone mode.
A	AMBER	Compressor On	Active when compressor is ON
B	AMBER	Evaporator Fan On	Active when evaporator fan is ON
C	AMBER	Not Used	Not used and always OFF
D	AMBER	Master Unit	Active when this is the TLAN Master
E	AMBER	Electric Heater	Not used (always OFF)
F	RED	Alarm Active	Active if there is an alarm condition
G	AMBER	Controller Active	ON indicates power and activates all functions. OFF indicates controller is in standby mode and all functions are OFF.
H	AMBER	Not Used	Not used (always OFF)

NOTE: On the smart controller, the display symbols for “H” and “E” are always OFF. If they turn ON, simply hold the ☀️ “sun” button greater than 5 seconds to turn OFF. The electric heater “E” symbol is required to minimize the heating setpoint (parameter A04) and/or defrost setpoint (parameter A01). Then, hold the ❄️ “Cooling” button greater than 5 seconds to turn ON the snowflake symbol (“G”).

DISPLAYING AND CHANGING PROGRAM VARIABLES

Access: To view and/or change parameters, press and hold the “Prg” and “Sel” buttons for greater than 5 seconds. Press the “up” or “down” arrow buttons until “22” is displayed, then press “Sel”. When “S-P” is displayed, press “Sel”.

Navigation: Press “up” or “down” arrow to display sub-menu, then press “Sel” to select the desired sub-menu. In the sub-menu, use “up” or “down” to display parameters for viewing or changing and press “Sel”. Use “Prg” button to back out or exit the menu levels as desired.

Adjust: Use the “up” or “down” arrow to change the parameter value, then press “Sel” button to save the setting. If the “Sel” button is NOT pressed, the updated setting will not be saved. Navigate to and change other parameters as desired. When finished, press “Prg” button to back out or exit the sub-menu to the main menu.

NOTE: The display will revert to normal temperature display mode if no buttons are pressed for 60 seconds.

MODELS WITH °C CONTROLLER

Cooling turns ON at r01 (setpoint) and OFF at r01 (setpoint) – r02 (differential).

For example, using default values from the table below, cooling will turn ON at 35 °C (setpoint) and turn OFF at 30 °C (setpoint – differential).

OPERATING PARAMETERS

Parameter	Description	Default Value	Range
r01	Cooling set-point	35°C	20°C to 55°C
r02	Cooling differential	5°C	-
P08	Door Open and/or smoke detected	28	4 or 28

ALARM PARAMETERS

Parameter	Description	Default Value	Range
P16	High Temperature Alarm	55°C	-
P19	Low Temperature Alarm	14°C	-

MODELS WITH °F CONTROLLER

Cooling turns ON at r01 (setpoint) + r02 (differential), and OFF at r01 (setpoint)

For example, using default values from the table below, cooling will turn ON at 87 °F (setpoint) + (differential), and turn OFF at 80 °F (setpoint).

OPERATING PARAMETERS

Parameter	Description	Default Value	Range
r01	Cooling set-point	80°F	72°F to 120°F
r02	Cooling differential	7°F	-
P08	Door Open and/or smoke detected	28	4 or 28

ALARM PARAMETERS

Parameter	Description	Default Value	Range
P16	High Temperature Alarm	125°F	-
P19	Low Temperature Alarm	40°F	-

OPERATING REAL-TIME CLOCK (RTC) PARAMETERS

Parameter	Description	Default Value	Range
t01	Hour	0	0 to 23
t02	Minute	0	0 to 59
t03	Day	0	1 to 31
t04	Month	0	1 to 12
t05	Year	0	6 to 99

DISPLAYING TEMPERATURE SENSORS

Both the air inlet sensor (b01) and outlet or evaporator coil sensor (b02), can be viewed at any time by pressing the “up” or “down” arrow button on the front panel of the controller display. The display will revert to the temperature sensor number b01 (air inlet temperature) or b02 (air outlet temperature) after 60 seconds. Both sensors can also be read through the Ethernet and USB connections with the optional remote access communication board.

COMPRESSOR RESTART TIME DELAY

A factory set 5-minute (300 second) restart delay exists to reduce residual back pressure before allowing the compressor to restart. The compressor will stay OFF for the entire restart duration after the compressor is disabled. A flashing 1 on the controller display will indicate the unit is in a compressor restart delay while calling for cooling. If the time delay is reduced to less than 5 minutes, this may cause reduced compressor life.

ALARM OUTPUT CONTACT

The smart controller has a normally open dry contact alarm output with a resistive load rating of 250 VAC to 3 Amp. The 6-POS connector terminals 3 and 4 (marked YEL/ALARM) located on the enclosure side of the unit provides connection to this output.

ALARM INPUT CONNECTION

The smart controller can accept a dry contact/switch input via the 6-POS connector terminals 1 and 2 (marked WHT/DS1 and WHT/DS2), located on the enclosure side of the unit. This input is associated with the controller display alarm mnemonic “tP” (door open and/or smoke detected). Note that the door open and/or smoke detected is pre-programmed at the factory as “Normally Open”.

To use the door open and/or smoke detected feature, simply connect the customer supplied wires from the enclosure door switch to DS1 and DS2.

ALARM CONDITION DISPLAY

There are eleven possible on-latching alarm conditions detectable by the controller that are indicated on the controller display. All alarms can also be accessed through the Ethernet and USB connections with the optional remote access communication board.

Alarm Mnemonic	Description	Cause	Result	Alarm Relay
tP	General Alarm	Door open and/or smoke detected	Unit turns off for duration of alarm	Relay Contact Closed
LA	High Pressure Warning	MALF high pressure switch opens (See Note 3 below)	No effect on function	N/A
LP	Low Pressure Alarm	Low pressure switch open (see note 4 below)	No effect on function	Relay Contact Closed
E1	Air Inlet Temperature Sensor Alarm	Sensor Failure	See Note 1 below	Relay Contact Closed
E2	Air Outlet Temperature Sensor Alarm	Sensor Failure	See Note 2 below	Relay Contact Closed
Ht	High Temperature Alarm Default = 55°C	Air inlet temperature greater than 55°C	No effect on function	Relay Contact Closed
Lt	Low Temperature Alarm Default = 14°C	Air inlet temperature less than 14°C	No effect on function	Relay Contact Closed
A1	Frost Alarm	Air outlet temperature less than or equal to -1.0°C	Compressor and Condenser fan off for duration of alarm	Relay Contact Closed
HP/HP1	High Pressure Serious Alarm	High pressure switch open (see note 5 below)	Unit turns OFF for duration of alarm	Relay Contact Closed
LC	Lost Communication Alarm	The Master cannot communicate with any Slave, or the Slave cannot communicate with the Master	No effect on function. Unit will enter standalone mode	N/A
LC1	Lost Communication Alarm	The Master cannot communicate with one of the Slaves	No effect on function. Unit will enter standalone mode	N/A

NOTE 1: Air inlet temperature sensor will default to air outlet temperature sensor. Cooling setpoint defaults to 10°C.

NOTE 2: Unit continues to operate without evaporator freeze protection.

NOTE 3: The MALF high pressure switch is optional.

NOTE 4: The Low pressure switch is optional.

NOTE 5: The High Pressure (HP) or High Pressure Serious (HP1) switch is optional.

MASTER/SLAVE CAPABILITY (OPTIONAL)

The Master/Slave capability is included as standard and can accommodate up to four (4) air conditioners in a single cabinet. In the Master/Slave operating mode, there is a delay period of 20 seconds between startup of each unit during the startup. For example, the master unit number 1 starts first, unit number 2 will start after 20 seconds, followed by unit number 3 after another 20 seconds, and so on....

Note the controller default operating mode is single or standalone. To initiate the Master/Slave operating mode, parameters h24 and h25 require reconfiguration as described below and a TLAN communication cable is also required to interconnect the air conditioners.

- Connect the door open and/or smoke detected harness to the DS1 and DS2 terminals on the enclosure side of the air conditioner unit in parallel. The maximum length of the door switch harness between two air conditioners is 3.33 meters (10 feet). This harness is NOT included with the Master/Slave option. It is offered separately as an accessory.
- Connect the TLAN harness to the MS1 and MS2 terminals on the enclosure side of the air conditioner unit in parallel. The maximum length of the TLAN communication cable is 10 meters (30 feet) and 3.33 meters (10 feet) between the two air conditioners. This harness is NOT included with the Master/Slave option. It is offered separately as an accessory.
- Select one of the units in the group to be the master unit. This is indicated unit number 1.
- Select the slave units, numbers 2, 3 and 4 in sequence.

MASTER/SLAVE OPERATING PARAMETERS

Parameter	Description	Default Value	Range
h24	Device unit ID	0	0 to 4
h25	Number of units	4	2 to 4

NOTE 6: To initiate Master/Slave operating mode, set parameter h24 (device unit ID) of master unit to 1. Set parameter h24 of slave units as applicable. Set parameter h24 (Unit number 2) to 2, set parameter h24 (Unit number 3) to 3, and set parameter h24 (Unit number 4) to 4.

NOTE 7: Set parameter h25 (number of units) of each unit to the same value, for example, h25 = 2 if only two units are connected in a group, h25 = 3 if three units are in a group and h25=4 if 4 units are in a group.

ALARM INPUT CONNECTION

The smart controller can accept a TLAN communication via the 6-POS connector terminals 5 and 6 marked MS1 and MS2 located on the enclosure side of the unit. This TLAN communication is associated with the controller display alarm "LC" and "LC1", lost communication.

To use the TLAN communication feature, simply connect the TLAN harness to MS1 and MS2 terminals and to MS1 and MS2 of each unit in parallel.

The smart controller can accept a dry contact switch input via the 6-POS connector terminals 1 and 2 marked WHT/DS1 and WHT/DS2 located on the enclosure side of the unit. This input is associated with the controller display alarm mnemonic "tP" door open and/or smoke detected.

To use the door open and/or smoke detected feature, simply connect door switch harness to DS1 and DS2 and to DS1 and DS2 of each unit in parallel.

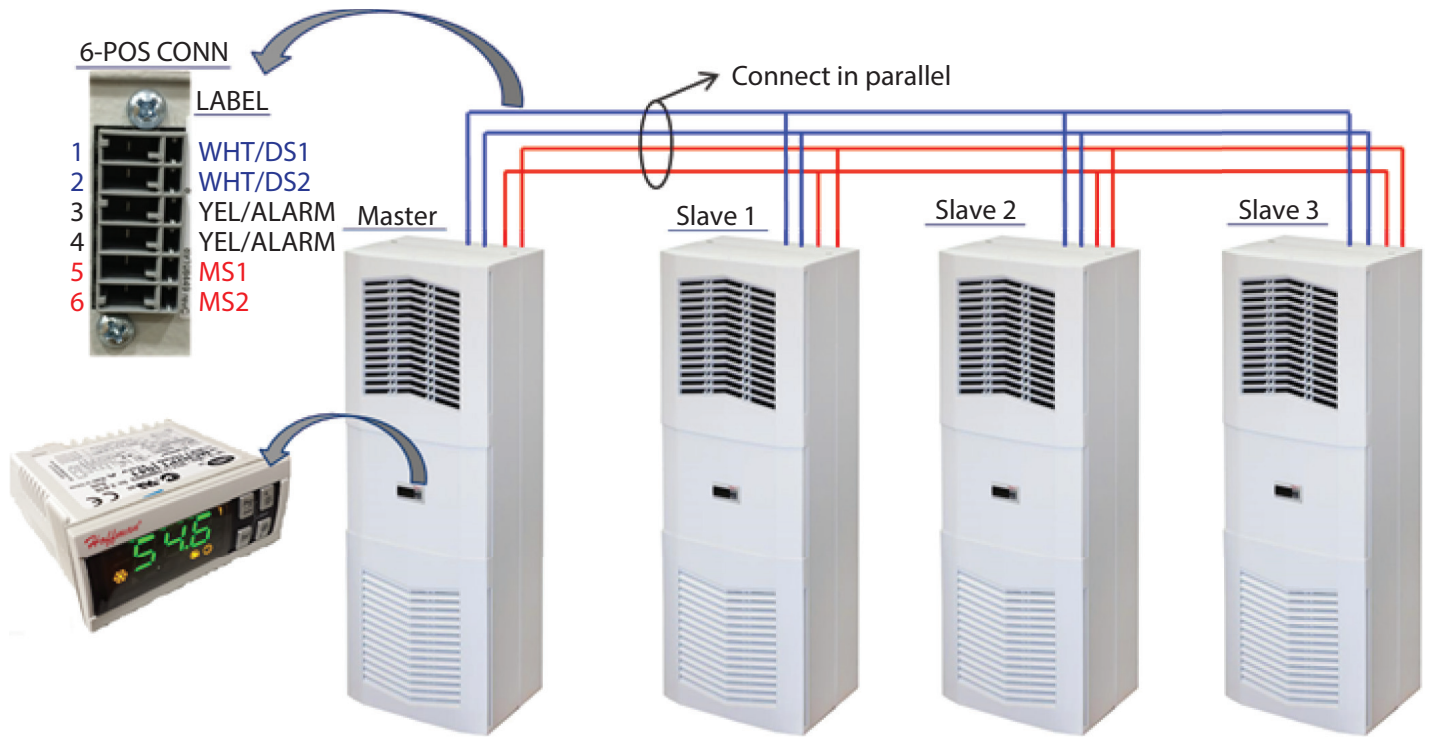

Figure 11
Master/Slave Wiring

REMOTE ACCESS CONTROL

AIR CONDITIONER UNIT COMMUNICATION FEATURES (OPTIONAL)

An optional communication board offers capabilities that include Profinet, EtherNet/IP, Modbus TCP, and SNMP protocols through Ethernet and Modbus RTU protocol via USB. Pentair has a PC Interface Tool available for download that can utilize either mode to communicate with the air conditioner unit.

USB COMMUNICATION

This communication mode allows direct connection of a PC to the air conditioner unit. The protocol supported is Modbus RTU. Use the Pentair AC monitor to communicate with the air conditioner unit. A MINI-b USB connection is included with this option.

ETHERNET COMMUNICATION

This communication mode allows remote connection to the air conditioner unit using SNMP, EtherNet/IP and Modbus/TCP, and Profinet protocols. Customers using their own software can download a MIB file for SNMP, EDS file or EtherNet/IP Object file for EtherNet/IP, Coil Register file for Modbus TCP, and GSDML file for Profinet.

Note: The ACU has a default IP Address of 192.168.1.2

Both Ethernet and USB communication modes allow the ability to:

- Read ACU inlet and outlet air temperature
- Read and change Cooling Setpoint and Cooling Differential
- Read and change High and Low Temperature Alarm Settings
- Read and change Gateway IP Address, Device IP Address, Subnet Mask, Trap IP Address and SNMP Community
- Read and change Unit Identification
- Read and change the type of IP addressing (static or dynamic)
- Read current Alarm Status
- Read MAC Address
- Read and change the door open and/or smoke detected switch functionality

MASTER/SLAVE CAPABILITY (OPTIONAL)

In the Master/Slave application, only one Remote Access Communication board is required. All the alarms are communicated through the TLAN serial connection, except the door open and/or smoke detected alarm. Door open and/or smoke detected function can be remotely changed from Normally Open to Normally Close if needed.

Note: If the door open and/or smoke detected harness is not used, and the door switch is wired to only one of the units, for instance, the master unit. If the power of the master unit is OFF, the slave units will not detect the door open alarm and they will continue operating in standalone mode even if the door is open.

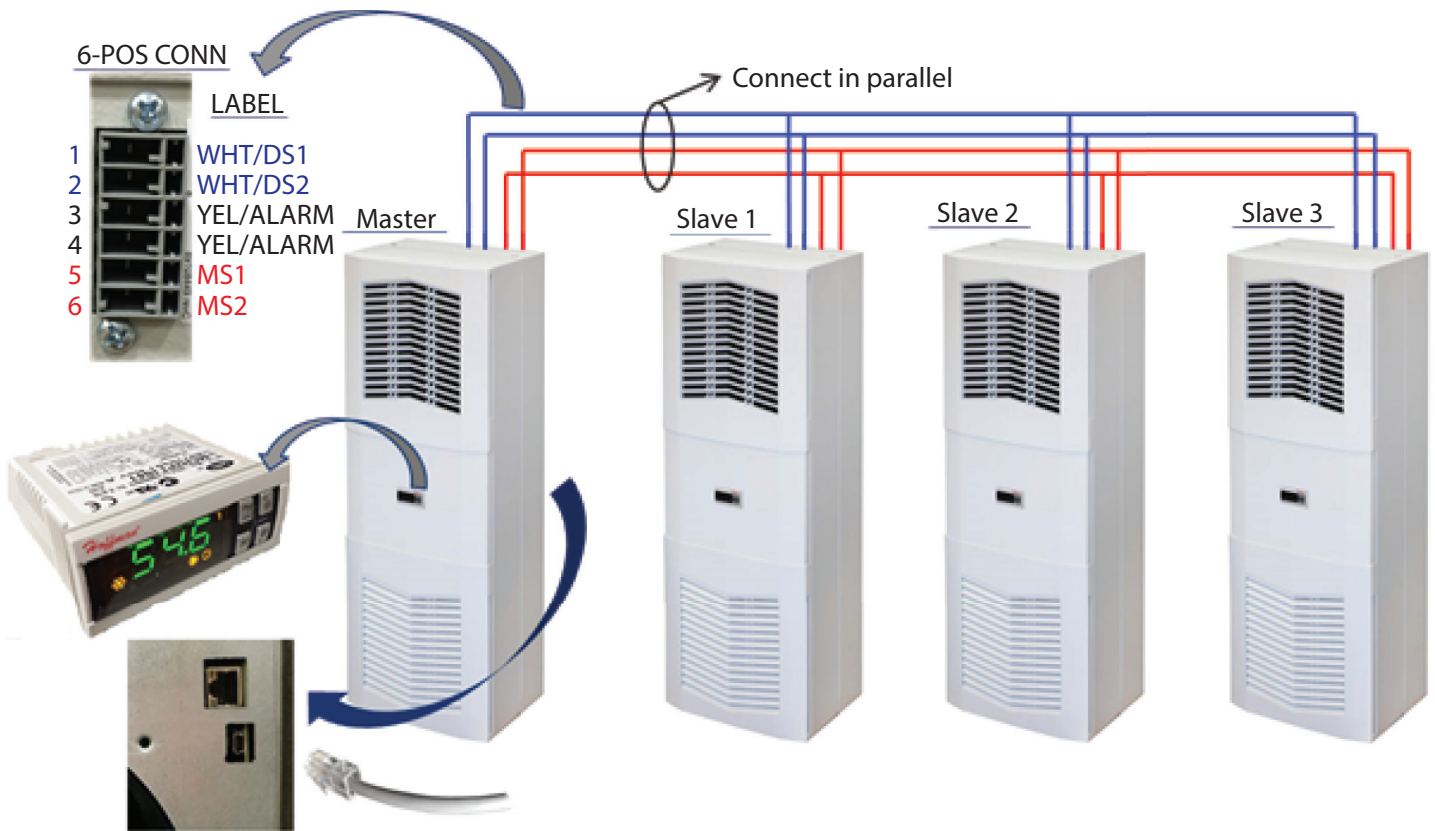

Figure 12
Master/Slave with Remote Access

SOFTWARE AND CONFIGURATION FILE DOWNLOADS

The Pentair AC monitor, MIB file, EDS file, EtherNet_IP Object file, Coil Register file, and GSDML file for Profinet can be downloaded from: www.pentairprotect.com/en/hoffman/thermal-management

Scroll down to "Relevant Downloads and search under Remote Access Control".

<p>RELEVANT DOWNLOADS</p> <ul style="list-style-type: none"> Thermal Management Specifier's Guide Cooling Brochure Hoffman Cooling EasySpec Guide Hoffman Cooling EAC Certificate <p>REMOTE ACCESS CONTROL</p> <ul style="list-style-type: none"> Instruction Manual V3.0.5 Remote Access Set Up Remote Access (MIB) SNMP Sample Commands EtherNet IP Objects EtherNet IP Download Modbus TCP Registers and Coils Profinet Data Points 	<p>RELATED LINKS</p> <ul style="list-style-type: none"> Cooling Selection Tool Hoffman Distributor Locator Maintenance and Repair Hoffman Cooling Easy Swap APP <p>Note: Hoffman Cooling User Manuals can be found under the Downloads Tab in product information.</p>
--	---

REMOTE ACCESS CONTROL PIN-OUT

	FUNCTION	NAME	PIN #
U1 OUTPUTS	COOL	No1	1
		C1/2	2
		C1/2	3
	ALARM RELAY OUTPUT	No5	15
		C5	6
U2 INPUTS	ENCLOSURE DOOR "NO" SWITCH	ID1	8
	MALFUNCTION "NC" SWITCH	ID2	1
	NA	DI3 (na)	9
	NA	DI4 (na)	2
	DIGITAL INPUT GROUND	DI GND	3
	T1, EVAP IN THERMISTOR	B1	13
	T2, EVAP OUT THERMISTOR	B2	12
	T1, T2 GND	GND	6
	NA	B3	11
	CONTROLLER POWER	G	7
	CONTROLLER POWER	G0	14
U3 DATA	POWER		1
	GROUND		2
	DIRECTION		3
	DATA		4
U4 DATA	TRANSMIT/RECEIVE	TX/RX	1
	GROUND	DI GND	2

NOTES

TECHNICAL INFORMATION
S06 MODELS 300/500W
S06 SCHEMATIC 300/500W

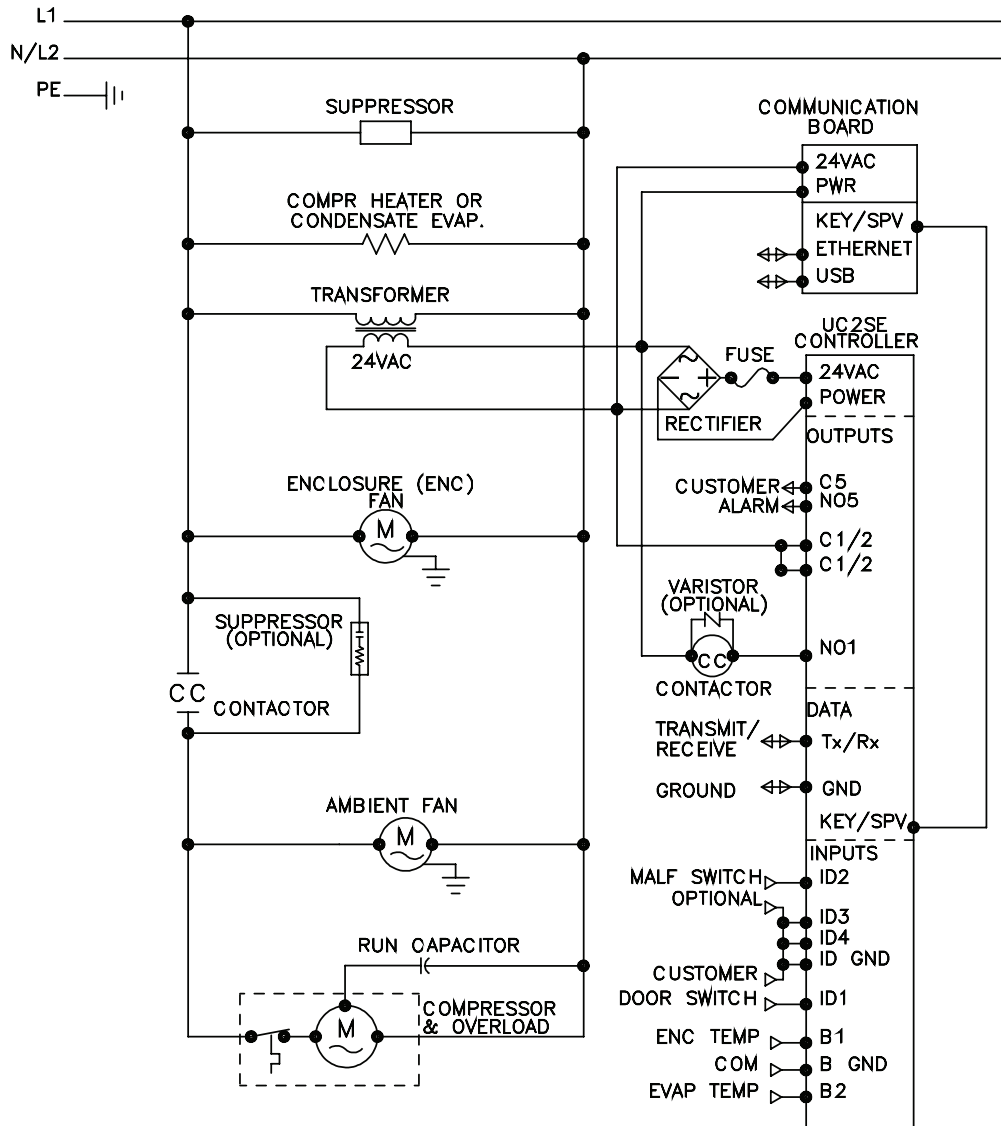

89107580 REV. F

ELECTRICAL SCHEMATIC

S06 WIRE DIAGRAM 300/500W

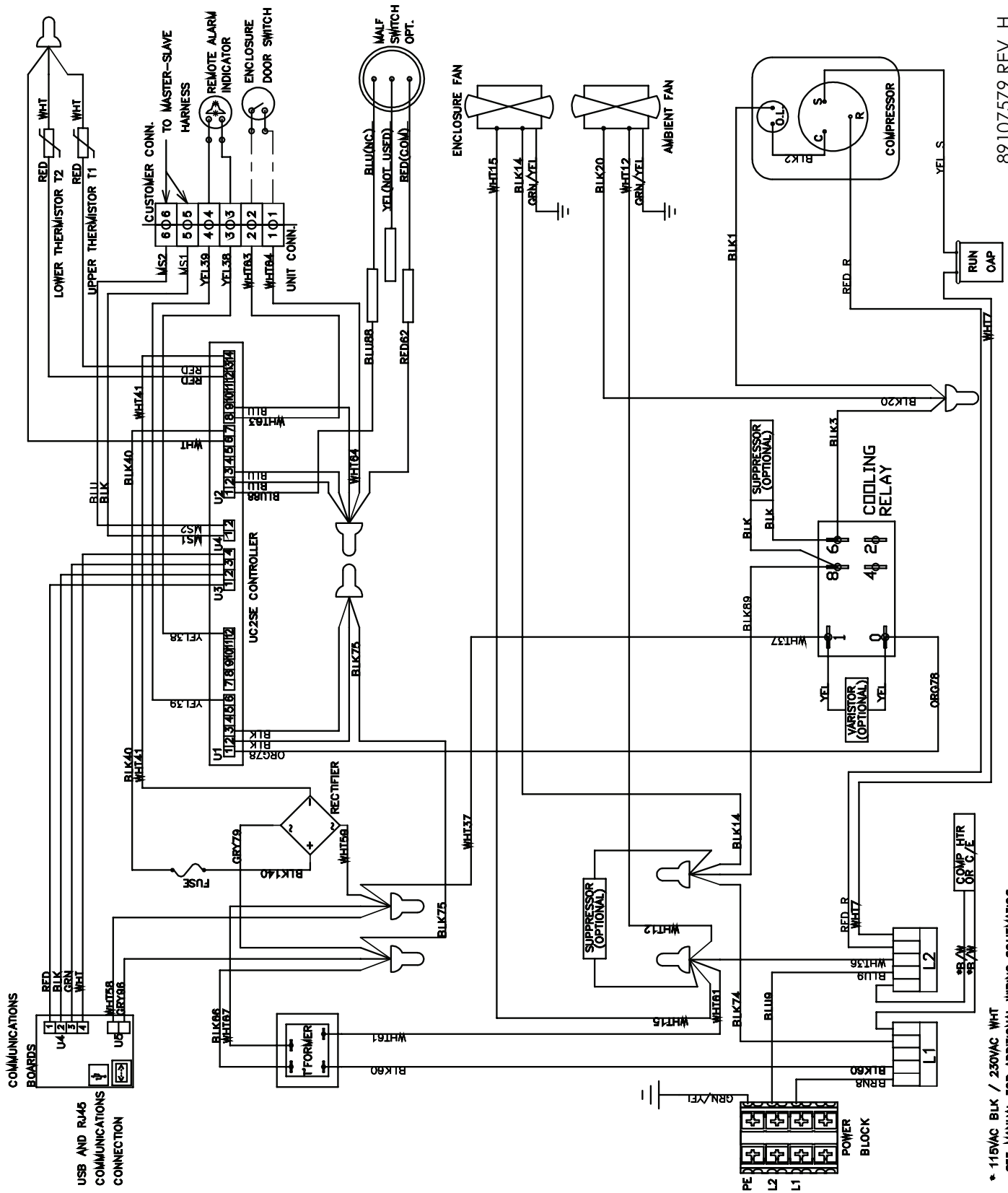

89107579 REV. H

* 115VAC BLK / 230VAC WHT
 --SEE MANUAL FOR ADDITIONAL WIRING SCHEMATICS

S06 DIMENSIONAL DRAWINGS

300W

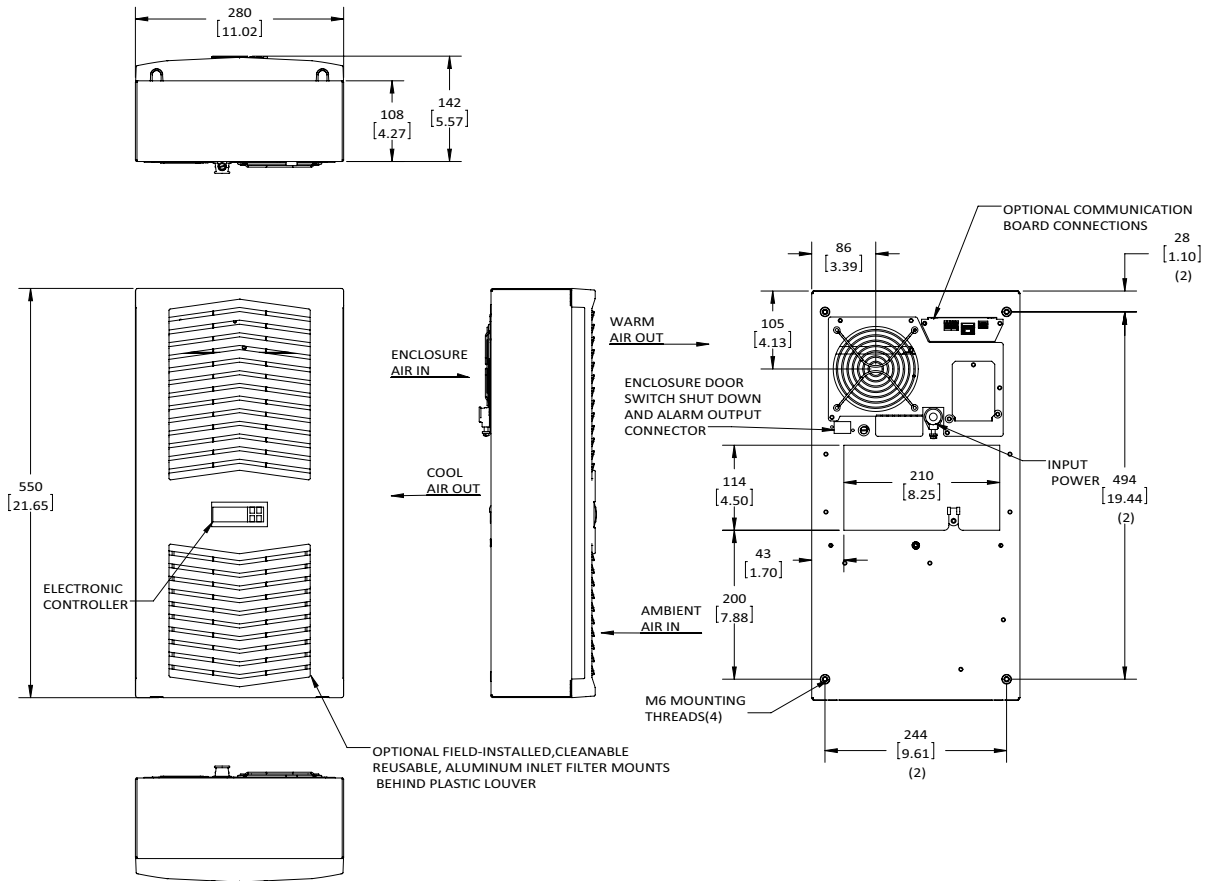

500W

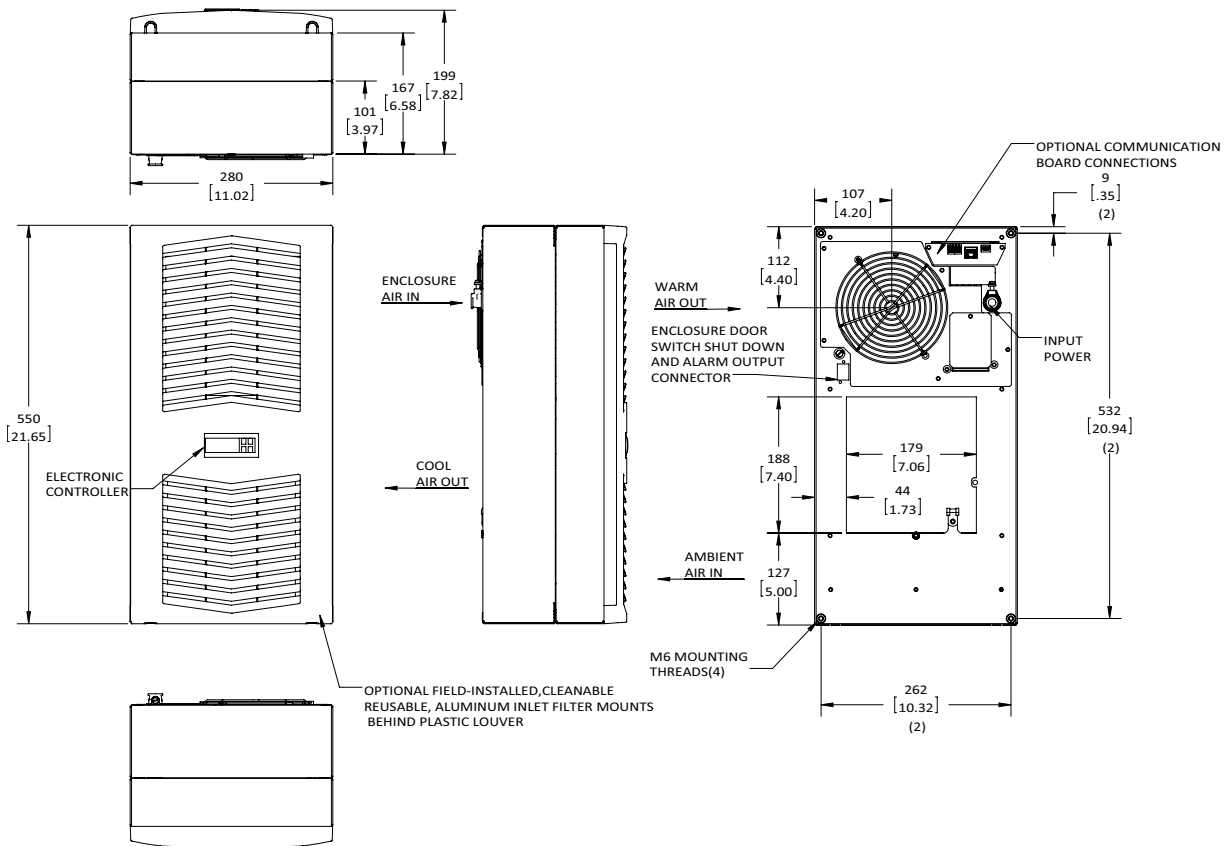

S06 INSTALLATION INSTRUCTION

1. See Receiving The Air Conditioner and Handling and Testing The Air Conditioner on page 6.
2. Using the cutout template provided with the unit, prepare the enclosure. See Figure 13 and Figure 14. The front of the unit requires a half meter clearance for proper airflow. Five centimeters is required on each side of the unit. To avoid condensate overflow, unit must be mounted within 3° of level.
3. Refer to mounting instructions on page 8.
4. Adjust controller to desired cabinet temperature. Refer to Displaying and Changing Program Variables on page 13 for controller adjustment and operation.

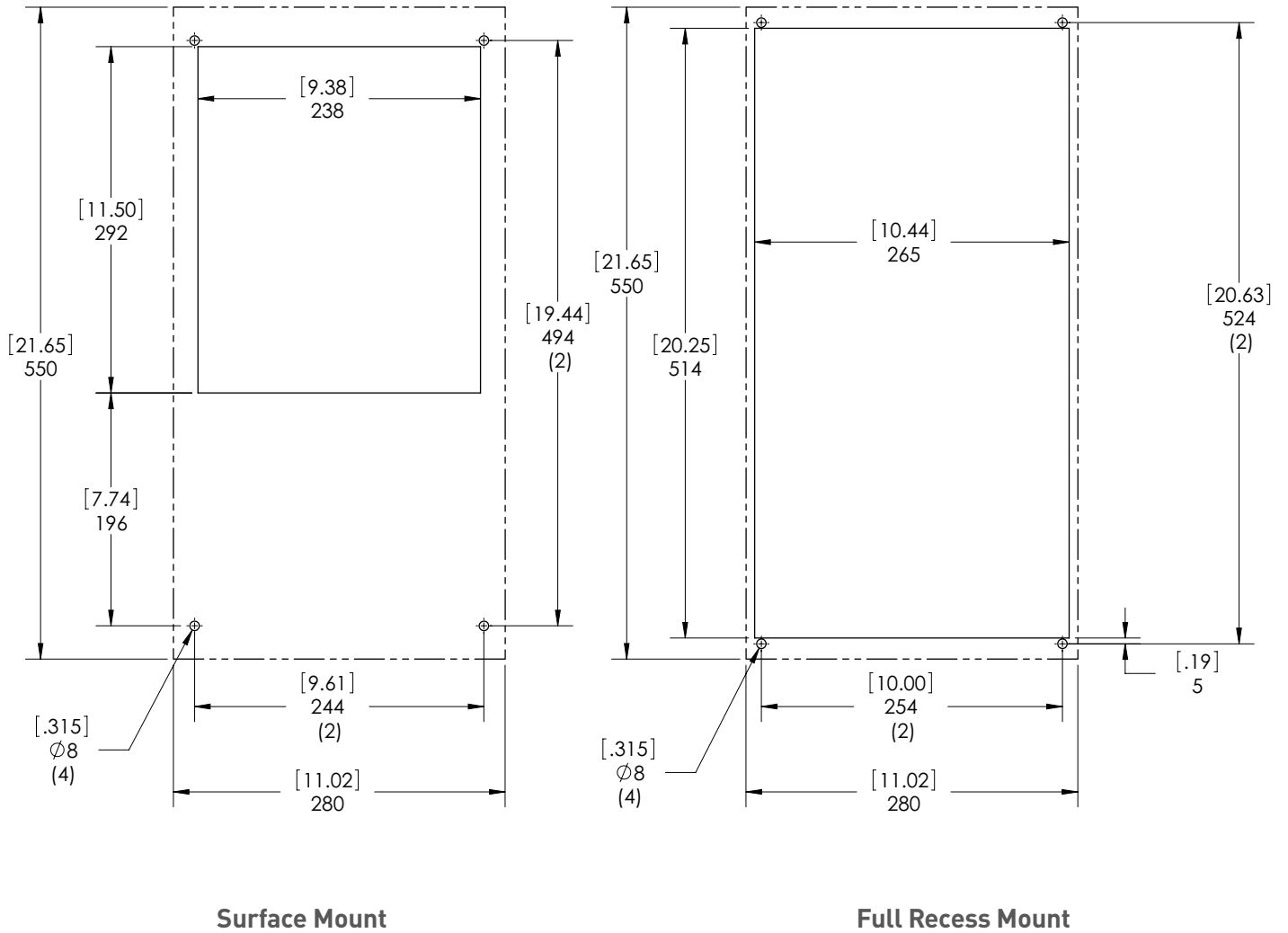

Figure 13
S06 300W Cutout Drawing
 Dashed Lines Represent The Air Conditioner

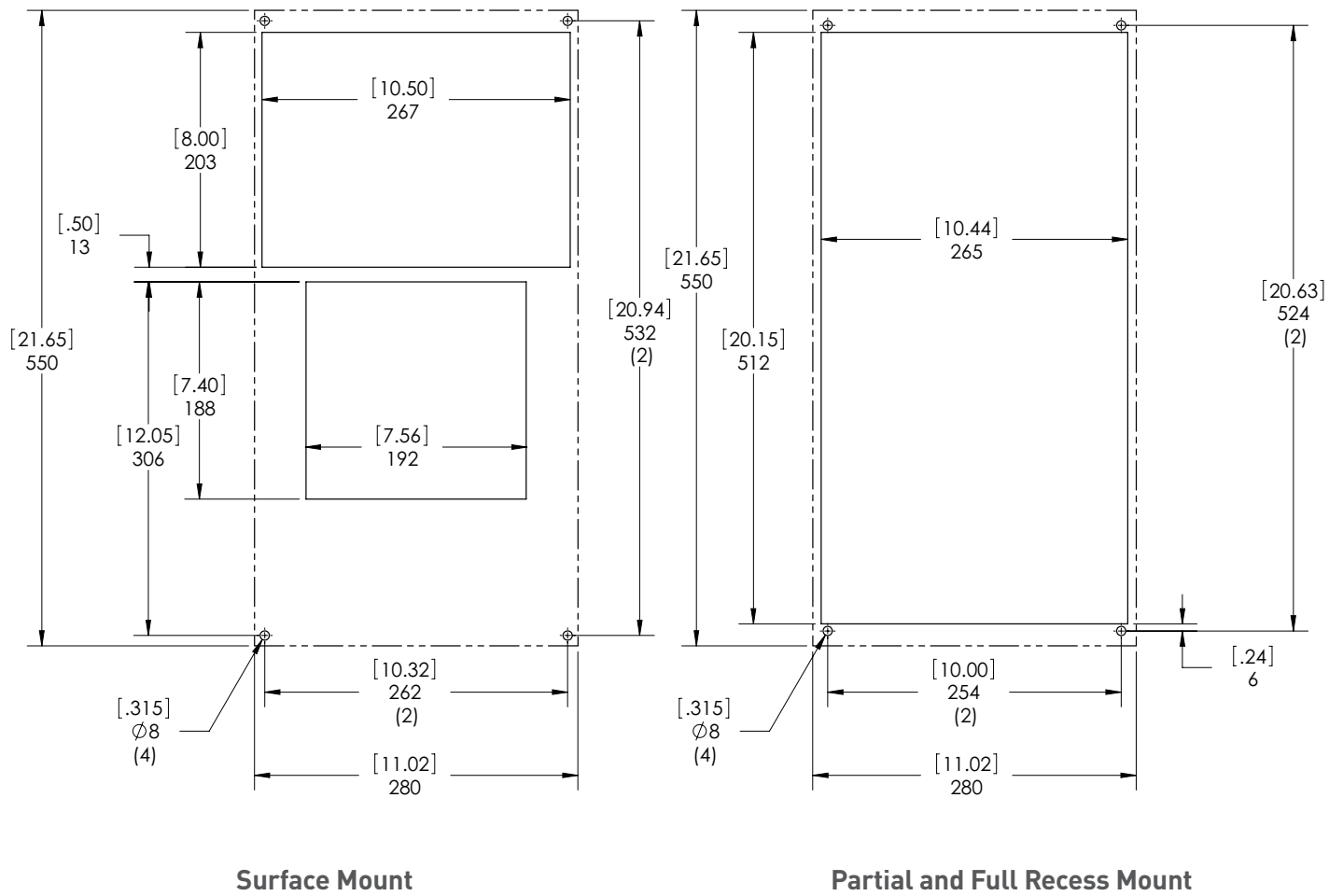

Figure 14
S06 500W Cutout Drawing
 Dashed Lines Represent The Air Conditioner

S06 UNIT CHARACTERISTICS

UNIT	300W 115V	300W 230V	500W 115V	500W 230V
CATALOG NUMBER				
Indoor Model without Communications Board (°C Controller)	S060316G031	S060326G031	S060516G031	S060526G031
Indoor Model with Communications Board (°C Controller)	S060316G041	S060326G041	S060516G041	S060526G041
Indoor Model without Communications Board (°F Controller)	S060316G050	S060326G050	S060516G050	S060526G050
Indoor Model with Communications Board (°F Controller)	S060316G060	S060326G060	S060516G060	S060526G060
COOLING PERFORMANCE				
Total L35 L35, 50Hz, according to DIN EN 14511 (Watt)	370	370	550	550
Cooling performance L35 L35 (Watt) 50/60Hz	370 / 420	370 / 420	550 / 640	550 / 640
Cooling performance L35 L50 (Watt) 50/60Hz	190 / 230	190 / 230	320 / 380	320 / 380
Refrigerant	R134a	R134a	R134a	R134a
Refrigerant Charge (g)	133	128	162	162
Max. allowable operating pressure (p. max.) bar	28	28	28	28
Operating Temperature Range (Min/Max °C)	10 / 52 (50Hz) 10 / 55 (60Hz)	10 / 55	10 / 55	10 / 55
Operating Temperature Range (Min/Max °F)	50 / 126 (50Hz) 50 / 131 (60Hz)	50 / 131	50 / 131	50 / 131
Setting Temperature Range (Min. / Max. °C Controller)	20 / 55	20 / 55	20 / 55	20 / 55
Setting Temperature Range (Min. / Max. °F Controller)	72 / 120	72 / 120	72 / 120	72 / 120
Airflow at 0 Static Pressure:				
Internal loop (m³/h)	109 / 124	109 / 124	197 / 233	197 / 233
External loop (m³/h)	129 / 156	129 / 156	189 / 219	189 / 219
Duty Cycle	100%	100%	100%	100%
ELECTRICAL DATA				
Rated Voltage (Volt)	100 / 115	230	115	230
Phase	1~	1~	1~	1~
Frequency (Hz)	50/60	50/60	50/60	50/60
Operating Range	+/- 10%	+/- 10%	+/- 10%	+/- 10%
Max power Consumption 50/60Hz L35 L35 (Watt)	270 / 300	300 / 320	450 / 470	450 / 480
Max power Consumption 50/60Hz L35 L50 (Watt)	280 / 320	330 / 350	490 / 540	510 / 540
Max. Nominal Current (Amps)	4.0 / 3.8	1.8 / 1.7	6.5 / 6.1	2.6 / 2.9
Starting Current (Amps)	13 / 13	6.0 / 6.0	21 / 20	9.0 / 10.0
Pre-fuse T (Amps)	15	15	15	15
Agency Approvals	UL listed, cUL listed, EAC, CE			
Power Input Description	Terminal Block			
PERFORMANCE FACTOR (EER), 50Hz, DIN EN 14511				
Cooling Performance L35 / L35	1.37 / 1.40	1.23 / 1.31	1.22 / 1.36	1.24 / 1.35
Cooling Performance L35 / L50	0.68 / 0.70	0.58 / 0.65	0.64 / 0.70	0.62 / 0.70
ENCLOSURE PROTECTION				
IP Code (External loop / Internal loop)	IP34 / IP54	IP34 / IP54	IP34 / IP54	IP34 / IP54
CONTROLLER				
Description	Smart controller with display			
Controller Location	Ambient side			
Factory Default Setpoint (°C Controller)	35	35	35	35
Factory Default Setpoint (°F Controller)	80	80	80	80
SOUND LEVEL				
At 1 M (dBA)	66	66	68	68
UNIT CONSTRUCTION				
Material	Steel		Steel	
Finish	RAL 7035		RAL 7035	
UNIT DIMENSIONS				
Height (mm)	550	550	550	550
Width (mm)	280	280	280	280
Depth (mm)	140	140	206	206
Weight (kg)	13	13	15	15

S06 COMPONENTS

Item	Model Series	300W 115V	300W 230V	500W 115V	500W 230V
Part Descriptions		Part Numbers			
1	Capacitor, Compressor, Run	52603209SP	52603210SP	89107709SP	89106525SP
2	Capillary Tube	99042047SP	99042047SP	99054030SP	99054030SP
3	Coil, Condenser	89110804SP	89110804SP	89107198SP	89107198SP
4	Coil, Evaporator	89107600SP	89107600SP	89107023SP	89107023SP
5	Communication Board (optional)	89109039SP	89109039SP	89109039SP	89109039SP
6	Compressor	10101682SP	101026101SP	89109026SP	89108369SP
7	Contacting Compressor	10100536SP	10100536SP	10100536SP	10100536SP
8	Smart Controller °C	89123540SP	89123540SP	89123540SP	89123540SP
	Smart Controller °F	90272220SP	90272220SP	90272220SP	90272220SP
9	Drain Tube Kit (optional)	101027177SP	101027177SP	101027177SP	101027177SP
10	Filter Air, Reusable (optional)	89106978SP	89106978SP	89106978SP	89106978SP
11	Filter/Dryer	52602803SP	52602803SP	52602803SP	52602803SP
12	Fan, Condenser	89117829SP	89117830SP	89117829SP	89117830SP
13	Fan, Evaporator	13101501SP	13101502SP	12101201SP	12101202SP
14	Thermal Overload, Compressor	10100767SP	10100768SP	89109877SP	89112627SP
15	Thermistor	89075654SP (2)	89075654SP (2)	89075654SP (2)	89075654SP (2)
16	Transformer, 24V	10100694SP	10100693SP	10100694SP	10100693SP
17	Fuse (Controller)	89085114SP	89085114SP	89085114SP	89085114SP
Accessories					
18	Installation Kit	90221634QDSP	90221634QDSP	90221634QDSP	90221634QDSP
19	Unit Mounting Gasket	90241618SP	90241618SP	90241618SP	90241618SP
20	Mounting standoffs	NA	NA	89105488SP (4)	89105488SP (4)
Structural Parts					
21	Louvered Grill Panel	89105442SP	89105442SP	89105442SP	89105442SP
22	Panel Strike Clip (Pkg. 4)	90245472SP	90245472SP	90245472SP	90245472SP
23	Body Catch Clip (Pkg. 4)	89105486SP	89105486SP	89105486SP	89105486SP
24	Body Front Shell	NA	NA	89104023SP	89104023SP

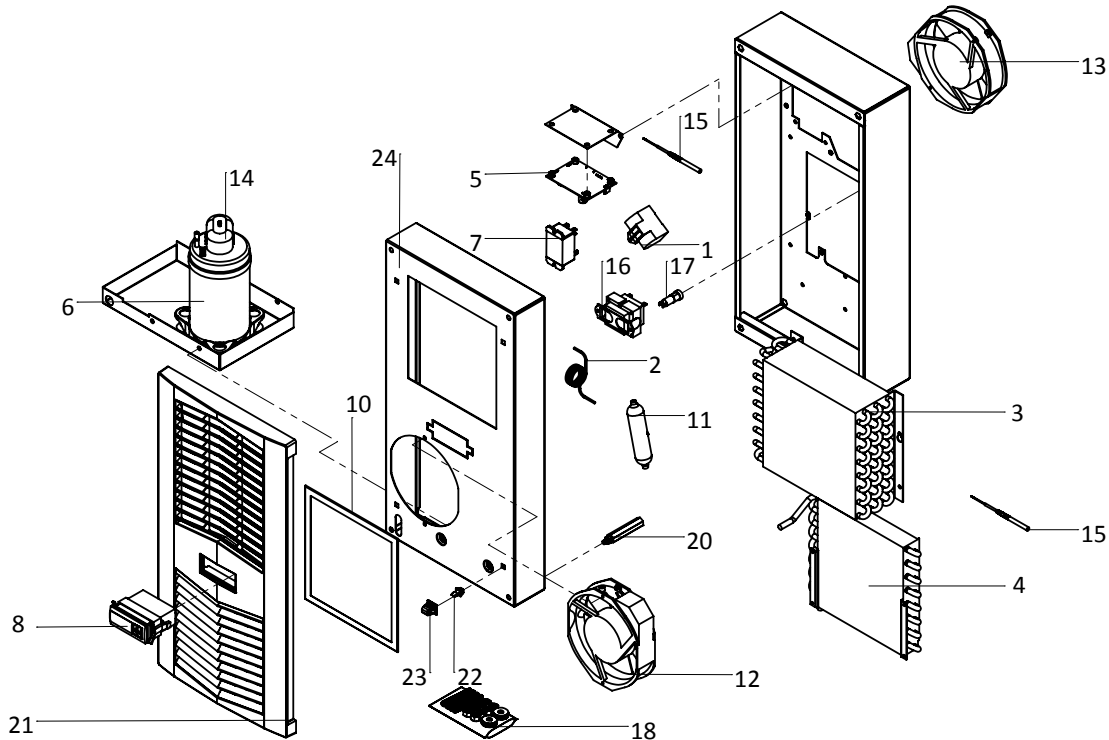

S10 MODELS 1000/1500W

S10 SCHEMATICS

1000W 115V, 230V

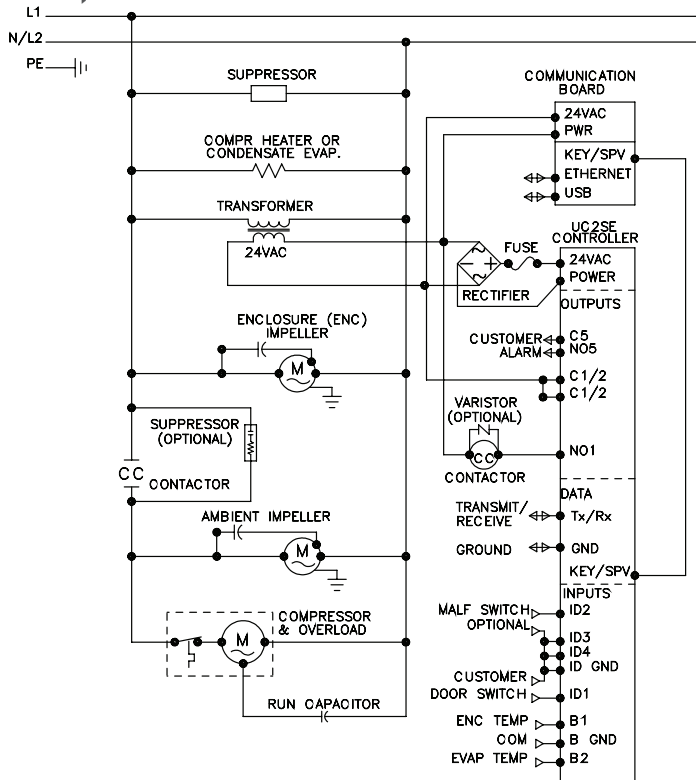

ELECTRICAL SCHEMATIC

89107582 REV. F

1000W 460V

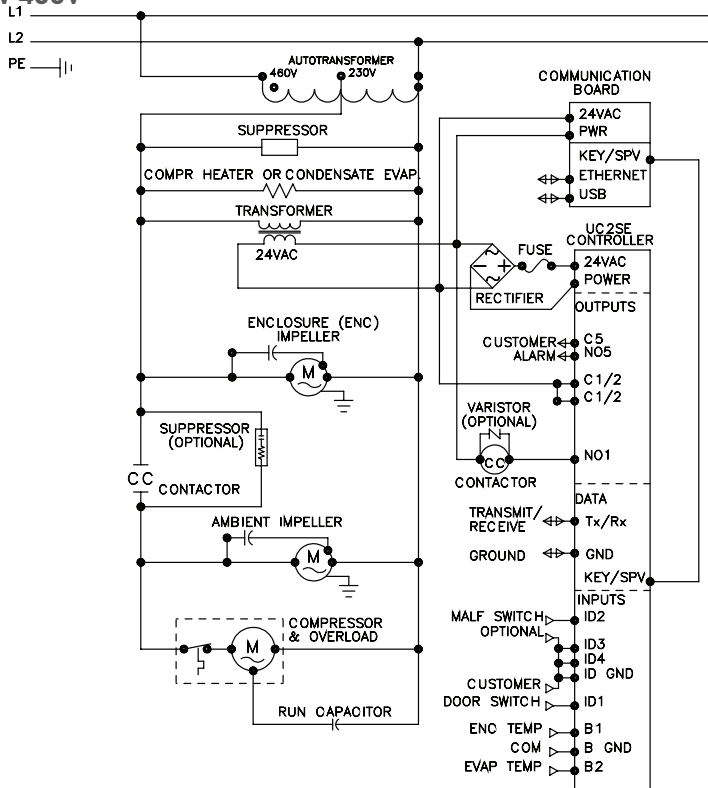

ELECTRICAL SCHEMATIC

89107584 REV. D

1500W 115V

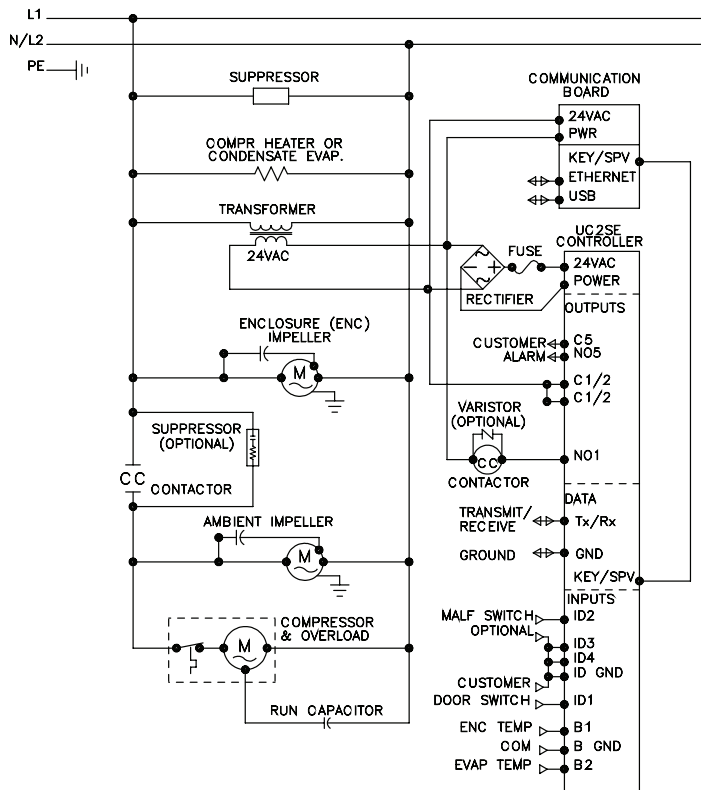

ELECTRICAL SCHEMATIC

89107582 REV. F

1500W 230V

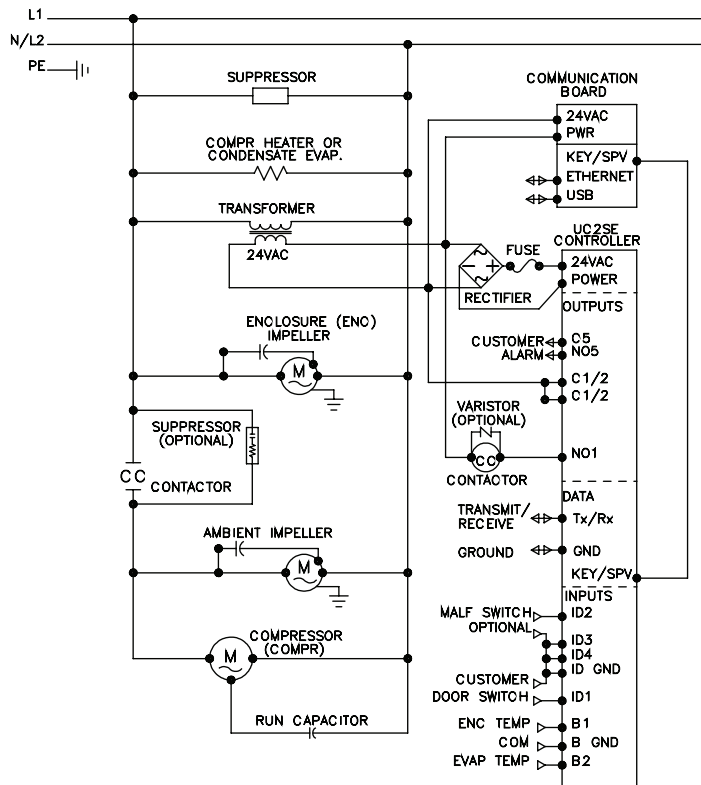

ELECTRICAL SCHEMATIC

89107586 REV. G

1500W 460V

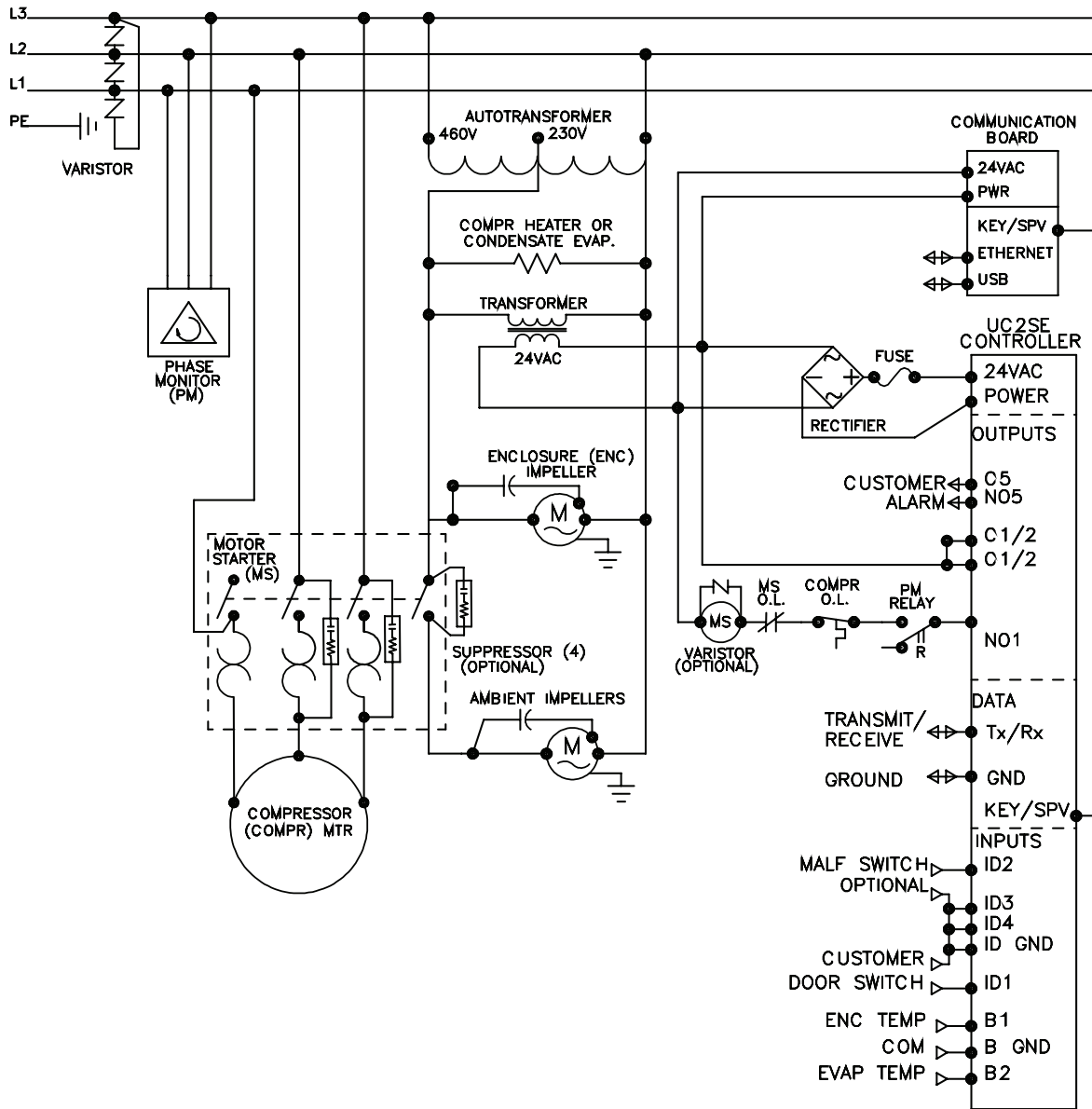

89107589 REV. H

ELECTRICAL SCHEMATIC

S10 WIRE DIAGRAMS

1000W 115V, 230V

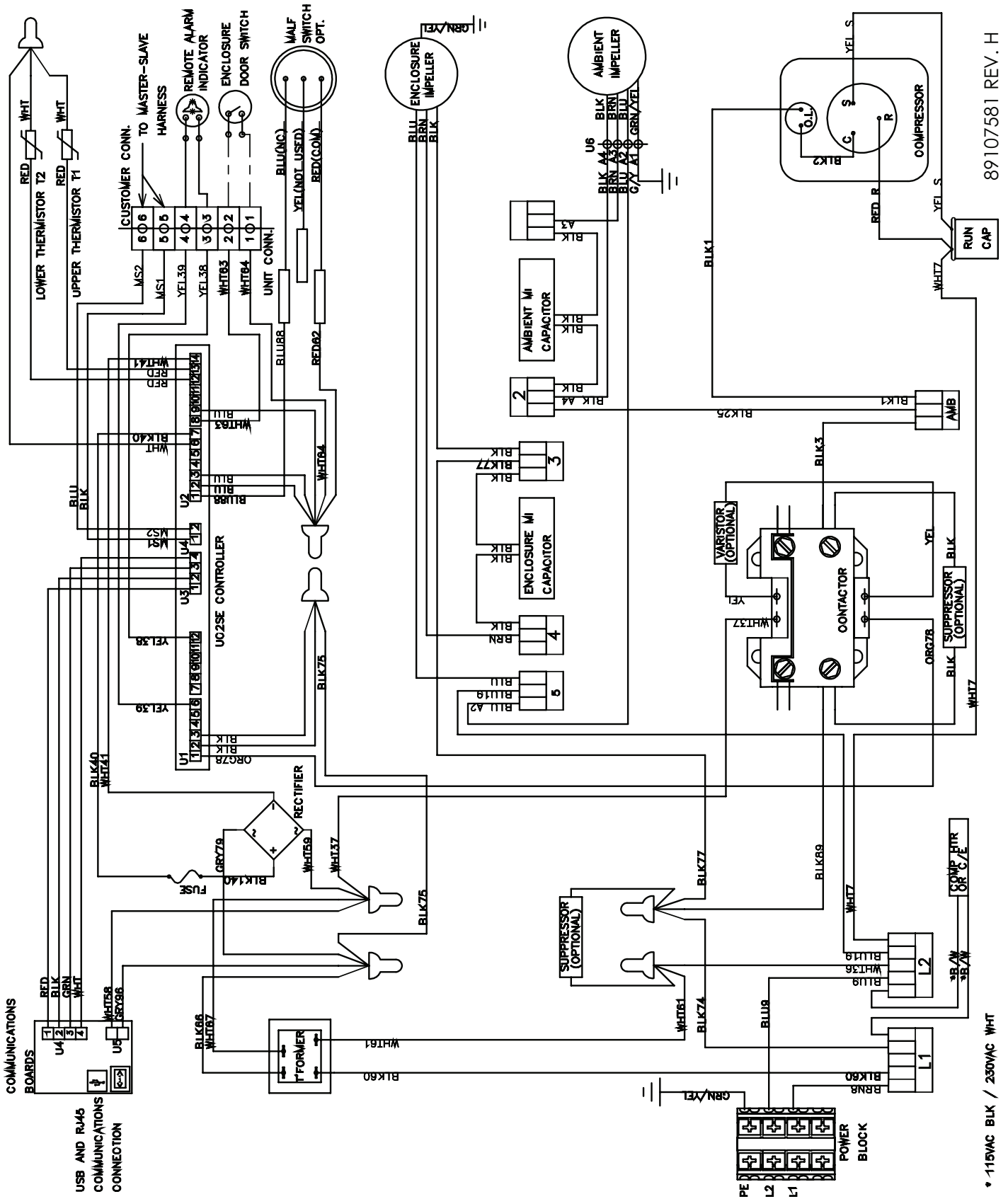

89107581 REV. H

• 115VAC BLK / 230VAC WHT

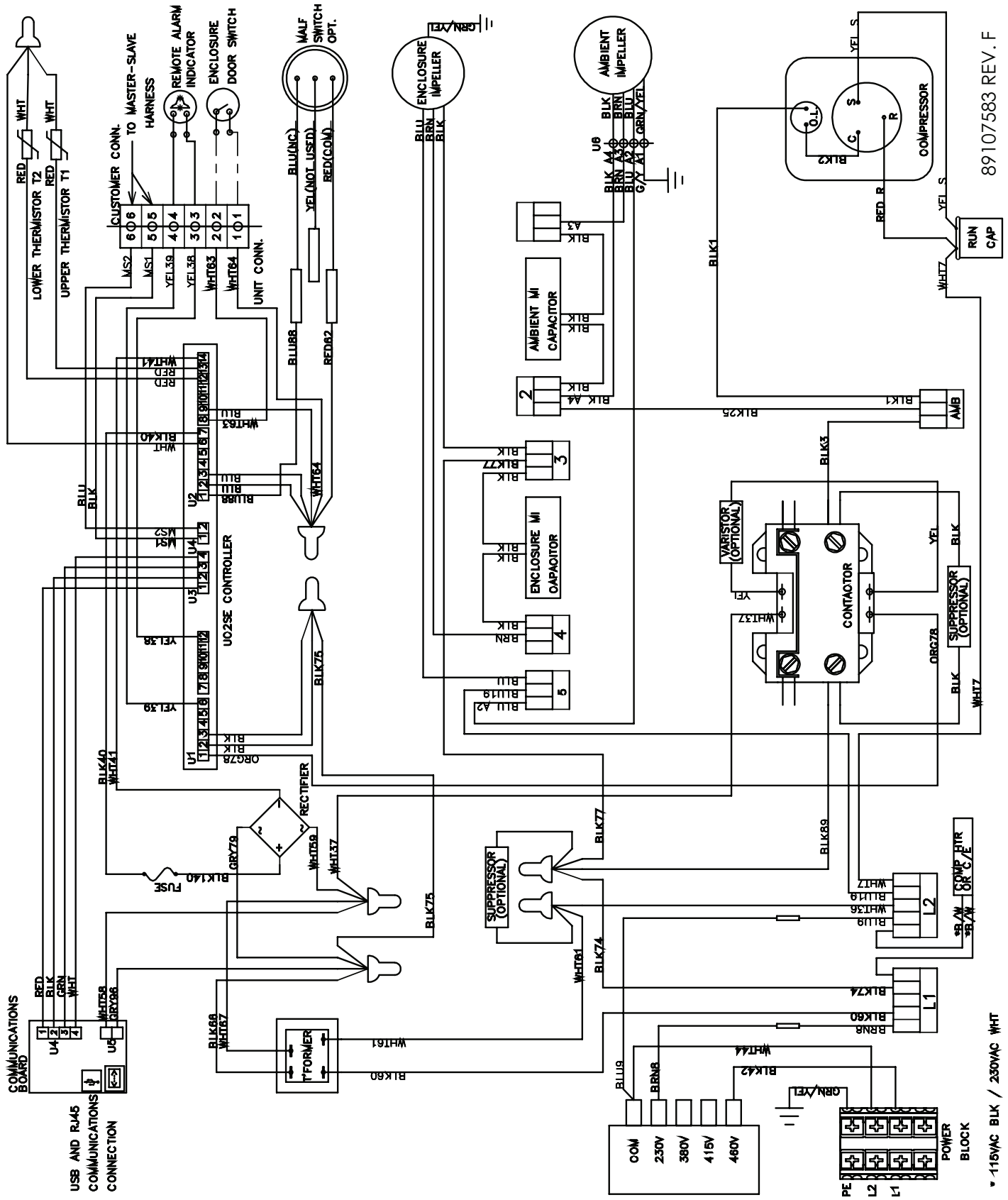

89107583 REV. F

~ 115VAC BLK / 230VAC WHT

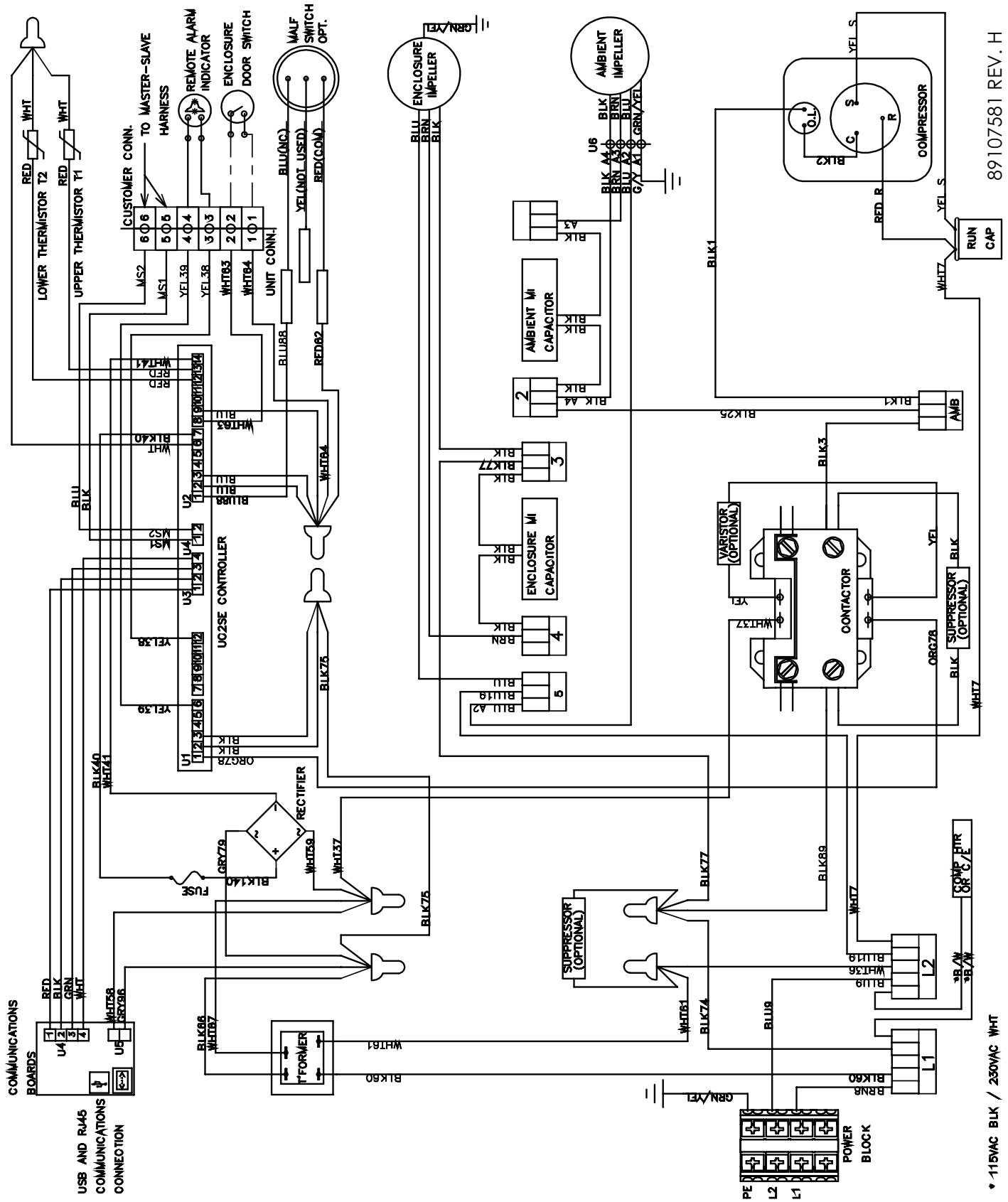

89107581 REV. H

• 115VAC BLK / 230VAC WHT

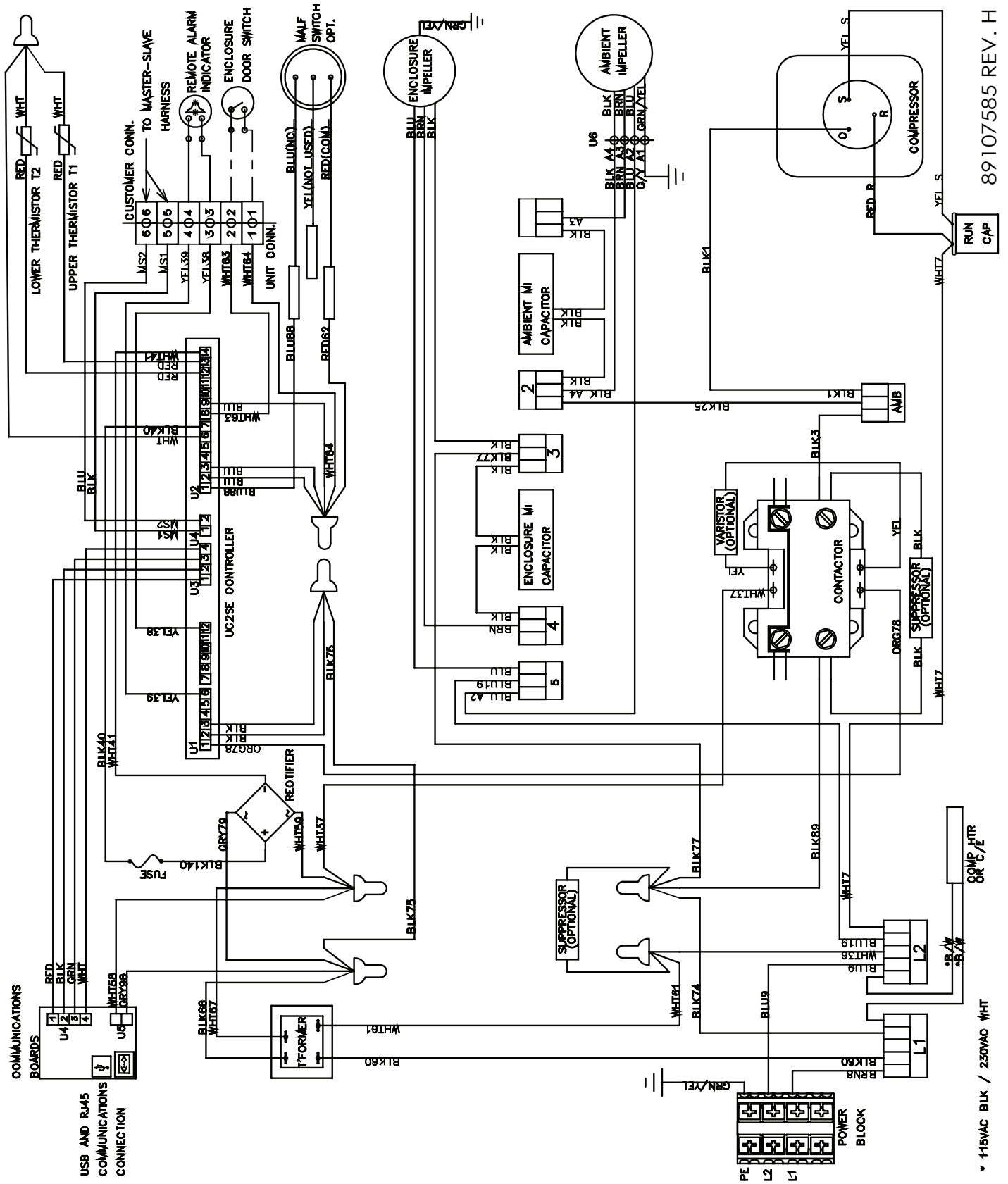

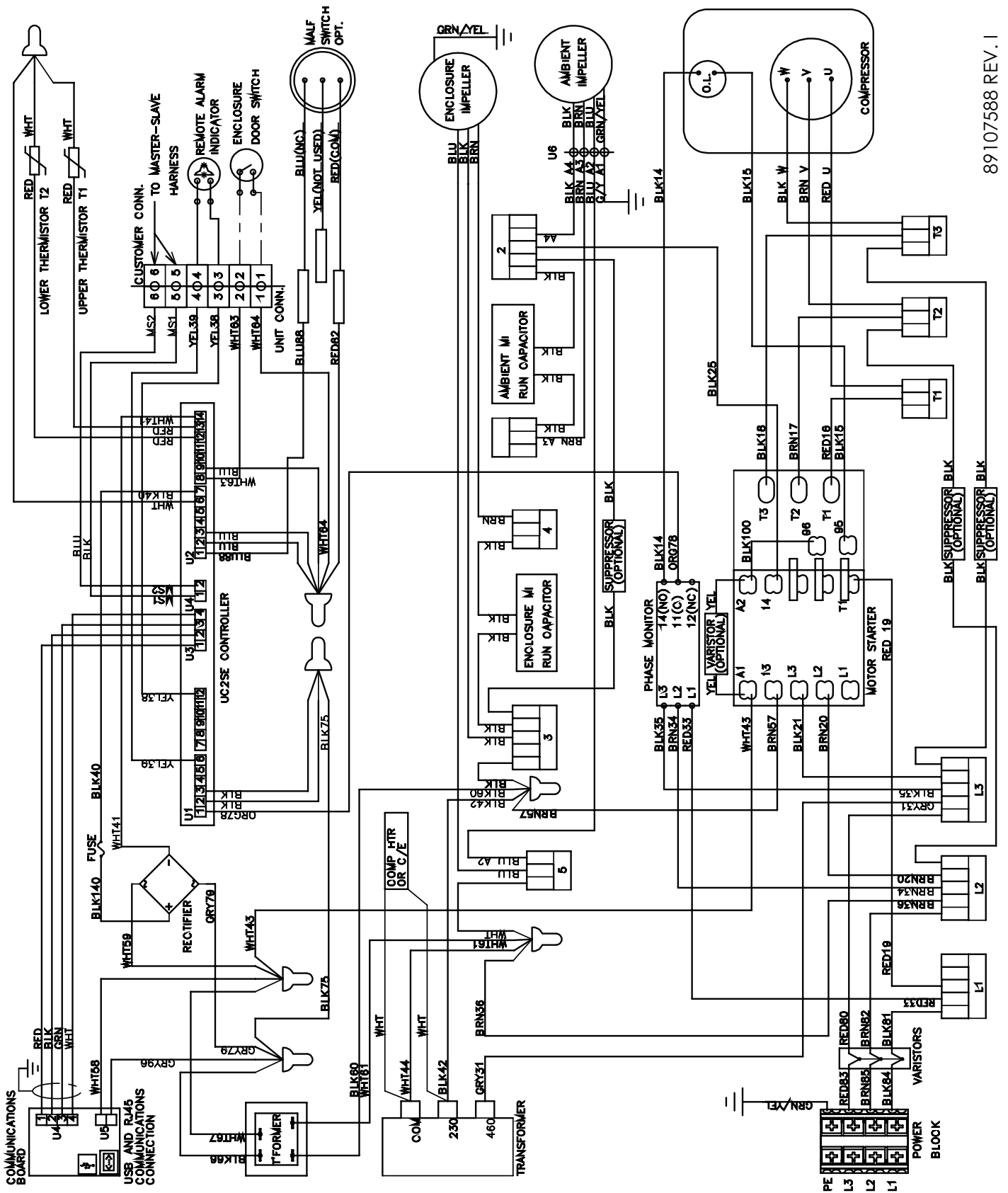

S10 DIMENSIONAL DRAWING 1000/1500W

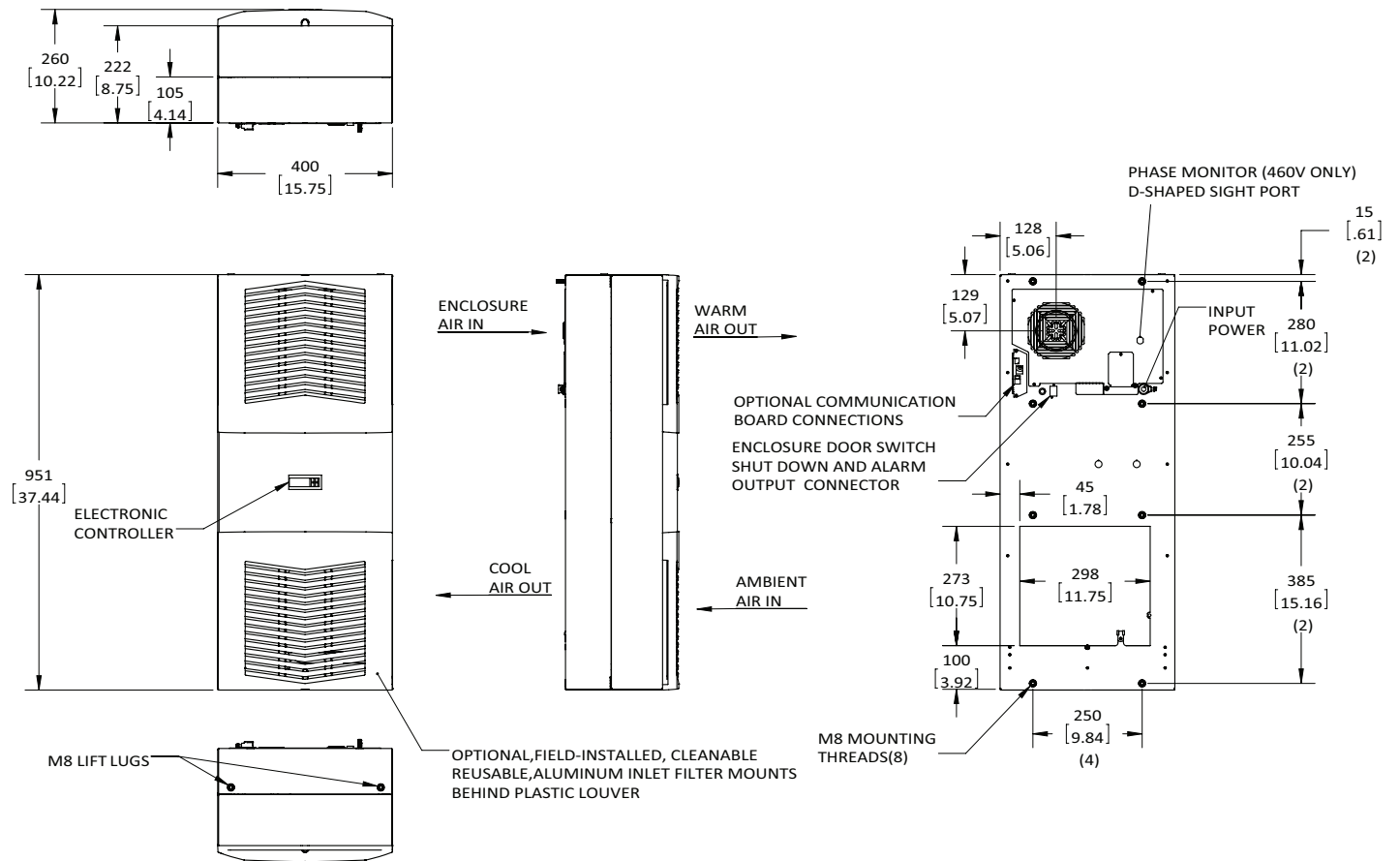

S10 INSTALLATION INSTRUCTION

1. See Receiving The Air Conditioner and Handling and Testing The Air Conditioner on page 6.
2. Using the cutout template provided with the unit, prepare the enclosure. See Figure 15. The front of the unit requires a half meter clearance for proper airflow. Five centimeters is required on each side of the unit. To avoid condensate overflow, unit must be mounted within 3° of level.
3. Refer to mounting instructions on page 8.
4. Adjust controller to desired cabinet temperature. Refer to Displaying and Changing Program Variables on page 13 for controller adjustment and operation.

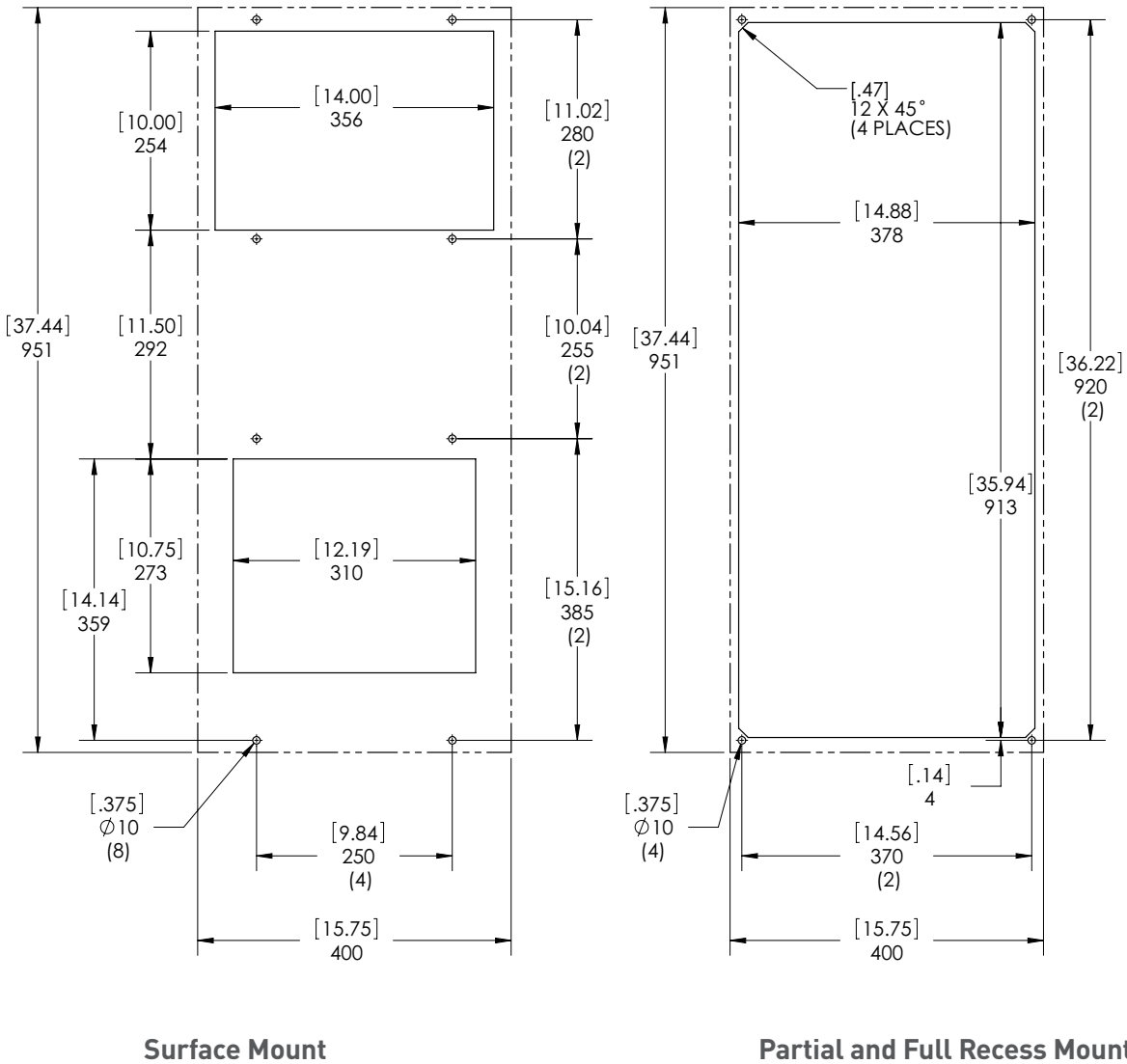

Figure 15
S10 1000/1500W Cutout Drawing
 Dashed Lines Represent The Air Conditioner

S10 UNIT CHARACTERISTICS (115V, 230V)

UNIT	1000W 115V	1000W 230V	1500W 115V	1500W 230V
CATALOG NUMBER				
Indoor Model without Communications Board (°C Controller)	S101016G031	S101026G031	S101516G031	S101526G031
Indoor Model with Communications Board (°C Controller)	S101016G041	S101026G041	S101516G041	S101526G041
Indoor Model without Communications Board (°F Controller)	S101016G050	S101026G050	S101516G050	S101526G050
Indoor Model with Communications Board (°F Controller)	S101016G060	S101026G060	S101516G060	S101526G060
COOLING PERFORMANCE				
Total L35 L35, 50Hz, according to DIN EN 14511 (Watt)	1300	1300	1800	1800
Cooling performance L35 L35 (Watt) 50/60Hz	1300 / 1380	1300 / 1380	1800 / 1880	1800 / 1880
Cooling performance L35 L50 (Watt) 50/60Hz	900 / 1000	900 / 1000	1300 / 1380	1300 / 1380
Refrigerant	R134a	R134a	R134a	R134a
Refrigerant Charge (g)	425	283	425	425
Max. allowable operating pressure (p. max.) bar	28	28	28	28
Operating Temperature Range (Min/Max °C)	10 / 55	10 / 55	10 / 55	10 / 55
Operating Temperature Range (Min/Max °F)	50 / 131	50 / 131	50 / 131	50 / 131
Setting Temperature Range (Min. / Max. °C Controller)	20 / 55	20 / 55	20 / 55	20 / 55
Setting Temperature Range (Min. / Max. °F Controller)	72 / 120	72 / 120	72 / 120	72 / 120
Airflow at 0 Static Pressure:				
Internal loop (m³/h)	350 / 391	350 / 391	342 / 391	342 / 391
External loop (m³/h)	567 / 584	567 / 584	576 / 579	576 / 579
Duty Cycle	100%	100%	100%	100%
ELECTRICAL DATA				
Rated Voltage (Volt)	115	230	115	230
Phase	1~	1~	1~	1~
Frequency (Hz)	50/60	50/60	50/60	50/60
Operating Range	+/- 10%	+/- 10%	+/- 10%	+/- 10%
Max power Consumption 50/60Hz L35 L35 (Watt)	810 / 1010	670 / 800	850 / 1040	850 / 1040
Max power Consumption 50/60Hz L35 L50 (Watt)	950 / 1120	780 / 950	990 / 1160	960 / 1170
Max. Nominal Current (Amps)	9.6 / 10.2	4.1 / 5.5	9.6 / 10.2	5.1 / 6.7
Starting Current (Amps)	32 / 34	14 / 18	32 / 34	17 / 22
Pre-fuse T (Amps)	15	15	15	15
Agency Approvals	UL Listed, cUL Listed, EAC, CE			
Power Input Description	Terminal Block			
PERFORMANCE FACTOR (EER), 50Hz, DIN EN 14511				
Cooling Performance L35 / L35	1.60 / 1.37	1.94 / 1.73	2.12 / 1.81	2.12 / 1.81
Cooling Performance L35 / L50	0.95 / 0.89	1.15 / 1.05	1.31 / 1.19	1.35 / 1.18
ENCLOSURE PROTECTION				
IP Code (External loop / Internal loop)	IP34 / IP54	IP34 / IP54	IP34 / IP54	IP34 / IP54
CONTROLLER				
Description	Smart Controller with display			
Controller Location	Ambient Side			
Factory Default Setpoint (°C Controller)	35	35	35	35
Factory Default Setpoint (°F Controller)	80	80	80	80
SOUND LEVEL				
At 1 M (dBA)	71	71	73	73
UNIT CONSTRUCTION				
Material	Steel		Steel	
Finish	RAL 7035		RAL 7035	
UNIT DIMENSIONS				
Height (mm)	950	950	950	950
Width (mm)	400	400	400	400
Depth (mm)	259	259	259	259
Weight (kg)	39	39	43	43

S10 UNIT CHARACTERISTICS (460V)

UNIT	1000W 460V	1500W 460v
CATALOG NUMBER		
Indoor Model without Communications Board (°C Controller)	S101046G031	S101546G031
Indoor Model with Communications Board (°C Controller)	S101046G041	S101546G041
Indoor Model without Communications Board (°F Controller)	S101046G050	S101546G050
Indoor Model with Communications Board (°F Controller)	S101046G060	S101546G060
COOLING PERFORMANCE		
Total L35 L35, 50Hz, according to DIN EN 14511 (Watt)	1300	1800
Cooling performance L35 L35 (Watt) 50/60Hz	1300 / 1380	1800 / 1880
Cooling performance L35 L50 (Watt) 50/60Hz	900 / 1000	1300 / 1380
Refrigerant	R134a	R134a
Refrigerant Charge (g)	283	510
Max. allowable operating pressure (p. max.) bar	28	28
Operating Temperature Range (Min/Max °C)	10 / 55	10 / 55
Operating Temperature Range (Min/Max °F)	50 / 131	50 / 131
Setting Temperature Range (Min. / Max. °C Controller)	20 / 55	20 / 55
Setting Temperature Range (Min. / Max. °F Controller)	72 / 120	72 / 120
Airflow at 0 Static Pressure:		
Internal loop (m³/h)	350 / 391	342 / 391
External loop (m³/h)	567 / 584	576 / 579
Duty Cycle	100%	100%
ELECTRICAL DATA		
Rated Voltage (Volt)	400 / 460	400 / 460
Phase	1~	3~
Frequency (Hz)	50/60	50/60
Operating Range	+/- 10%	+/- 10%
Max power Consumption 50/60Hz L35 L35 (Watt)	750 / 960	930 / 1130
Max power Consumption 50/60Hz L35 L50 (Watt)	870 / 1090	970 / 1210
Max. Nominal Current (Amps)	2.1 / 2.4	2.1 / 2.4
Starting Current (Amps)	7 / 8	7 / 8
Pre-fuse T (Amps)	15	15
Agency Approvals	UL Listed, cUL Listed, EAC, CE	
Power Input Description	Terminal Block	
PERFORMANCE FACTOR (EER), 50Hz, DIN EN 14511		
Cooling Performance L35 / L35	1.73 / 1.44	1.94 / 1.66
Cooling Performance L35 / L50	1.03 / 0.92	1.34 / 1.14
ENCLOSURE PROTECTION		
IP Code (External loop / Internal loop)	IP34 / IP54	IP34 / IP54
CONTROLLER		
Description	Smart Controller with display	
Controller Location	Ambient Side	
Factory Default Setpoint (°C Controller)	35	35
Factory Default Setpoint (°F Controller)	80	80
SOUND LEVEL		
At 1 M (dBA)	71	73
UNIT CONSTRUCTION		
Material	Steel	Steel
Finish	RAL 7035	RAL 7035
UNIT DIMENSIONS		
Height (mm)	950	950
Width (mm)	400	400
Depth (mm)	259	259
Weight (kg)	45	43

S10 COMPONENTS (1 PHASE)

Item	Model Series	1000W 115V	1000W 230V	1000W 460V	1500W 115V	1500W 230V
Part Descriptions		Part Numbers				
1	Capacitor, Compressor, Run	90235721SP	89107715SP	89107715SP	90235721SP	89107716SP
2	Capacitor, Condenser Blower	52603213SP	52603214SP	52603214SP	52603213SP	52603214SP
3	Capacitor, Evaporator Blower	52603215SP	52603214SP	52603214SP	52603215SP	52603214SP
4	Coil, Condenser	89102610SP	89102610SP	89102610SP	89102610SP	89102610SP
5	Coil, Evaporator	89102609SP	89102609SP	89102609SP	89102609SP	89102609SP
6	Communication Board (optional)	89109039SP	89109039SP	89109039SP	89109039SP	89109039SP
7	Compressor	89111874SP	89107239SP	89107239SP	89111874SP	89105607SP
8	Contacting Compressor	89088986SP	89088986SP	89088986SP	89088986SP	89088986SP
9	Smart Controller °C	89123540SP	89123540SP	89123540SP	89123540SP	89123540SP
	Smart Controller °F	90272220SP	90272220SP	90272220SP	90272220SP	90272220SP
10	Drain Tube Kit (optional)	101027177SP	101027177SP	101027177SP	101027177SP	101027177SP
11	Filter Air, Reusable (optional)	89106977SP	89106977SP	89106977SP	89106977SP	89106977SP
12	Filter/Dryer	52602800SP	52602800SP	52602800SP	52602800SP	52602800SP
13	Impeller, Condenser	89107374SP	89107375SP	89107375SP	89107374SP	89107375SP
14	Impeller, Evaporator	101091121SP	101091122SP	101091122SP	101091121SP	101091122SP
15	Thermal Expansion Valve	89063955SP	10104042SP	10104042SP	89063955SP	10104042SP
16	Thermal Overload, Compressor	90238424SP	89112628SP	89112628SP	90238424SP	NA
17	Thermistor	89075654SP (2)	89075654SP (2)	89075654SP (2)	89075654SP (2)	89075654SP (2)
18	Transformer, 24V	10100694SP	10100693SP	10100693SP	10100694SP	10100693SP
19	Transformer, 230/460V	NA	NA	101006111SP	NA	NA
20	Fuse (Controller)	89085114SP	89085114SP	89085114SP	89085114SP	89085114SP
Accessories						
21	Installation Kit	90221633QDSP	90221633QDSP	90221633QDSP	90221633QDSP	90221633QDSP
22	Unit Mounting Gasket	90241618SP	90241618SP	90241618SP	90241618SP	90241618SP
23	Mounting standoffs	89105489SP (4)	89105489SP (4)	89105489SP (4)	89105489SP (4)	89105489SP (4)
Structural Parts						
24	Louvered Grill Panel	89105410SP (2)	89105410SP (2)	89105410SP (2)	89105410SP (2)	89105410SP (2)
25	Controller Bezel Panel	89105411SP	89105411SP	89105411SP	89105411SP	89105411SP
26	Panel Strike Clip (Pkg. 4)	90245472SP	90245472SP	90245472SP	90245472SP	90245472SP
27	Body Catch Clip (Pkg. 4)	89105486SP	89105486SP	89105486SP	89105486SP	89105486SP
28	Body Front Shell	89102598SP	89102598SP	89102598SP	89102598SP	89102598SP

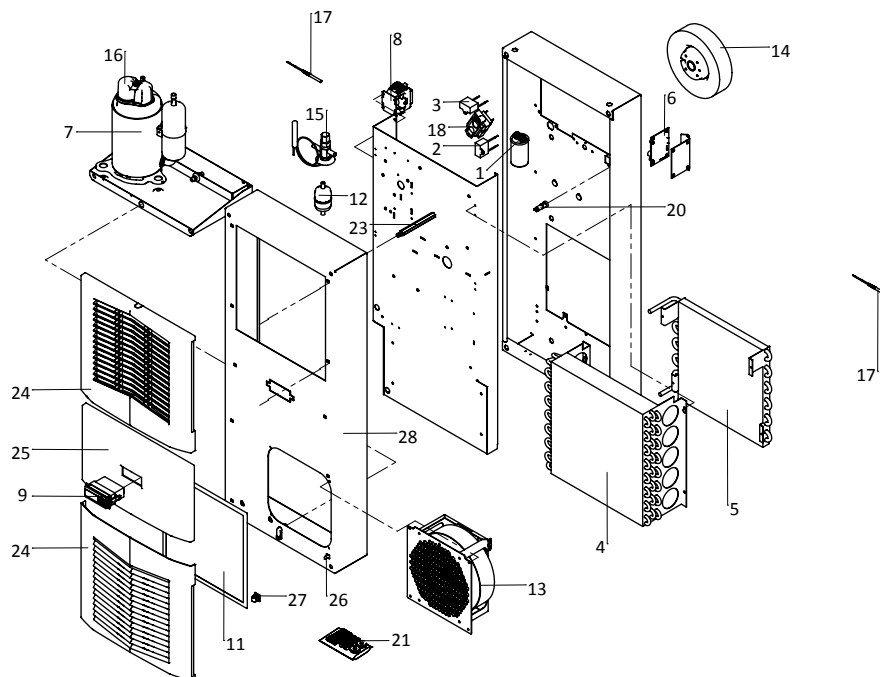

S10 COMPONENTS (3 PHASE)

Item	Model Series	1500W 460V
	Part Descriptions	Part Numbers
2	Capacitor, Condenser Blower	52603214SP
3	Capacitor, Evaporator Blower	52603214SP
4	Coil, Condenser	89108399SP
5	Coil, Evaporator	89102609SP
6	Communication Board (optional)	89109039SP
7	Compressor	89107888SP
8	Contactora Compressor	89107296SP
9	Smart Controller °C	89123540SP
	Smart Controller °F	90272220SP
10	Drain Tube Kit (optional)	101027177SP
11	Filter Air, Reusable (optional)	89106977SP
12	Filter/Dryer	52602800SP
13	Impeller, Condenser	89107375SP
14	Impeller, Evaporator	101091122SP
15	Thermal Expansion Valve	89063955SP
16	Thermal Overload, Compressor	90238425SP
17	Thermistor	89075654SP (2)
18	Transformer, 24V	10100693SP
19	Transformer, 460/230V	101006128SP
20	Fuse (Controller)	89085114SP
Accessories		
21	Installation Kit	90221633QDSP
22	Unit Mounting Gasket	90241618SP
23	Mounting standoffs	89105489SP (4)
Structural Parts		
24	Louvered Grill Panel	89105410SP (2)
25	Controller Bezel Panel	89105411SP
26	Panel Strike Clip (Pkg. 4)	90245472SP
27	Body Catch Clip (Pkg. 4)	89105486SP
28	Body Front Shell	89102598SP
29	Relay, Overload	89098323SP
30	Relay, Phase Monitor	89097986SP

S16 MODELS 2000/2500W

S16 SCHEMATICS

2000W 115V

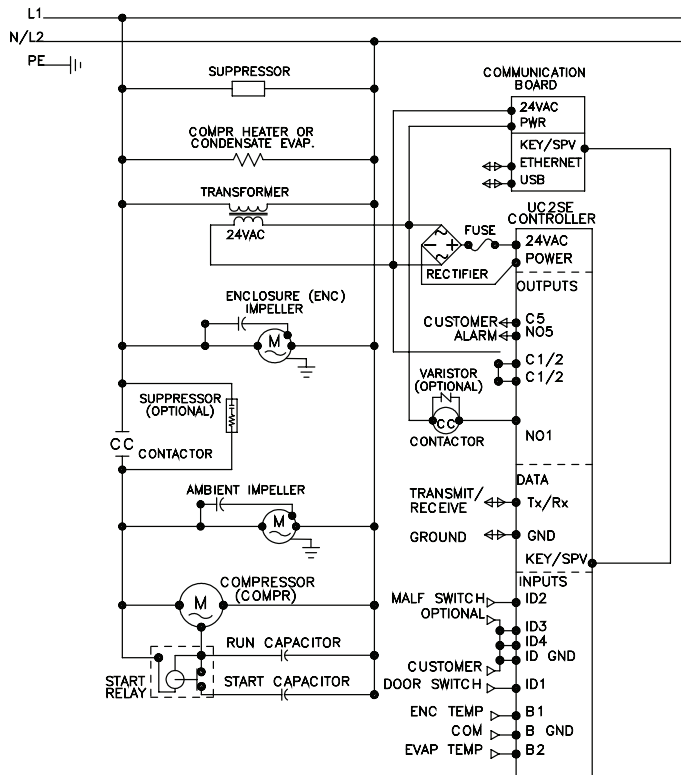

89116520 REV. B

ELECTRICAL SCHEMATIC

2000W 230V

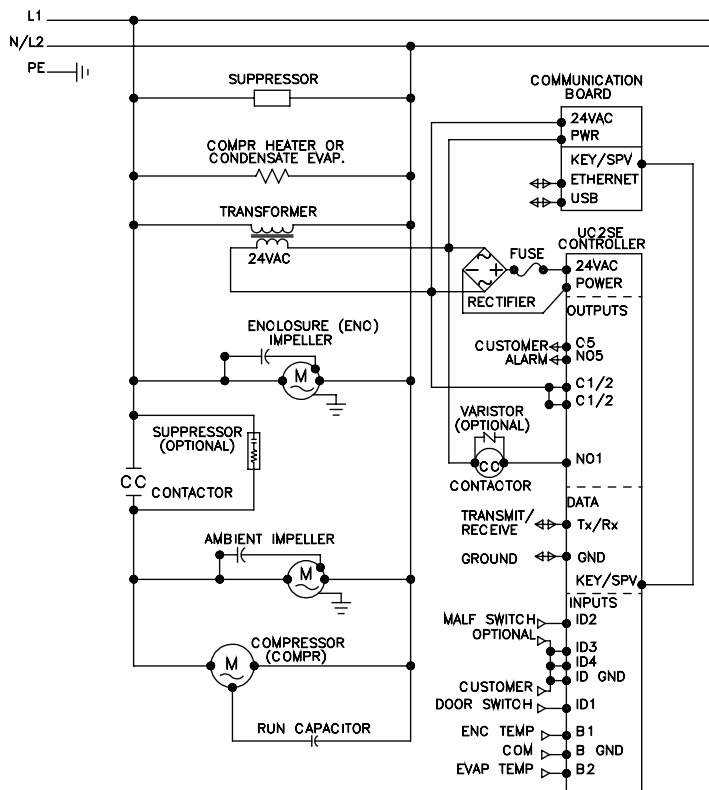

89107586 REV. G

ELECTRICAL SCHEMATIC

2000W 460V

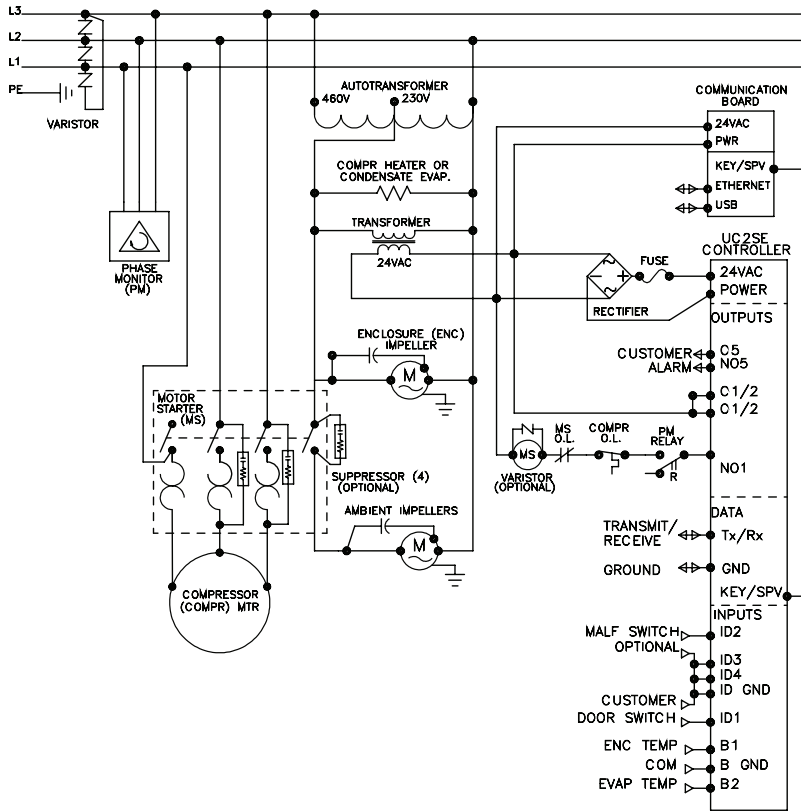

89107589 REV. H

ELECTRICAL SCHEMATIC

2500W 115V

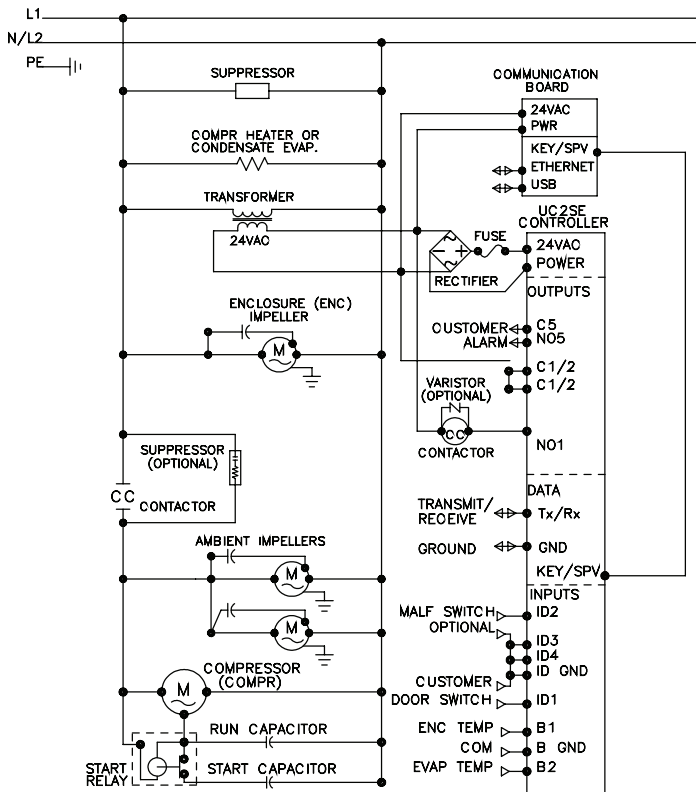

89116522 REV. B

ELECTRICAL SCHEMATIC

2500W 230V

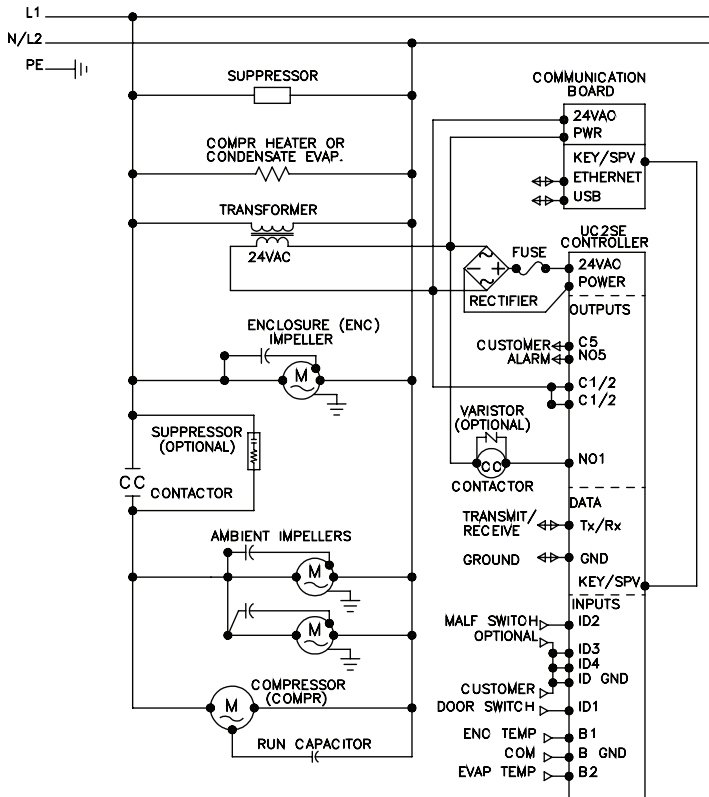

89107591 REV. G

ELECTRICAL SCHEMATIC

2500W 460V

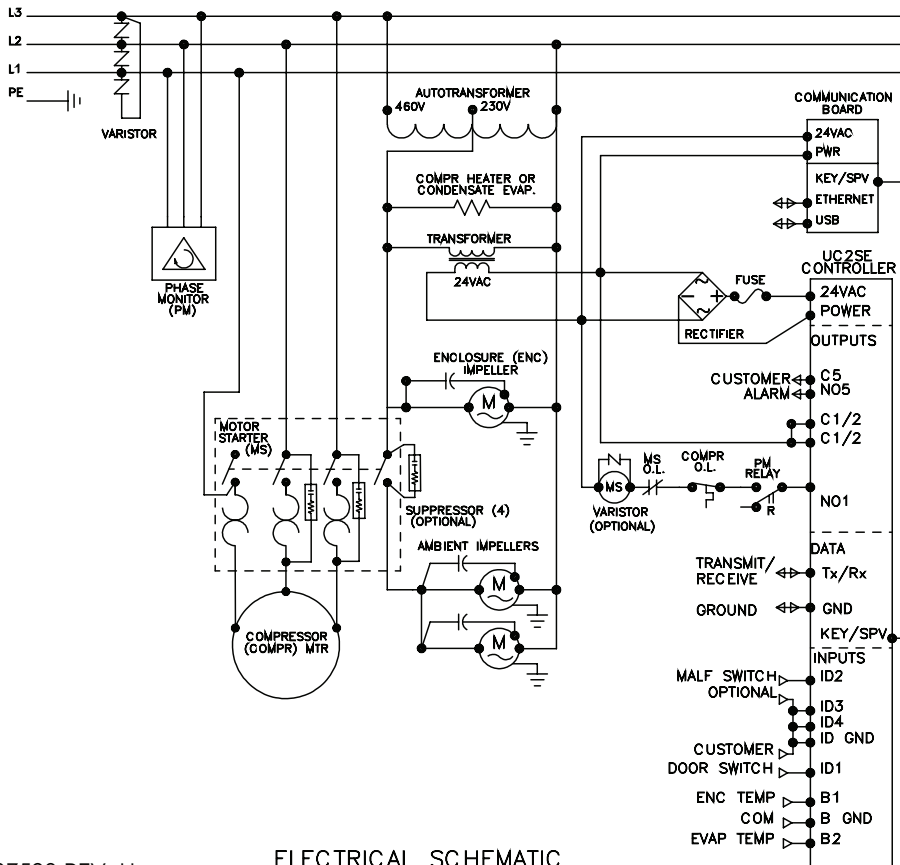

89107593 REV. H

ELECTRICAL SCHEMATIC

4000W 460V

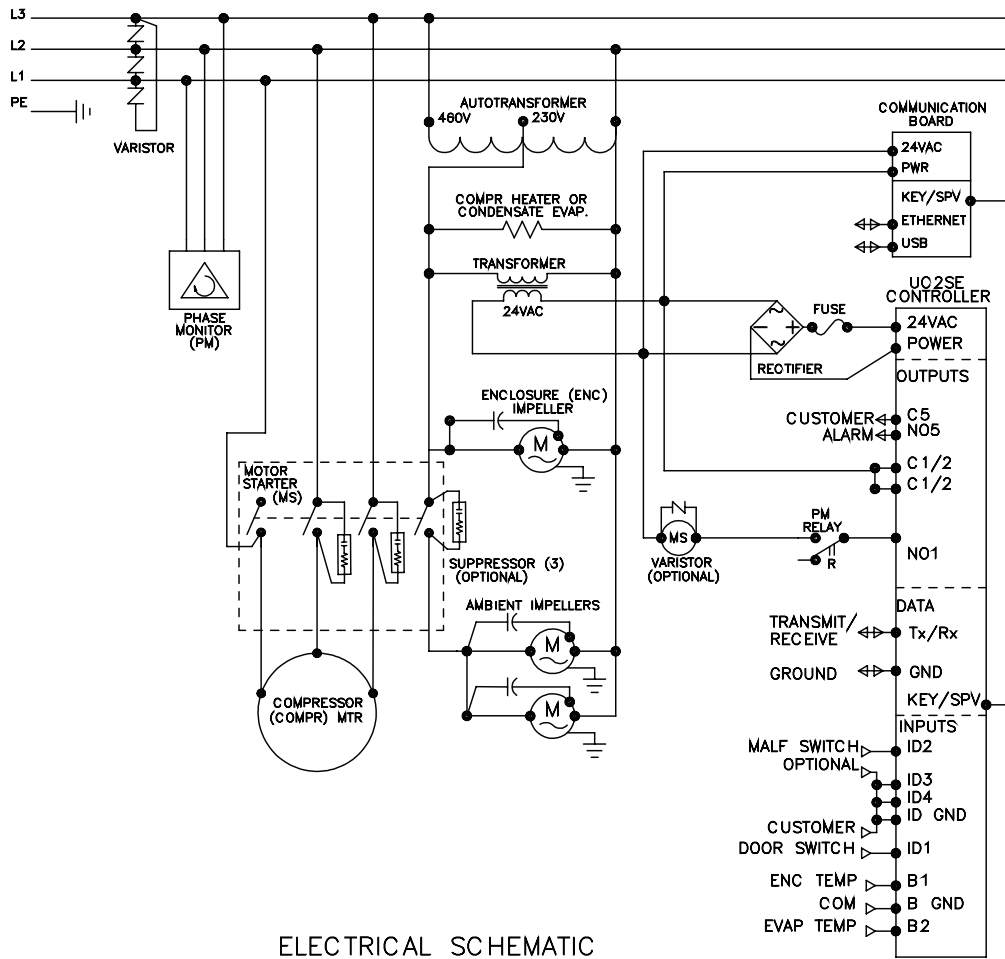

89107595 REV. G

S16 WIRE DIAGRAMS

2000W 115V

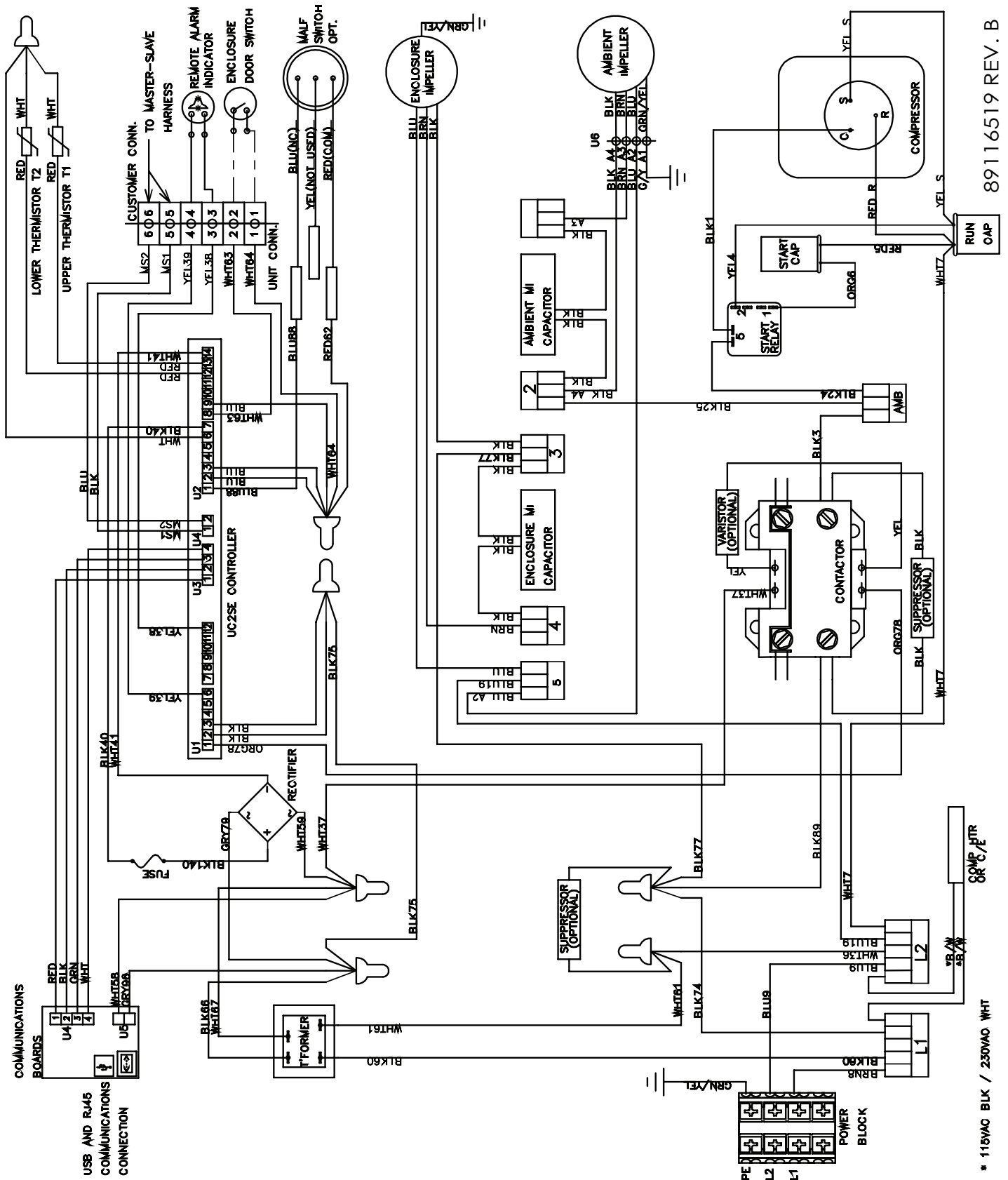

89116519 REV. B

* 115VAC BLK / 230VAC WHT

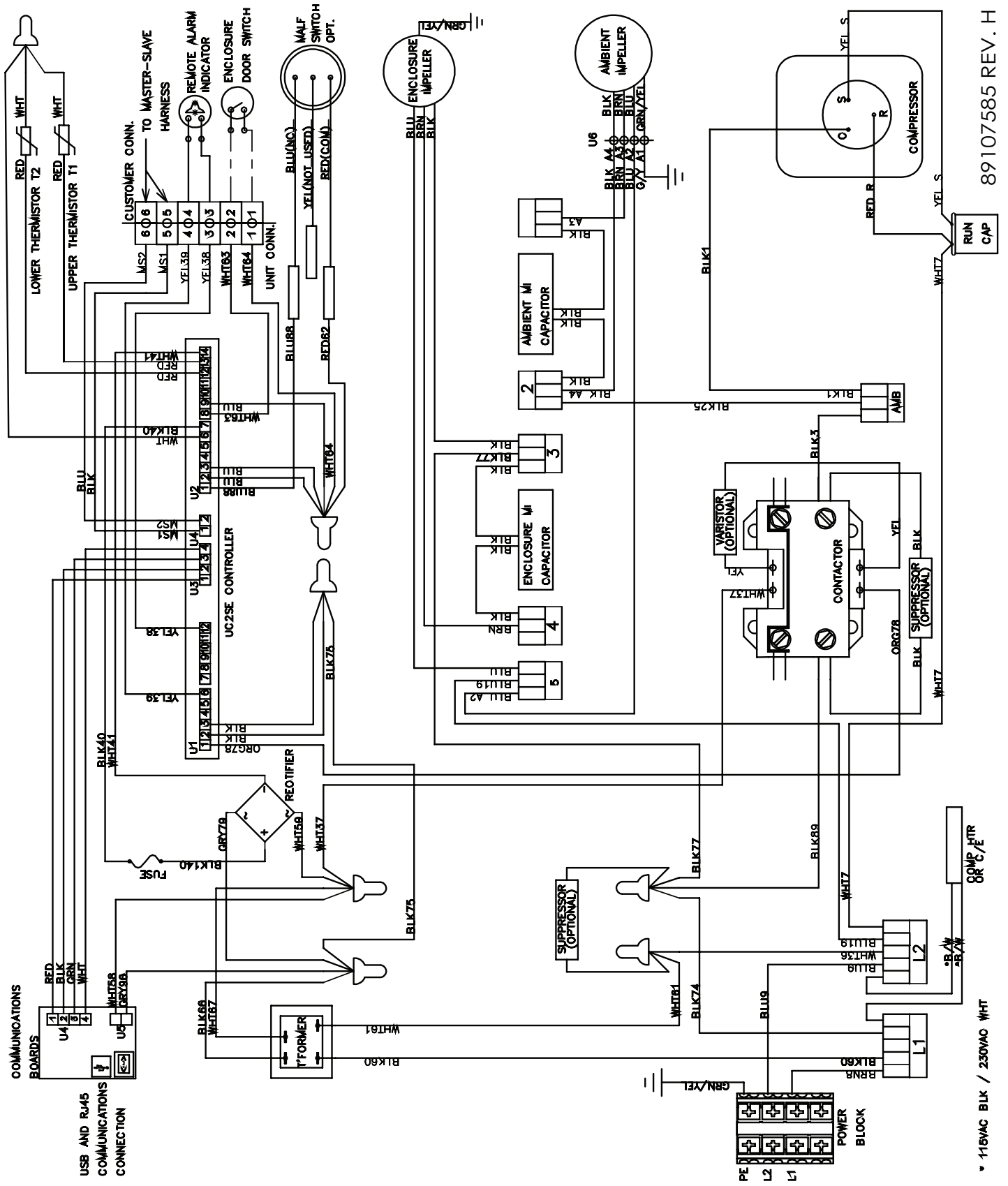

89107585 REV. H

* 115VAC BLK / 230VAC WHT

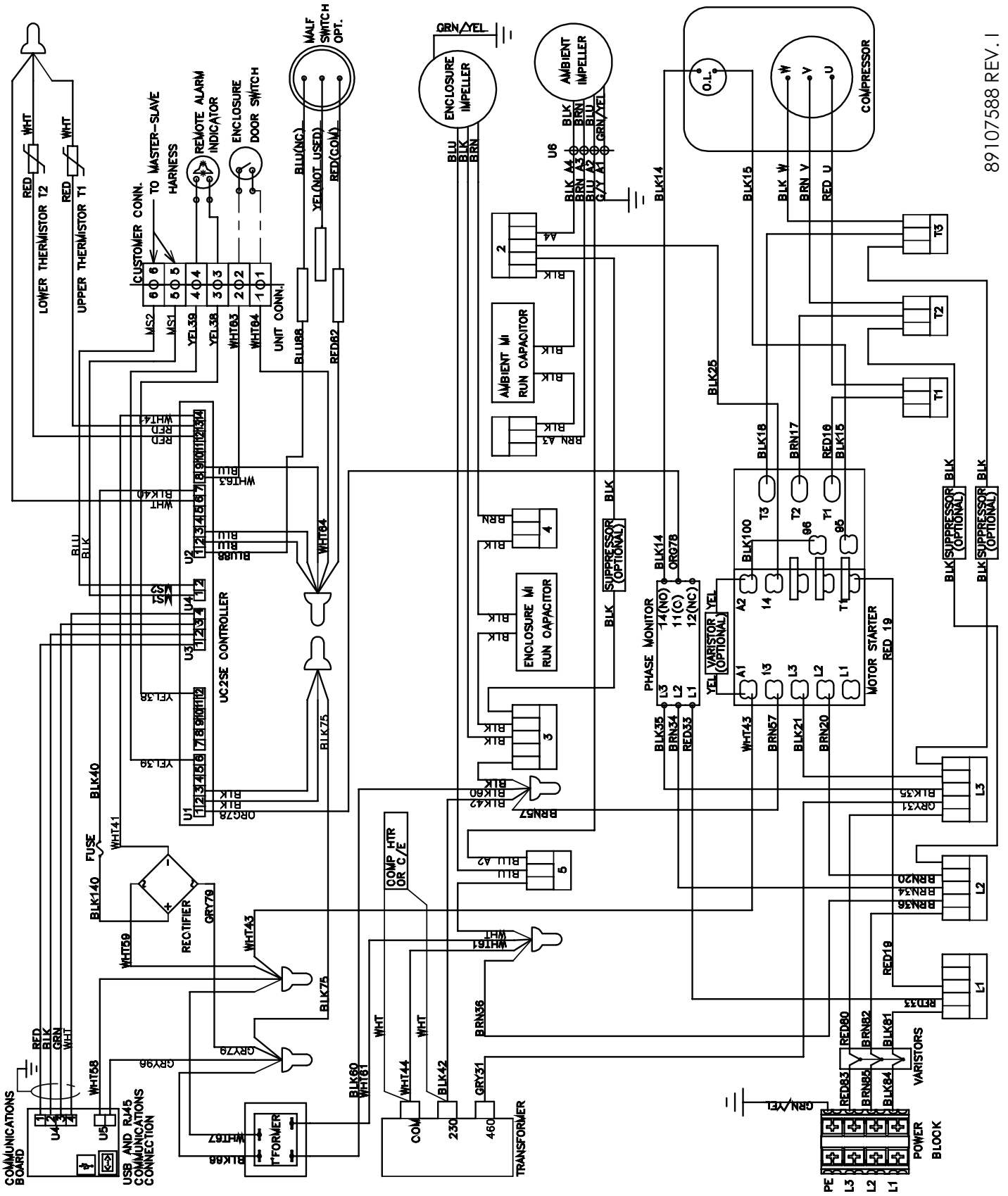

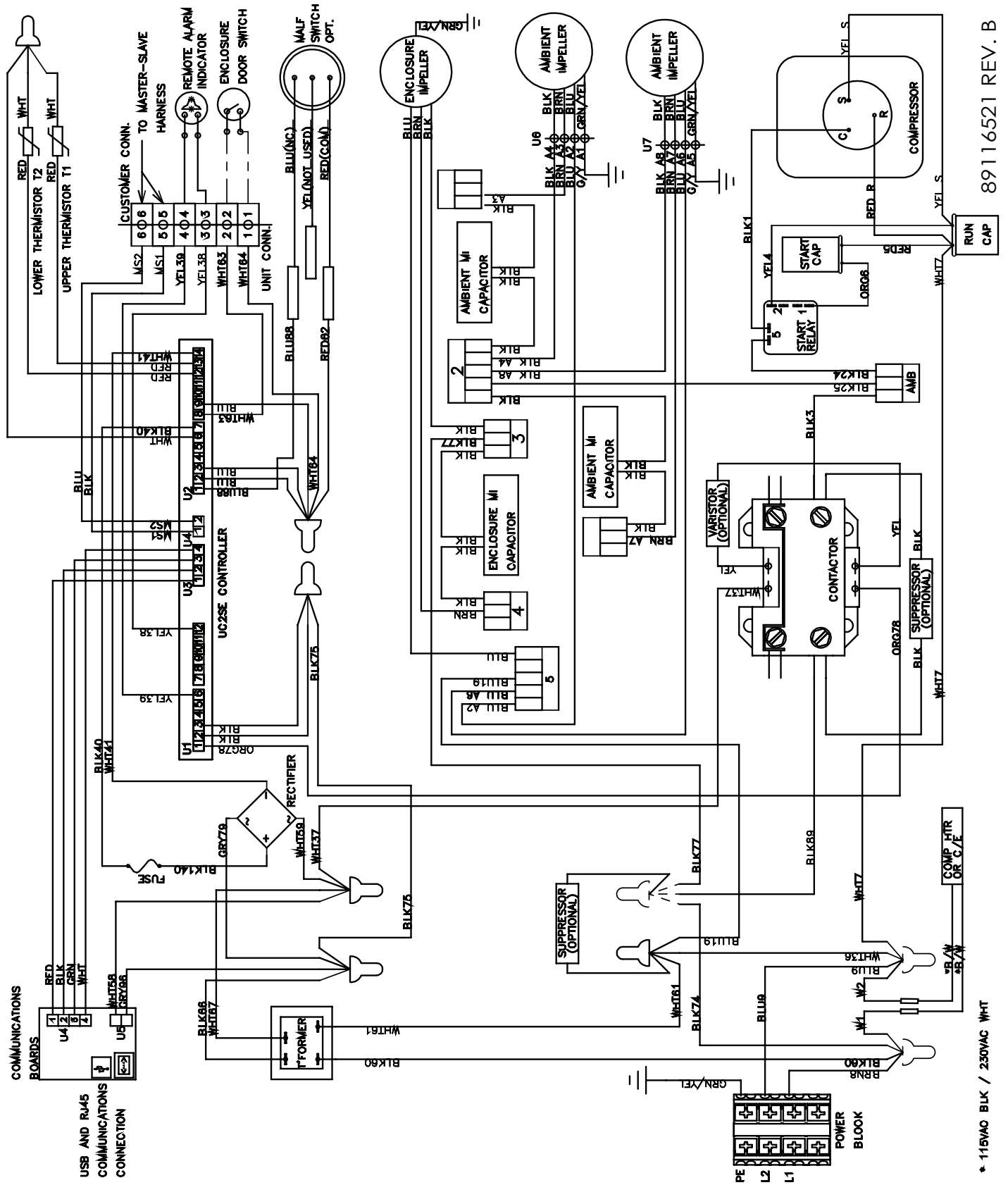

89116521 REV. B

* 115VAC BLK / 230VAC WHT

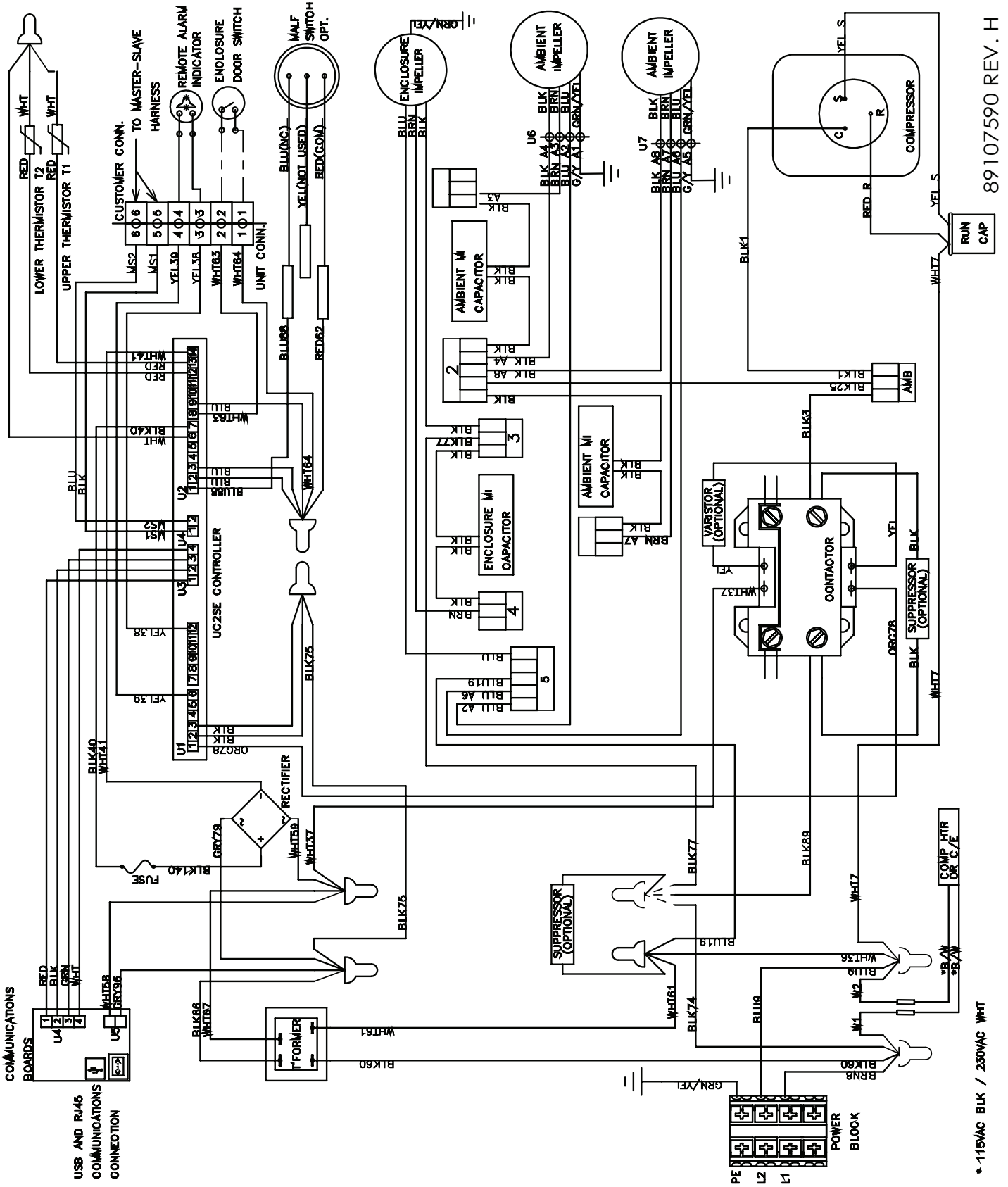

89107590 REV. H

*-115VAC BLK / 250VAC WHT

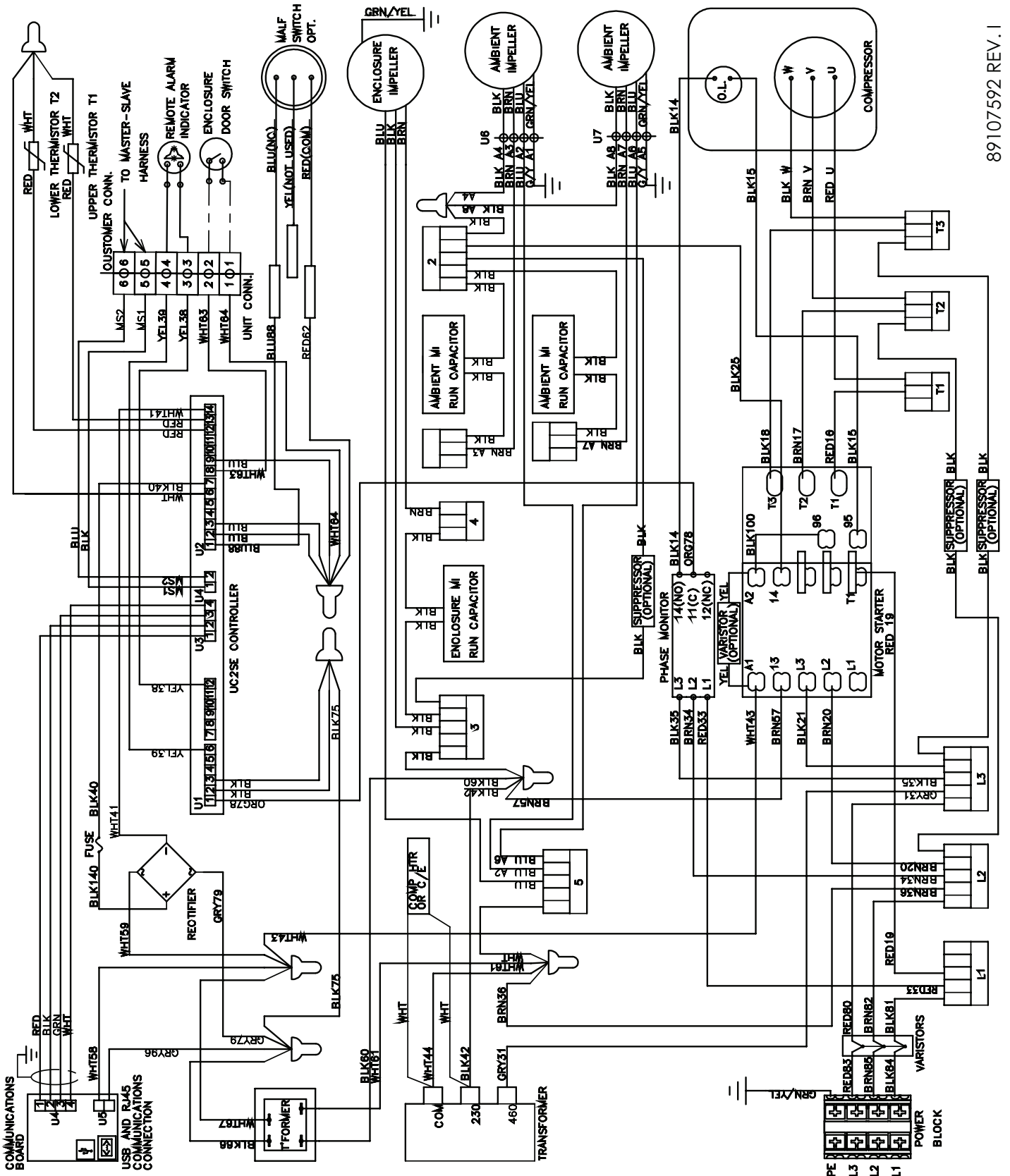

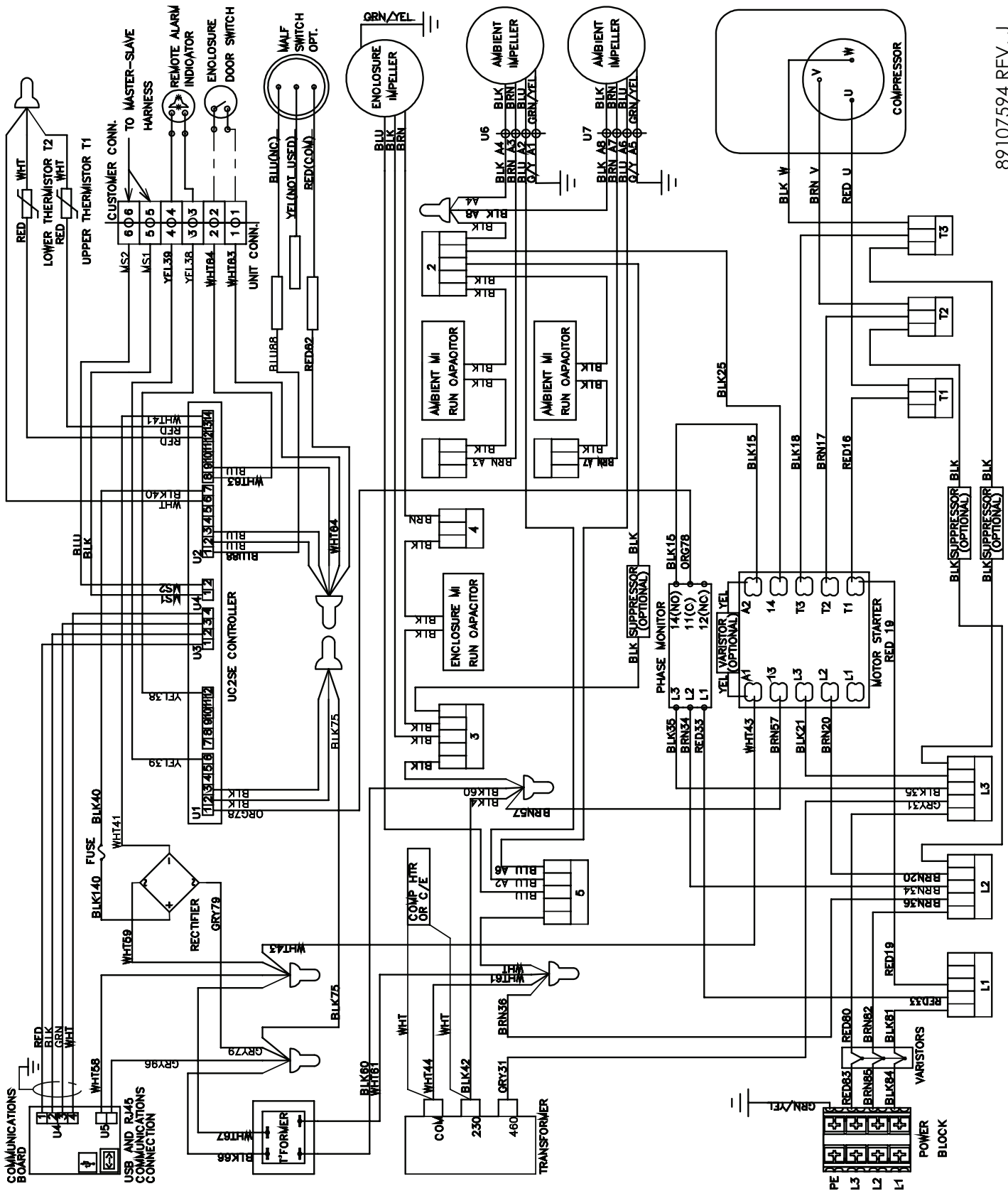

S16 DIMENSIONAL DRAWING 2000/2500W

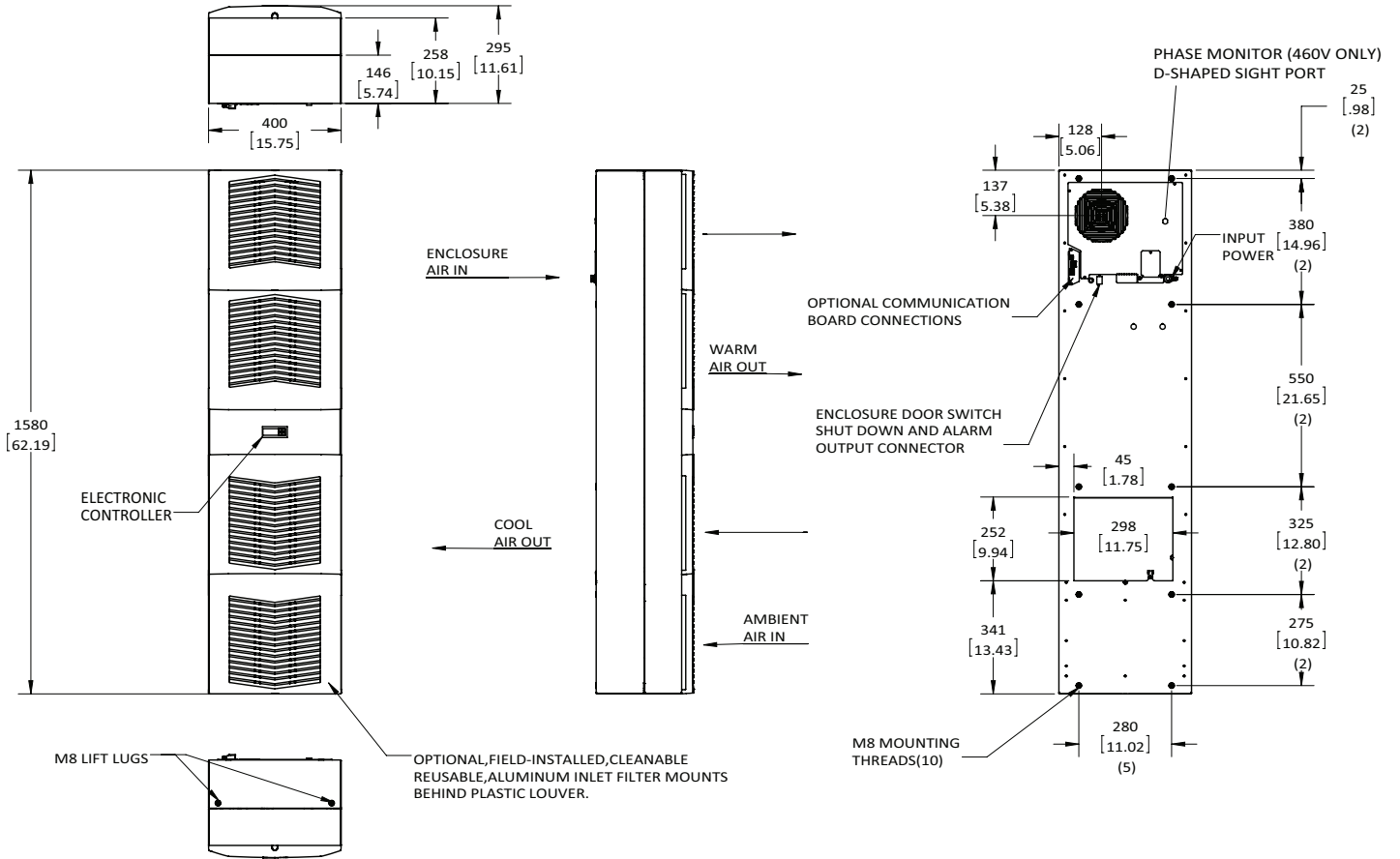

4000W

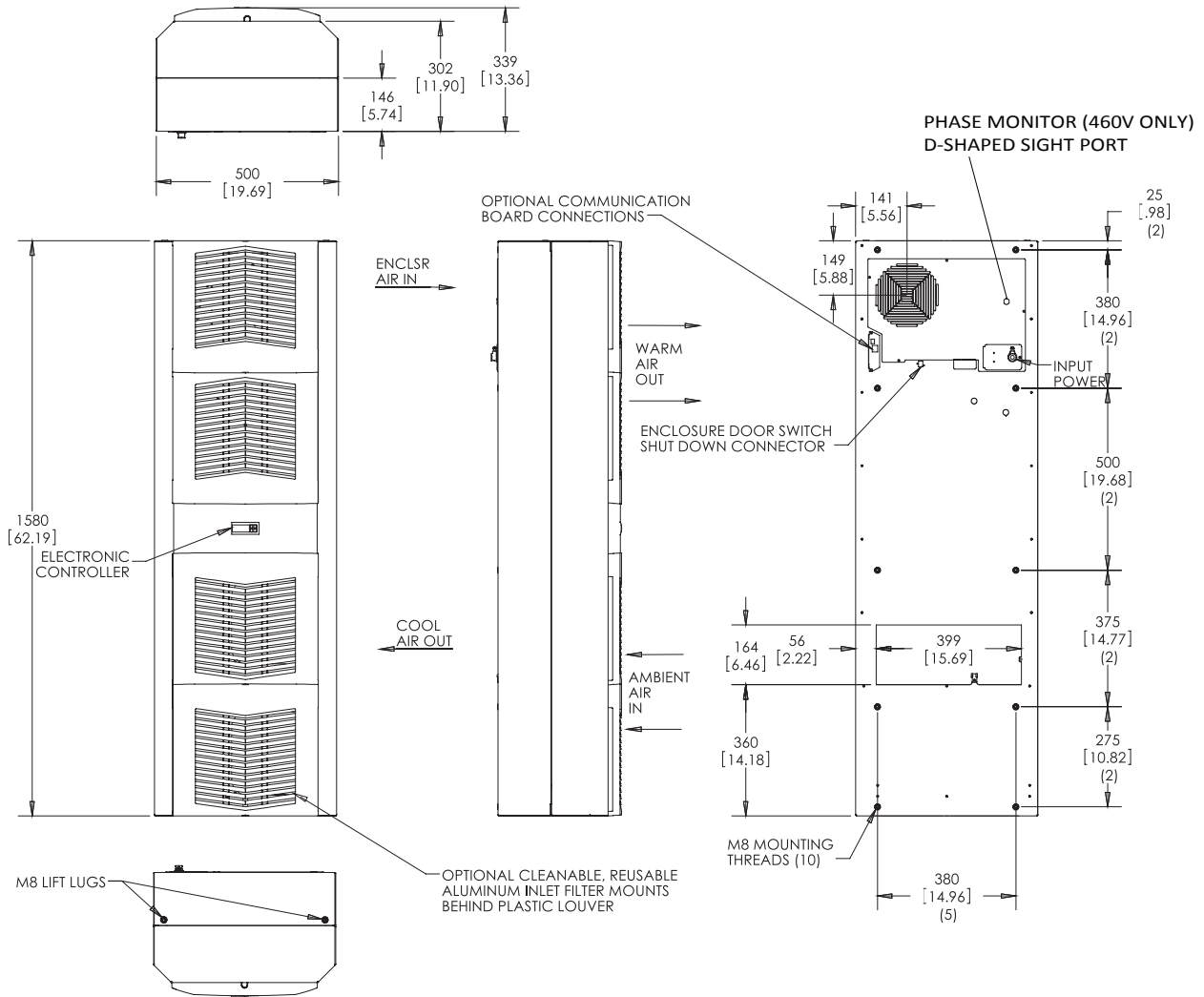

S16 INSTALLATION INSTRUCTION

1. See Receiving The Air Conditioner and Handling and Testing The Air Conditioner on page 6.
2. Using the cutout template provided with the unit, prepare the enclosure. See Figure 16 and Figure 17. The front of the unit requires a half meter clearance for proper airflow. Five centimeters is required on each side of the unit. To avoid condensate overflow, unit must be mounted within 3° of level.
3. Refer to mounting instructions on page 8.
4. Adjust controller to desired cabinet temperature. Refer to Displaying and Changing Program Variables on page 13 for controller adjustment and operation.

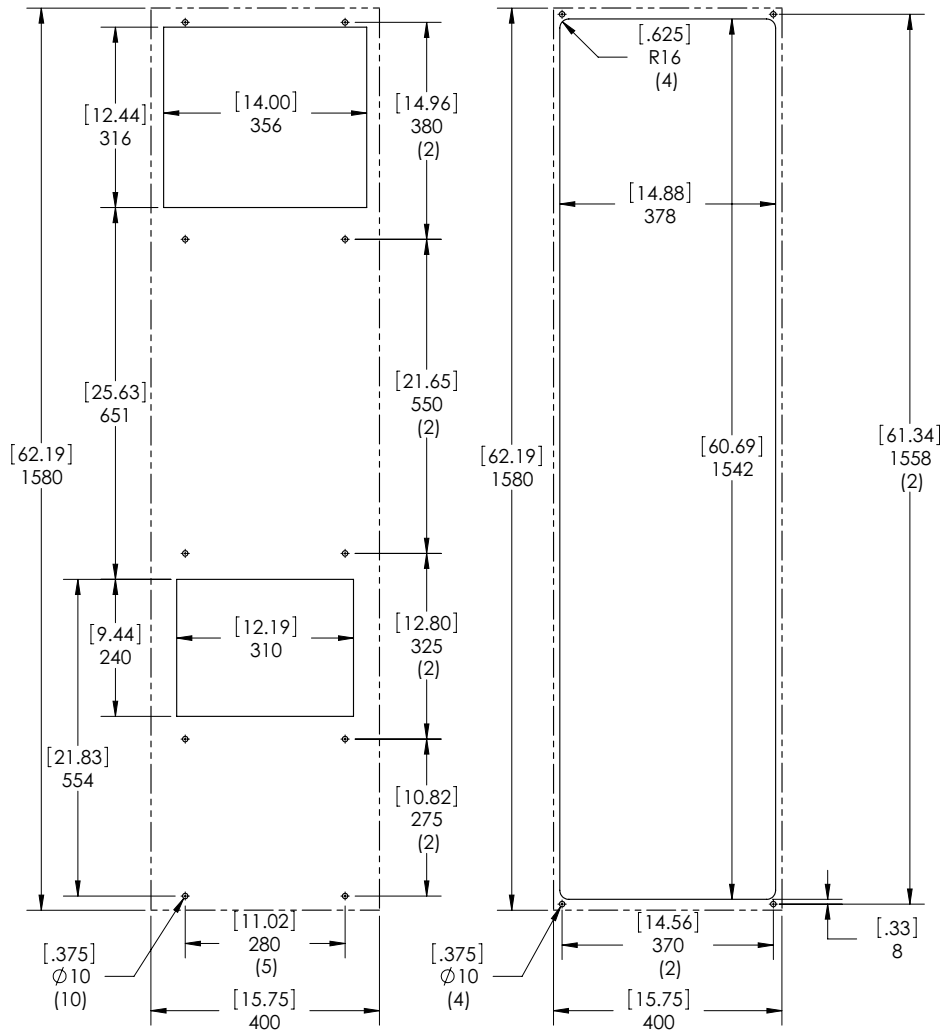

Surface Mount

Partial and Full Recess Mount

Figure 16
S16 2000/2500W Cutout Drawing
 Dashed Lines Represent The Air Conditioner

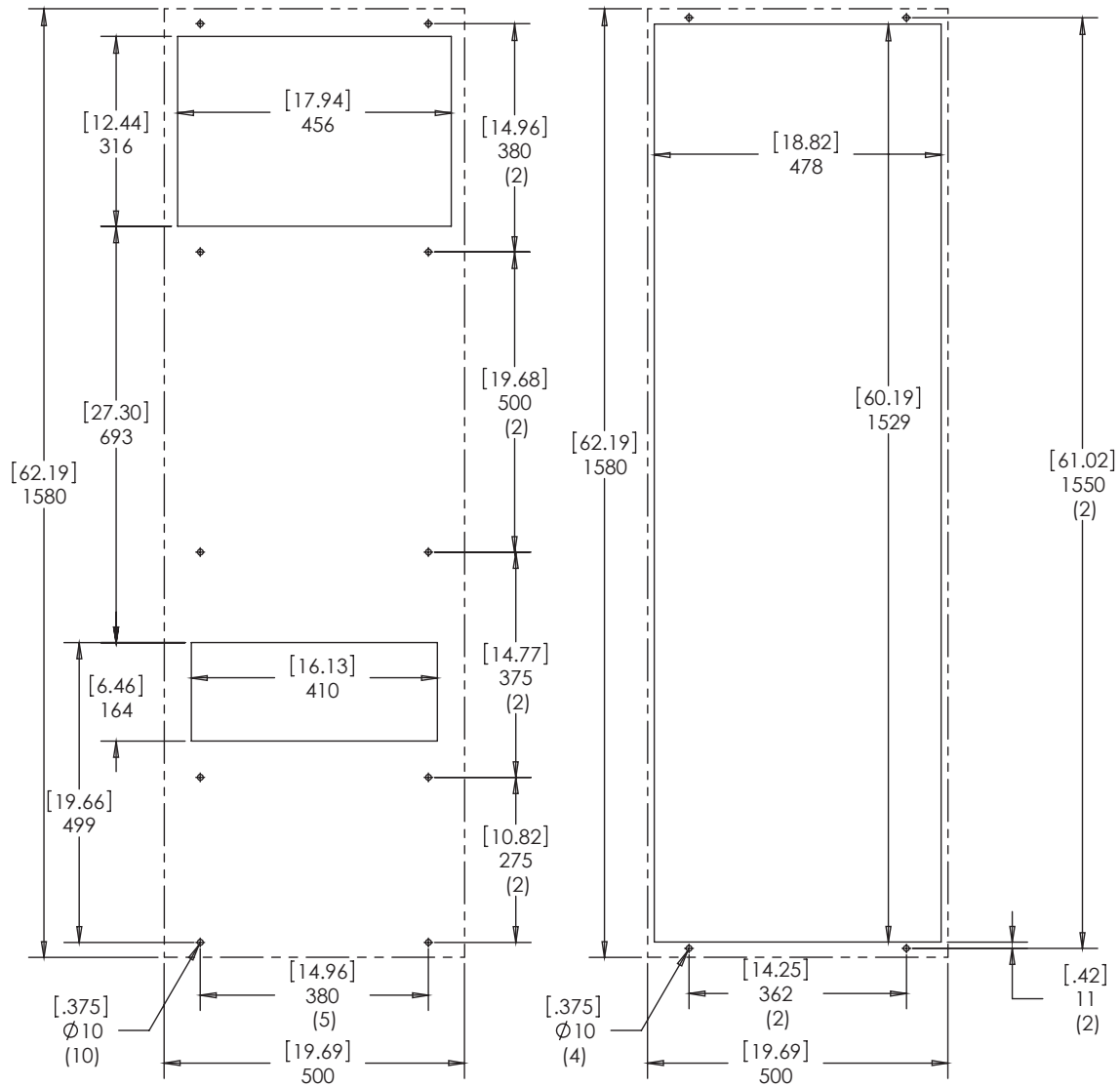

Surface Mount

Partial Recess Mount

Figure 17
S16 4000W Cutout Drawing
 Dashed Lines Represent The Air Conditioner

S16 UNIT CHARACTERISTICS (115V, 230V)

UNIT	2000W 115V	2000W 230V	2500W 115V	2500W 230V
CATALOG NUMBER				
Indoor Model without Communications Board (°C Controller)	S162016G031	S162026G031	S162516G031	S162526G031
Indoor Model with Communications Board (°C Controller)	S162016G041	S162026G041	S162516G041	S162526G041
Indoor Model without Communications Board (°F Controller)	S162016G050	S162026G050	S162516G050	S162526G050
Indoor Model with Communications Board (°F Controller)	S162016G060	S162026G060	S162516G060	S162526G060
COOLING PERFORMANCE				
Total L35 L35, 50Hz, according to DIN EN 14511 (Watt)	2200	2200	2680	2680
Cooling performance L35 L35 (Watt) 50/60Hz	2200 / 2400	2200 / 2400	2680 / 2800	2680 / 2800
Cooling performance L35 L50 (Watt) 50/60Hz	1820 / 1900	1820 / 1900	2200 / 2300	2200 / 2300
Refrigerant	R134a	R134a	R134a	R134a
Refrigerant Charge (g)	709	709	737	737
Max. allowable operating pressure (p. max.) bar	28	28	28	28
Operating Temperature Range (Min/Max °C)	10 / 55	10 / 55	10 / 55	10 / 55
Operating Temperature Range (Min/Max °F)	50 / 131	50 / 131	50 / 131	50 / 131
Setting Temperature Range (Min. / Max. °C Controller)	20 / 55	20 / 55	20 / 55	20 / 55
Setting Temperature Range (Min. / Max. °F Controller)	72 / 120	72 / 120	72 / 120	72 / 120
Airflow at 0 Static Pressure:				
Internal loop (m³/h)	454 / 484	454 / 484	447 / 466	447 / 466
External loop (m³/h)	634 / 654	634 / 654	1104 / 1143	1104 / 1143
Duty Cycle	100%	100%	100%	100%
ELECTRICAL DATA				
Rated Voltage (Volt)	115	230	115	230
Phase	1~	1~	1~	1~
Frequency (Hz)	50/60	50/60	50/60	50/60
Operating Range	+/- 10%	+/- 10%	+/- 10%	+/- 10%
Max power Consumption 50/60Hz L35 L35 (Watt)	930 / 1090	940 / 1140	1230 / 1420	1320 / 1650
Max power Consumption 50/60Hz L35 L50 (Watt)	1280 / 1410	1070 / 1320	1500 / 1970	1500 / 1910
Max. Nominal Current (Amps)	11.1 / 12.5	5.7 / 7.2	16.1 / 16.9	8.0 / 10.1
Starting Current (Amps)	37 / 41	19 / 24	53 / 56	26 / 33
Pre-fuse T (Amps)	15	15	20	15
Agency Approvals	UL Listed, cUL Listed, EAC, CE			
Power Input Description	Terminal Block			
PERFORMANCE FACTOR (EER), 50Hz, DIN EN 14511				
Cooling Performance L35 / L35	2.37 / 2.20	2.34 / 2.11	2.18 / 1.97	2.03 / 1.70
Cooling Performance L35 / L50	1.42 / 1.35	1.70 / 1.44	1.47 / 1.17	1.47 / 1.20
ENCLOSURE PROTECTION				
IP Code (External loop / Internal loop)	IP34 / IP54	IP34 / IP54	IP34 / IP54	IP34 / IP54
CONTROLLER				
Description	Smart controller with display			
Controller Location	Ambient Side			
Factory Default Setpoint (°C Controller)	35	35	35	35
Factory Default Setpoint (°F Controller)	80	80	80	80
SOUND LEVEL				
At 1 M (dBA)	70	70	72	72
UNIT CONSTRUCTION				
Material	Steel		Steel	
Finish	RAL 7035		RAL 7035	
UNIT DIMENSIONS				
Height (mm)	1580	1580	1580	1580
Width (mm)	400	400	400	400
Depth (mm)	295	295	295	295
Weight (kg)	68	68	70	70

S16 UNIT CHARACTERISTICS (460V)

UNIT	2000W 460V	2500W 460V	4000W 460V
CATALOG NUMBER			
Indoor Model without Communications Board (°C Controller)	S162046G031	S162546G031	S164046G031
Indoor Model with Communications Board (°C Controller)	S162046G041	S162546G041	S164046G041
Indoor Model without Communications Board (°F Controller)	S162046G050	S162546G050	S164046G050
Indoor Model with Communications Board (°F Controller)	S162046G060	S162546G060	S164046G060
COOLING PERFORMANCE			
Total L35 L35, 50Hz, according to DIN EN 14511 (Watt)	2200	2680	4000
Cooling performance L35 L35 (Watt) 50/60Hz	2200 / 2400	2680 / 2800	4000 / 4500
Cooling performance L35 L50 (Watt) 50/60Hz	1820 / 1900	2200 / 2300	3050 / 3450
Refrigerant	R134a	R134a	R134a
Refrigerant Charge (g)	709	850	1247
Max. allowable operating pressure (p. max.) bar	28	28	28
Operating Temperature Range (Min/Max °C)	10 / 55	10 / 55	10 / 55
Operating Temperature Range (Min/Max °F)	50 / 131	50 / 131	50 / 131
Setting Temperature Range (Min. / Max. °C Controller)	20 / 55	20 / 55	20 / 55
Setting Temperature Range (Min. / Max. °F Controller)	72 / 120	72 / 120	72 / 120
Airflow at 0 Static Pressure:			
Internal loop (m³/h)	454 / 484	447 / 466	494 / 576
External loop (m³/h)	634 / 654	1104 / 1143	1070 / 1184
Duty Cycle	100%	100%	100%
ELECTRICAL DATA			
Rated Voltage (Volt)	400 / 460	400 / 460	400 / 460
Phase	3~	3~	3~
Frequency (Hz)	50/60	50/60	50/60
Operating Range	+/- 10%	+/- 10%	+/- 10%
Max power Consumption 50/60Hz L35 L35 (Watt)	900 / 1180	1150 / 1510	1790 / 2310
Max power Consumption 50/60Hz L35 L50 (Watt)	1060 / 1340	1330 / 1770	1850 / 2430
Max. Nominal Current (Amps)	2.2 / 2.6	3.2 / 3.4	4.2 / 4.4
Starting Current (Amps)	7 / 9	11 / 11	14 / 15
Pre-fuse T (Amps)	15	15	15
Agency Approvals	UL-listed, cUL-listed, EAC, CE		
Power Input Description	Terminal Block		
PERFORMANCE FACTOR (EER), 50Hz, DIN EN 14511			
Cooling Performance L35 / L35	2.44 / 2.03	2.33 / 1.85	2.23 / 1.95
Cooling Performance L35 / L50	1.72 / 1.42	1.65 / 1.30	1.65 / 1.42
ENCLOSURE PROTECTION			
IP Code (External loop / Internal loop)	IP34 / IP54	IP34 / IP54	IP34 / IP54
CONTROLLER			
Description	Smart controller with display		
Controller Location	Ambient side		
Factory Default Setpoint (°C Controller)	35	35	35
Factory Default Setpoint (°F Controller)	80	80	80
SOUND LEVEL			
At 1 M (dBA)	70	72	72
UNIT CONSTRUCTION			
Material	Steel		
Finish	RAL 7035		
UNIT DIMENSIONS			
Height (mm)	1580	1580	1580
Width (mm)	400	400	500
Depth (mm)	295	295	340
Weight (kg)	68	70	92

S16 COMPONENTS (115V, 230V)

Item	Model Series	2000W 115V	2000W 230V	2500W 115V	2500W 230V
Part Descriptions		Part Numbers			
1	Capacitor, Compressor, Run	89107716SP	89107716SP	89107712	89107712SP
2	Capacitor, Compressor, Start	10103208SP	NA	10103232SP	NA
3	Capacitor, Condenser Blower	52603213SP	52603214SP	52603213SP (2)	52603214SP (2)
4	Capacitor, Evaporator Blower	52603213SP	52603214SP	52603213SP	52603214SP
5	Coil, Condenser	89107341SP	89107341SP	89107341SP	89107341SP
6	Coil, Evaporator	89110233SP	89110233SP	89110233SP	89110233SP
7	Communication Board (optional)	89109039SP	89109039SP	89109039SP	89109039SP
8	Compressor	10101685SP	89107887SP	10101688SP	89107889SP
9	Contacting Compressor	89088986SP	89088986SP	89088986SP	89088986SP
10	Smart Controller °C	89123540SP	89123540SP	89123540SP	89123540SP
	Smart Controller °F	90272220SP	90272220SP	90272220SP	90272220SP
11	Drain Tube Kit (optional)	101027177SP	101027177SP	101027177SP	101027177SP
12	Filter Air, Reusable (optional)	89106977SP	89106977SP	89106977SP (2)	89106977SP (2)
13	Filter/Dryer	52602800SP	52602800SP	52602800SP	52602800SP
14	Impeller, Condenser	89107374SP	89107375SP	89107374SP (2)	89107375SP (2)
15	Impeller, Evaporator	101091123SP	101091124SP	101091123SP	101091124SP
16	Relay, Compressor Start	89105934SP	NA	89105936SP	NA
17	Thermal Expansion Valve	10104038SP	10104038SP	89114096SP	10104038SP
18	Thermal Overload, Compressor	10100773SP	NA	NA	NA
19	Thermistor	89075654SP (2)	89075654SP (2)	89075654SP (2)	89075654SP (2)
20	Transformer, 24V	10100694SP	10100693SP	10100694SP	10100693SP
21	Fuse (Controller)	89085114SP	89085114SP	89085114SP	89085114SP
Accessories					
22	Installation Kit	90221632QDSP	90221632QDSP	90221632QDSP	90221632QDSP
23	Unit Mounting Gasket	90241619SP	90241619SP	90241619SP	90241619SP
24	Mounting standoffs	89105490SP (4)	89105490SP (4)	89105490SP (4)	89105490SP (4)
Structural Parts					
25	Louvered Grill Panel	89105410SP (4)	89105410SP (4)	89105410SP (4)	89105410SP (4)
26	Controller Bezel Panel	89105411SP	89105411SP	89105411SP	89105411SP
27	Panel Strike Clip (Pkg. 4)	90245472SP	90245472SP	90245472SP	90245472SP
28	Body Catch Clip (Pkg. 4)	89105486SP	89105486SP	89105486SP	89105486SP
29	Body Front Shell	89107454SP	89107454SP	89102801SP	89102801SP

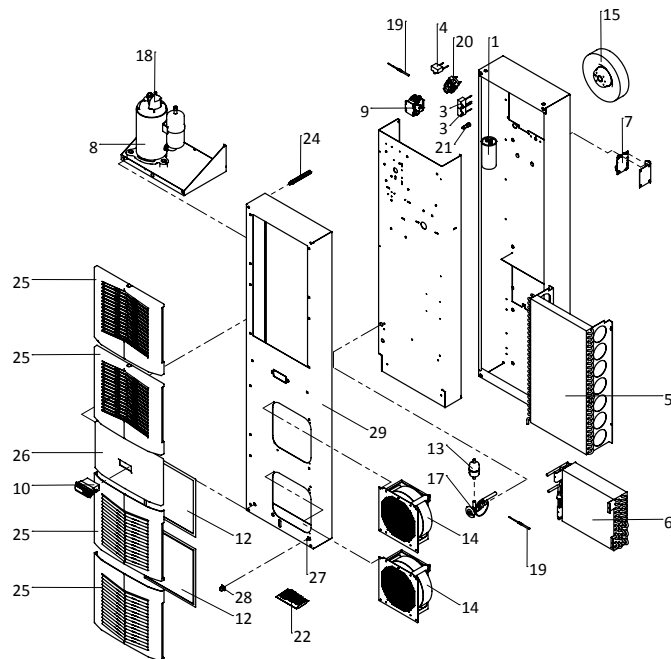

S16 COMPONENTS (460V)

Item	Model Series	2000W 460V	2500W 460V	4000W 460V
	Part Descriptions	Part Numbers		
3	Capacitor, Condenser Blower	52603214SP	52603214SP (2)	52603214SP (2)
4	Capacitor, Evaporator Blower	52603214SP	52603214SP	52603220SP
5	Coil, Condenser	89107341SP	89107341SP	89108064SP
6	Coil, Evaporator	89110233SP	89110233SP	89115695SP
7	Communication Board (optional)	89109039SP	89109039SP	89109039SP
8	Compressor	89107888SP	89107890SP	89107934SP
9	Contacto Compressor	89107296SP	89107296SP	89107296SP
10	Smart Controller °C	89123540SP	89123540SP	89123540SP
	Smart Controller °F	90272220SP	90272220SP	90272220SP
11	Drain Tube Kit (optional)	101027177SP	101027177SP	101027177SP
12	Filter Air, Reusable (optional)	89106977SP	89106977SP (2)	89106977SP (2)
13	Filter/Dryer	52602800SP	52602800SP	52602806SP
14	Impeller, Condenser	89107375SP	89107375SP (2)	89107375SP (2)
15	Impeller, Evaporator	101091124SP	101091124SP	101091139SP
16	Relay, Overload	89098323SP	89098326SP	NA
17	Thermal Expansion Valve	89117868SP	10104038SP	89114096SP
18	Thermal Overload, Compressor	90238425SP	90238425SP	NA
19	Thermistor	89075654SP (2)	89075654SP (2)	89075654SP (2)
20	Transformer, 24V	10100693SP	10100693SP	10100693SP
21	Fuse (Controller)	89085114SP	89085114SP	89085114SP
Accessories				
22	Installation Kit	90221632QDSP	90221632QDSP	90221632QDSP
23	Unit Mounting Gasket	90241619SP	90241619SP	90241620SP
24	Mounting standoffs	89105490SP (4)	89105490SP (4)	89105491SP (4)
Structural Parts				
25	Louvered Grill Panel	89105410SP (4)	89105410SP (4)	89105410SP (4)
26	Controller Bezel Panel	89105411SP	89105411SP	89105411SP
27	Panel Strike Clip (Pkg. 4)	90245472SP	90245472SP	90245472SP
28	Body Catch Clip (Pkg. 4)	89105486SP	89105486SP	89105486SP
29	Body Front Shell	89107454SP	89102801SP	89104006SP
30	Transformer, 460/230V	101006128SP	101006128SP	101006128SP
31	Relay, Phase Monitor	89097986SP	89097986SP	89097986SP

MAINTENANCE COMPRESSOR

The compressor requires no maintenance. It is hermetically sealed, properly lubricated at the factory and should provide years of satisfactory operating service.

INLET AIR FILTER (FIELD INSTALLED OPTION)

This air conditioner was designed with a dust resistant condenser coil. This allows it to be run filterless in most applications. Should you decide the filter is necessary in your application, regular maintenance to clean this filter will assure normal operation of the air conditioner. The easily removable inlet air filter is located behind the louvered grille. If necessary filter maintenance is delayed or ignored, the maximum ambient temperatures under which the unit is designed to operate will be decreased.

If the compressor's operating temperature increases above designed conditions due to a dirty or clogged filter (or plugged condenser coil), the air conditioner's compressor will stop operating due to actuation of the thermal overload cut-out switch located on the compressor housing. As soon as the compressor temperature has dropped to within the switch's cut-in setting, the compressor will restart automatically. However the above condition will continue to take place until the filter or coil has been cleaned. It is recommended that power to the air conditioner be interrupted intentionally when abnormally high compressor operating temperature causes automatic shut-down of the unit. The above described shut-down is symptomatic of a clogged or dirty filter or condenser coil, thus causing a reduction in cooling air flow across the surface of the compressor and condenser coil.

HOW TO REMOVE, CLEAN OR INSTALL AN OPTIONAL INLET AIR FILTER

Aluminum washable air filters are designed to provide excellent filtering efficiency with a high dust holding capacity and a minimum amount of resistance to air flow. Because they are constructed entirely of aluminum they are lightweight and easy to service. To achieve maximum performance from your air handling equipment, air filters should be cleaned on a regular basis.

The inlet air filter is located behind the front louvered grille. To access the filter, pull the filter up and out of retaining tabs in the bottom of the front louvered grille. The filter may now be cleaned or a new filter installed.

Cleaning Instructions:

1. Flush the filter with warm water from the exhaust side to the intake side. **DO NOT USE CAUSTICS.**
2. After flushing, allow filter to drain. Placing it with a corner down will assure complete drainage.

CONDENSER AND EVAPORATOR AIR MOVERS

Impeller motors require no maintenance. All bearings, shafts, etc. are lubricated during manufacturing for the life of the motor.

If one of the condenser impeller motors (ambient impellers) should fail, it is not necessary to remove the air conditioner from the cabinet or enclosure to replace the blower. The condenser blower is mounted on its own bracket and is easily accessible by removing the louvered grille.



CAUTION

Operation of the air conditioner in areas containing airborne caustics or chemicals can rapidly deteriorate filters, condenser coils, blowers and motors, etc. Contact Pentair Equipment Protection for special recommendations.

MAINTENANCE / INSPECTION RECOMMENDATIONS
(Perform on a biannual basis - more frequently as required by the operating environment)

Status ✓ or x	Check Point	Description
	Operational Inspection	Run unit through all modes of operations and record temperatures, voltages, amperes.
	Visual Inspection	Visually inspect unit for damage, cleanliness, missing, loose and/or broken parts.
	Filter Maintenance	Inspect, clean and replace filter as necessary.
	Clean Unit	Inspect and clean coils, fans/blowers, louvers, air inlets/outlets, interior and exterior of unit as required.
	Controller Cycle Sequence	Cycle the controller through all modes of operation to ensure proper cycling and temperature setpoint operation. Adjust to proper setting (typically 25°C-30°C).
	Air Flow and Circulation	Inspect air conditioning unit, cabinet and surrounding area to ensure adequate airflow to and from the unit on both the inlet and outlet air channels for the ambient air and cabinet air.
	Seals, Gaskets and Leaks	Inspect and repair the seals, gaskets and access holes around the unit and/or cabinet that show signs of leaking air and/or moisture.
	Condensate and Drains	Inspect and clean the condensate pans and drains to ensure proper drainage and dissipation of moisture.
	Electrical/Wiring	Inspect for loose, damaged, corroded or chaffing wiring and connections. Tighten, insulate or tie-up wires as required.
	Options and Accessories	Check operation and functionality of optional and accessory items such as digital display/controller, door switches, alarm switches, air baffles/deflectors, etc.
	Refrigeration System	Inspect refrigeration tubing/lines for signs of leaks, rubbing, corrosion or damage. Check the compressor for proper operation, mounting and visible signs of exposure to high heat.
	Maintenance Records	Update maintenance records on the unit and in the management system.

BASIC AIR CONDITIONING TROUBLE SHOOTING CHECK LIST - REMOTE ACCESS CONTROL VERSION

1. Check manufacturer's nameplate located on the unit for correct power supply.
2. Turn on power to the unit. The controller will display a start up sequence then revert to the normal temperature display mode. Is the correct enclosure temperature displayed?

Note: The temperature may be alternating with an alarm code.

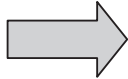
YES, proceed to step 3.		
NO, possible problem:		
<ul style="list-style-type: none"> » Open controller fuse » Controller in alarm condition. See Alarm Condition Display on page 15. » Defective controller » Defective thermistor - check by blowing warm air across the thermistor. If display temperature rises, thermistor is operable. 		<div style="background-color: black; color: white; padding: 5px; display: inline-block;">Replace part</div>

3. The cooling status indication (symbol G) should be on. Is the symbol on? If not, press and hold the lower right snowflake button for greater than five seconds. Is the cooling mode symbol now on?

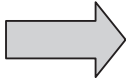
YES, proceed to step 4.		
NO, possible problem:		
<ul style="list-style-type: none"> » Defective controller 		<div style="background-color: black; color: white; padding: 5px; display: inline-block;">Replace part</div>

4. The evaporator (Enclosure or COLD air) fan/impeller should turn on. Is there airflow?

YES, proceed to step 5.		
NO, possible problem:		
<ul style="list-style-type: none"> » Controller in alarm condition. See Alarm Condition Display on page 15. » Open motor winding » Stuck fan/impeller » Obstructed blades/wheel » Defective motor capacitor 		<div style="background-color: black; color: white; padding: 5px; display: inline-block;">Repair or Replace defective part</div>

5. Start the cooling cycle by changing the cooling setpoint parameter (r01) to the low limit of 20°C. Symbol 1 should be displayed indicating a call for cooling. If symbol 1 is flashing, the unit is in Restart Time Delay mode. Within 6 minutes, symbol 1 should display without flashing. Is symbol 1 displayed without flashing?

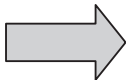
YES, proceed to step 7.		
NO, possible problem:		
<ul style="list-style-type: none"> » Unit still in Recycle Time Delay mode » Enclosure temperature below cooling setpoint temperature 		<div style="background-color: black; color: white; padding: 5px; display: inline-block;">Wait and/or heat enclosure thermistor T1</div>

6. The compressor and the condenser (Ambient or HOT air) impeller(s) should turn on. Is there adequate airflow?

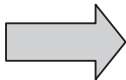
YES, proceed to step 8.		
NO, possible problem:		
<ul style="list-style-type: none"> » Open motor winding(s) » Stuck impeller(s) » Obstructed wheel(s) » Defective motor capacitor(s) 		<div style="background-color: black; color: white; padding: 5px; display: inline-block;">Repair or Replace defective part</div>

7. Carefully check the compressor for proper operation - motor should cause slight vibration and the outer case of the compressor should be warm. Is the compressor showing signs of this?

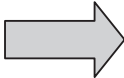
YES, wait 5 minutes, proceed to step 9.	
NO, possible problem: » Defective start or run capacitor » Defective overload » Defective start relay » Defective contactor » Defective compressor	
<div style="background-color: black; color: white; padding: 5px; display: inline-block;">Repair or Replace defective part</div>	

8. Make sure the coils are clean then check the evaporator air in and air out temperatures. If the temperatures are the same:

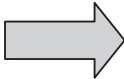
» Possible loss of refrigerant » Possible bad valves in compressor		<div style="background-color: black; color: white; padding: 5px; display: inline-block;">Repair or Replace defective part</div>
---	---	--

BASIC AIR CONDITIONING TROUBLE SHOOTING CHECKLIST

SYMPTOM	POSSIBLE CAUSE
Unit won't cool	Clogged fins on coil(s)
	Dirty filter
	Impeller(s) not running
	Compressor not running
	Compressor runs, but has bad valves
	Loss of refrigerant
Compressor tries to start but won't run	Low line voltage at start. Should be +/-10% rated voltage.
	Compressor motor stuck
	Bad contactor
	Bad overload switch
	Bad run/start capacitor
Unit blows breakers	Undersized breaker/fuse or not time delayed
	Short in system
Getting water in enclosure	Drain plugged
	Drain tube kinked
	Enclosure not sealed (allowing humidity in)
	Mounting gasket damaged

For additional support, refer to Pentair Cooling Sales and Service Contacts on page 4.

3-PHASE BASIC AIR CONDITIONING TROUBLE SHOOTING CHECK LIST - REMOTE ACCESS CONTROL VERSION

1. Check manufacturer's nameplate located on the unit for correct power supply.
2. Turn on power to the unit. The controller will display a start up sequence then revert to the normal temperature display mode. Is the correct enclosure temperature displayed?

Note: The temperature may be alternating with an alarm code.

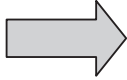
YES, proceed to step 3.		
NO, possible problem:		
<ul style="list-style-type: none"> » Open controller fuse » Controller in alarm condition. See ALARM CONDITION DISPLAY on page 60. » Defective controller » Defective thermistor - check by blowing warm air across the thermistor. If display temperature rises, thermistor is operable. 		<div style="background-color: black; color: white; padding: 5px; display: inline-block;">Replace part</div>

3. The cooling status indication (symbol G) should be on. Is the symbol on? If not, press and hold the lower right "snowflake" button for greater than five seconds. Is the cooling mode symbol now on?

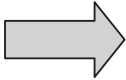
YES, proceed to step 4.		
NO, possible problem:		
<ul style="list-style-type: none"> » Defective controller 		<div style="background-color: black; color: white; padding: 5px; display: inline-block;">Replace part</div>

4. The evaporator (Enclosure or "COLD" air) fan/impeller should turn on. Is there airflow?

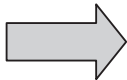
YES, proceed to step 5.		
NO, possible problem:		
<ul style="list-style-type: none"> » Controller in alarm condition. See ALARM CONDITION DISPLAY on page 60. » Open motor winding » Stuck fan/impeller » Obstructed blades/wheel » Defective motor capacitor 		<div style="background-color: black; color: white; padding: 5px; display: inline-block;">Repair or Replace defective part</div>

5. Check phase monitor indicator light, is it illuminated?

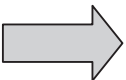
YES, proceed to step 6.		
NO, possible problem:		
<ul style="list-style-type: none"> » Incorrect electrical phasing 		<p>De-energize unit and swap any two power leads to unit. If problem still persists, replace phase monitor. Refer to phase monitor section of this manual for additional information.</p>

6. Start the cooling cycle by changing the cooling setpoint parameter (r01) to the low limit of 72 F (22 C). Symbol 1 should be displayed indicating a call for cooling. If symbol 1 is flashing, the unit is in Restart Time Delay mode. Within 6 minutes, symbol 1 should display without flashing. Is symbol 1 displayed without flashing?

YES, proceed to step 7.		
NO, possible problem:		
<ul style="list-style-type: none"> » Unit still in Recycle Time Delay mode » Enclosure temperature below cooling setpoint temperature 		<div style="background-color: black; color: white; padding: 5px; display: inline-block;">Wait and/or heat enclosure thermistor T1</div>

7. The compressor and the condenser (Ambient or “HOT” air) impeller(s) should turn on. Is there adequate airflow?

YES, proceed to step 8.
NO, possible problem: » Open motor winding(s) » Stuck impeller(s) » Obstructed wheel(s) » Defective motor capacitor(s)

**Repair or Replace
defective part**

8. Carefully check the compressor for proper operation - motor should cause slight vibration and the outer case of the compressor should be warm. Is the compressor showing signs of this?

YES, wait 5 minutes, proceed to step 9.
NO, possible problem: » Defective start or run capacitor » Defective overload » Defective start relay » Defective contactor » Defective compressor

**Repair or Replace
defective part**

9. Make sure the coils are clean then check the evaporator “air in” and “air out” temperatures. If the temperatures are the same:

» Possible loss of refrigerant » Possible bad valves in compressor

**Repair or Replace
defective part**

3-PHASE SYMPTOMS AND POSSIBLE CAUSES - REMOTE ACCESS CONTROL VERSION

SYMPTOM	POSSIBLE CAUSE
Unit won't cool	Clogged fins on coil(s)
	Dirty filter
	Impellers not running
	Compressor not running
	Compressor runs, but has bad valves
	Loss of refrigerant
Compressor tries to start but won't run	Low line voltage at start. Should be +/- 10% rated voltage.
	Compressor motor stuck
	Bad contactor
	Bad overload switch
	Bad run/start capacitor
Unit blows breakers	Undersized breaker/fuse or not time delayed
	Short in system
Getting water in enclosure	Drain plugged
	Drain tube kinked
	Enclosure not sealed (allowing humidity in)
	Mounting gasket damaged

For additional technical support, contact Pentair Equipment Protection at 800-896-2665.



Pentair Electrical
2100 Hoffman Way
Anoka, MN 55303 USA
☎ +1.763.422.2211
📠 +1.763.576.3200

PentairProtect.com