

Metallic Systems

Accessories - Enlargers



Technical Characteristics

Conforms to	Metric Threads EN60423 & BS 3643 PG Threads DIN 40430		
Approvals and Standards	N/A		
Degree of mechanical protection	High		
Degree of protection	Maintains IP rating of system when used with correct sealing washers		
UV protection	Very High		
Fitting characteristics	Thread enlarger		
Application	To enlarge thread sizes		
Normal operating temperature range	Application	Min Temp	Max Temp
	Static	- 50°C	+300°C
	Dynamic	- 45°C	+250°C
For use with - Fittings	All threaded fittings in the Adaptaflex range		
Fire performance	Test Standard	Performance Rating	
	Not Rated	Not Rated	
Testing data	N/A		
Type of material	Nickel Plated Brass		

Image



Metallic Systems

Accessories - Enlargers



Dimensional & Thread Data

Part No	Thread A	Thread B	Nominal Dimensions (mm)				
			C	D	E	F	G
B/M16-M20/E	M16x1.5	M20x1.5	9.0	12.0	26.0	12.0	22.0
B/M20-M25/E	M20x1.5	M25x1.5	9.5	11.0	25.5	15.5	27.0
B/M25-M32/E	M25x1.5	M32x1.5	9.5	12.0	24.5	19.1	34.0
B/PG9-PG11/E	PG9	PG11	8.0	7.5	18.0	12.0	20.0
B/PG9-PG13/E	PG9	PG13.5	6.0	12.0	20.0	12.0	22.0
B/PG11-PG13/E	PG11	PG13.5	7.0	12.0	20.0	15.0	22.0
B/PG11-PG16/E	PG11	PG16	6.0	12.0	19.0	15.0	ø24.0
B/PG13-PG21/E	PG13.5	PG21	6.5	11.0	21.0	16.8	30.0
B/PG16-PG21/E	PG16	PG21	6.5	11.0	21.0	18.5	30.0
B/PG21-PG29/E	PG21	PG29	7.0	12.5	23.0	24.0	42.0
B/PG29-PG36/E	PG29	PG36	8.0	15.0	27.54	32.0	50.0
B/PG36-PG48/E	PG36	PG48	12.0	12.5	27.0	42.0	ø63.5

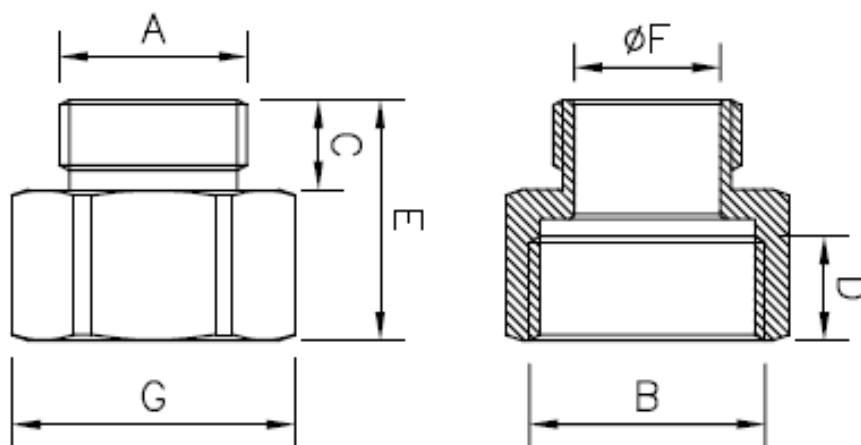

Metallic Systems

Accessories - Enlargers



Chemical Resistance Chart

Key:

Suitable :



Limited Suitability :



Unsuitable :



Not Tested :



Astm No.1	Diesel oil	Methyl Bromide	Sulphur Dioxide (Gas)
Astm No.2	Diethylamine	MEK	Sulphuric Acid (10%)
Astm No.3	Ethanol	Nitric Acid (10%)	Sulphuric Acid (70%)
Acetic Acid (10%)	Ether	Nitric Acid (70%)	Toluene
Acetone	Ethylamine	Oxalic Acid	Transformer Oil
Aluminium Chloride	Ethylene Glycol	Ozone (Gas)	1,1,1-Trichloroethane
Aniline	Ethyl Ethanoate	Paraffin oil	Trichloroethylene
Benzaldehyde	Freon 32	Petrol	Turpentine
Benzene	Hydrochloric Acid (10%)	Phenol	Vegetable Oil
Carbon tetrachloride	Hydrochloric Acid (36%)	Sea Water	Vinyl Acetate
Chlorine water	Hydrogen Peroxide (35%)	Silver Nitrate	Water
Chloroform	Hydrogen Peroxide (87%)	Skydrol	White Spirit
Citric Acid	Lactic Acid	Sodium Chloride	Zinc Chloride
Copper Sulphate	Lubricating oil	Sodium Hydroxide (10%)	
Cresol	Methanol	Sodium Hydroxide (60%)	

The information above is given as a guide only and is based on published technical data and experience. The chemical resistance of the above products is dependant on factors such as chemical exposure, concentration of the chemical and temperature. The above chemicals are valid for a temperature of 23°C. Use of the above table is at the users own discretion and risk. Those using it must satisfy themselves that their application presents no health and safety risks. The end user should assess compatibility with their application and contact Thomas & Betts for further information.

ADHERENCE TO THE CURRENT WIRING REGULATIONS BS7671 OR NEC WIRING REGULATIONS (FOR USA) IS STRONGLY ADVISED.

MINIMUM BEND RADIUS FOR FLEXING IS DEPENDANT UPON MINIMUM TEMPERATURE, BENDING FREQUENCY AND CHEMICAL ENVIRONMENT.